

R-LIFTING

QINGDAO R-LIFTING INDUSTRIES CO.,LTD

Add:3rd Space Building,10# Haifeng Road, Qingdao, China

Email: info@r-lifting.com



R-LIFTING

Company Profile

QINGDAO R-LIFTING INDUSTRIES CO.,LTD was founded in 2003, specializes in the field of rigging hardware, lifting equipment and lashing equipment, wire rope, chain, ratchet tie down, webbing sling, marine hardware, Tools & other products. With years of experience and speedy development, we now supplies a range of industrial products that cover lifting, lashing, sling, rigging, marine, mining, transportation, construction .etc

We are located in a beautiful city Qingdao, China. All products are produced under strict standard of quality control. Constant research and development ensures that you are getting the latest products produced with the most advanced and cost effective technologies.

We supervise the quality according to international standards, we thinks much of the demands of customers, putting customers' benefits at the first place and pursuing excellent sources of products for competitive price in world market. Standardization and high efficiency operating procedure insures the accurate and speedy shipment to all over the world. we are glad to make good trade companionship with you on a mutually beneficial basis and serve to your heart and soul.

Give us a small chance, big difference will be made for you.

WIRE ROPE	1 ~ 14
CHAIN	15 ~ 24
LIFTING SLING	25 ~ 44
SLEEVE	
ALUMINIUM SLEEVE	47 ~ 49
ALUMINIUM & COPPER SLEEVE	50
COPPER SLEEVE	51
STEEL SLEEVE	52 ~ 57
SWAGING MACHINE	58-61
MANUAL TOOL	
MULTI-FUNCTION SWAGING TOOL	63
BOLT CUTTER	64
LOAD BINDER	65
RIGGING HARDWARE	
SHACKLE	67 ~ 71
WIRE ROPE CLIP	72 ~ 73
TURNBUCKLE	74 ~ 75
THIMBLE	76 ~ 77
EYE BOLT & EYE NUT	78 ~ 80
HOOK	81 ~ 86
RING	87 ~ 90
SNAP HOOK	91
QUICK LINK	92
DIE CASTING PRODUCT	93
STAINLESS STEEL PRODUCT	94 ~ 97
G80 FITTING	98 ~ 104
LIFTING EQUIPMENT	105 ~ 144
PE&PP ROPE	145 ~ 158
ANCHOR & ANCHOR CHAIN	
ANCHOR CHAIN	160 ~ 165
ANCHOR	166 ~ 170

WIRE ROPE

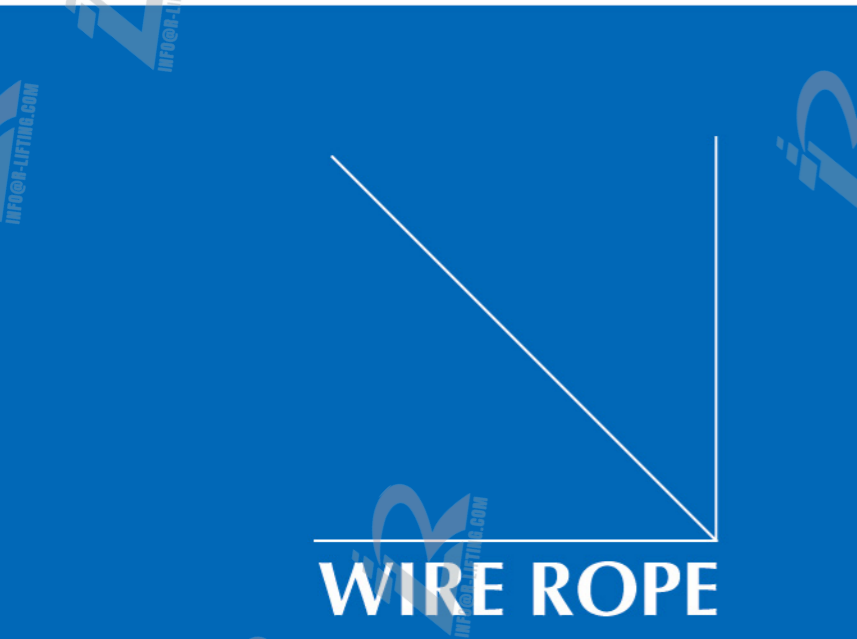

GENERAL INFORMATION ON WIRE ROPES

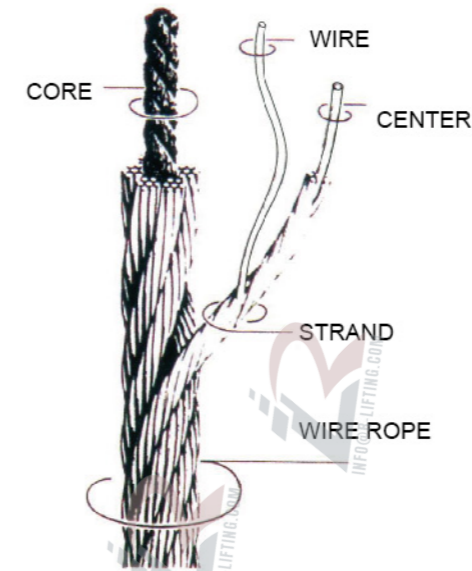

What is a wire rope? It consists of a group of strands laid helically around a core. In some cases, a single strand is a rope.

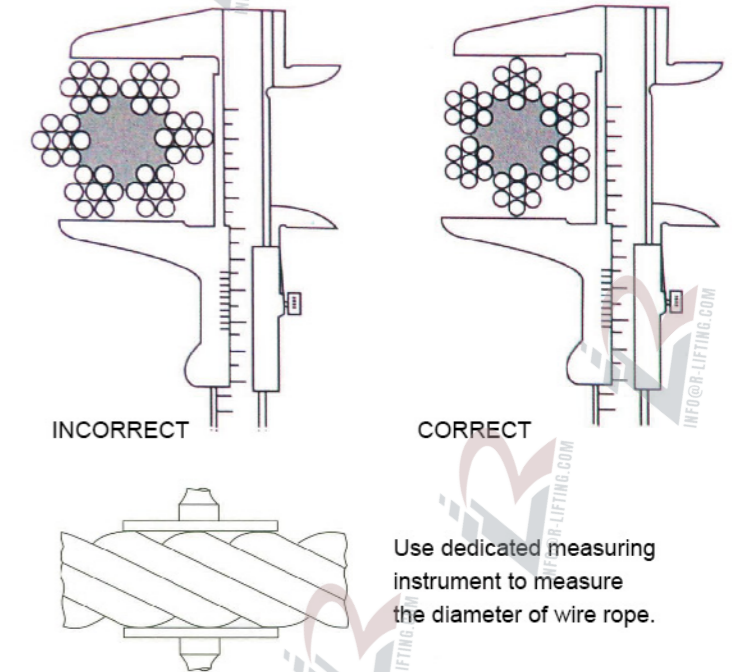

TYPE AND DIRECTION OF LAY



Main type of wire rope	Typical structure
Point contact round strand wire rope	6×19 6×37 6×24
Linear contact round strand wire rope	6×19S 6×19W 6×25Fi 6×29Fi 6×26WS 6×31WS 6×36WS 6×37S
Triangular strand wire rope	6V19 6V30 6V34 6V37 6V37S
Compacted strand wire rope	6×K25Fi 6×K19S 6×K36WS 8×K26WS 8×K31WS 18×K7 18×K19S 35(W)×K7 40(W)×K7
Wire rope with PVC	

WIRE ROPE

Typical Cross Sections Of Wire Rope & Strand

6x7+FC	6x7+IWS	6x9W+FC	6x9W+IWR	6x19S+FC	6x19S+IWR	6x19W+FC
6x19W+IWR	6x19+FC	6x19+IWS	6x41SW+FC	6x41SW+IWR	6x49SWS+FC	6x49SWS+IWR
6x55SWS+FC	6x55SWS+IWR	6x25Fi+FC	6x25Fi+IWR	6x26SW+FC	6x26SW+IWR	6x29Fi+FC
6x29Fi+IWR	6x31SW+FC	6x31SW+IWR	6x36SW+FC	6x36SW+IWR	6x37S+FC	6x37S+IWR
6x37+FC	6x37+IWR	8x19S+FC	8x19S+IWR	8x19W+FC	8x19W+IWR	8x25Fi+FC
8x25Fi+IWR	8x25SW+FC	8x26SW+IWR	8x31SW+FC	8x31SW+IWR	8x36SW+FC	8x36SW+IWR

WIRE ROPE

Typical Cross Sections Of Wire Rope & Strand

8x41SW+FC	8x41SW+IWR	8x49SWS+FC	8x49SWS+IWR	8x55SWS+FC	8x55SWS+IWR	17x7+FC
17x7+IWS	18x7+FC	18x7+IWS	18x19W+FC	18x19W+IWS	18x19S+FC	18x19S+IWS
18x19+FC	18x19+IWS	34x7+FC	34x7+IWS	36x7+FC	36x7+IWS	6x24+7FC
6x24S+7FC	6x24W+7FC	6Vx18+FC	6Vx18+IWR	6Vx21+7FC	6Vx30+FC	6Vx30+IWR
6Vx33+FC	6Vx33+IWR	6Vx36+FC	6Vx36+IWR	6Vx43+FC	6Vx43+IWR	6Vx37S+FC
6Vx37S+IWR	4Vx39S+5FC	4Vx48S+5FC	1x7	1x19	3x7	6x3+IWS

WIRE ROPE

Aircraft Cord

Construction: 6×7+FC,6×7+IWS

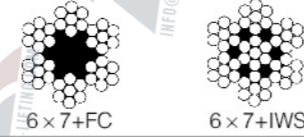

Diameter (mm)		Nominal Tensile Strength of Wire (Mpa)	Fibre Core-The Minimum Breaking Load of Rope (KN)	Steel Core-The Minimum Breaking Load of Rope (KN)	Fibre Core Approx. Weight of Rope (kg/100m)	Steel Core Approx. Weight of Rope (kg/100m)
Rope	Wire					
1.58	0.17	1870	1.57	1.83	1.01	1.09
1.70	0.19	1870	1.95	2.23	1.26	1.37
1.80	0.20	1870	2.28	2.50	1.40	1.50
2.15	0.24	1870	3.28	3.60	2.00	2.20
2.50	0.28	1870	4.47	5.00	2.70	3.00
3.50	0.34	1870	6.23	7.32	4.00	4.40
3.60	0.40	1870	8.7	10.10	5.50	6.20
4.10	0.45	1770	10.4	13.20	7.00	7.95
4.50	0.50	1770	12.8	15.00	8.70	9.60
5.40	0.60	1670	17.5	20.40	12.50	13.80

Main Applications: Suitable for important machinery and instrument.

Aircraft Cord

Construction: 6×19+FC,6×19+IWS

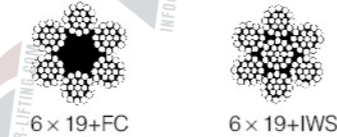

Diameter (mm)		Nominal Tensile Strength of Wire (Mpa)	Fibre Core-The Minimum Breaking Load of Rope (KN)	Steel Core-The Minimum Breaking Load of Rope (KN)	Fibre Core Approx. Weight of Rope (kg/100m)	Steel Core Approx. Weight of Rope (kg/100m)
Rope	Wire					
3.00	0.20	2062	6.3	7.3	3.80	4.20
3.30	0.22	1770	6.5	7.59	4.50	5.74
3.60	0.24	1770	7.8	9.1	5.40	6.00
4.20	0.28	1770	10.6	12.3	7.40	8.20
4.80	0.31	1770	12.9	16	9.00	10.71
5.10	0.34	1770	15.6	18.1	10.90	12.00
6.00	0.40	1670	19	23.7	15.10	16.70
6.30	0.42	1670	22.2	26.1	16.65	18.41
7.50	0.50	1670	31.9	37.1	23.59	26.00
8.25	0.55	1670	38.4	44.9	28.55	32.00
9.00	0.60	1670	45.7	53.4	33.98	37.60
9.75	0.65	1670	50.3	62.6	39.88	44.10

Main Applications: Suitable for important machinery and instrument.

WIRE ROPE

Steel Wire Rope(Ungalvanized and Galvanized)

Construction: 6 × 24+7FC



Nominal Diameter (D/mm)	Approx. Weight (kg/100m)		Nominal Tensile Strength of Rope				
			1470	1570	1670	1770	1870
	NF	SF	Minimum Breaking Load of Rope				
8	20.4	19.5	26.3	28.1	29.9	31.7	33.5
9	25.8	24.6	33.3	35.6	37.9	40.1	42.4
10	31.8	30.4	41.2	44	46.8	49.6	52.4
11	38.5	36.8	49.8	53.2	56.6	60	63.4
12	45.8	43.8	59.3	63.3	67.3	71.4	75.3
13	53.7	51.4	69.6	74.3	79	83.8	88.5
14	62.3	59.6	80.7	86.2	91.6	97.1	103
16	81.4	77.8	105	113	120	127	134
18	103	98.5	133	142	152	161	170
20	127	122	165	176	187	198	209
22	154	147	199	213	226	240	253
24	183	175	237	253	269	285	302
26	215	206	278	297	316	335	354
28	249	238	323	345	367	389	411
30	286	274	370	396	421	446	471
32	326	311	421	450	479	507	536
34	368	351	476	508	541	573	605
36	412	394	533	570	606	642	679
38	459	439	594	635	675	716	756
40	509	486	659	703	748	793	838
42	561	536	726	775	825	874	924
44	616	589	797	851	905	959	1010
46	673	643	871	930	989	1050	1110
48	733	700	948	1010	1080	1140	1210
50	795	760	1030	1100	1170	1240	1310
52	860	822	1110	1190	1260	1340	1420
54	927	886	1200	1280	1360	1450	1530
56	997	953	1290	1380	1470	1550	1640
58	1070	1020	1380	1480	1570	1670	1760
60	1140	1090	1480	1580	1680	1780	1880
62	1220	1170	1580	1690	1800	1910	2010
64	1300	1250	1690	1800	1920	2030	2140
66	1390	1320	1790	1910	2040	2160	2280
68	1470	1410	1900	2030	2160	2290	2420
70	1560	1490	2020	2150	2290	2430	2570
72	1650	1580	2130	2280	2420	2570	2710
74	1740	1660	2250	2410	2560	2710	2870
76	1840	1760	2380	2540	2700	2860	3020
78	1930	1850	2500	2670	2840	3020	3190
80	2040	1950	2630	2810	2990	3170	3350

Main Applications: Towboat, goods net, floating transportation of wood, bunding etc.

WIRE ROPE

NO-rotating Steel Wire Rope With Many Layers (Ungalvanized and Galvanized)

Construction: 35W x 7

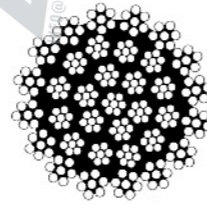

35W x 7

Nominal Diameter (mm)	Approx.Weight (kg/100m)	Nominal Tensile Strength of Rope (MPa)					
		1570	1670	1770	1870	1960	2160
		Minimun Breaking Load of Rope (KN)					
6	16.6	20.3	21.6	22.9	24.2	25.4	28
8	29.4	36.2	38.5	40.8	43.1	45.2	49.8
10	46	56.5	60.1	63.7	67.3	70.6	77.8
12	66.2	81.4	86.6	91.8	96.9	102	112
14	90.2	111	118	125	132	138	152
16	118	145	154	163	172	181	199
18	149	183	195	206	218	229	252
20	184	226	240	255	269	282	311
22	223	274	291	308	326	342	376
24	265	326	346	367	388	406	448
26	311	382	406	431	455	477	526
28	361	443	471	500	528	553	610
30	414	509	541	573	606	635	700
32	471	579	616	652	689	723	796
34	532	653	695	737	778	816	899
36	596	732	779	826	872	914	1010
38	664	816	868	920	972	1020	1120
40	736	904	962	1020	1080	1130	1240
42	811	997	1060	1120	1190	1240	1370
44	891	1090	1160	1230	1300	1370	1510
46	973	1200	1270	1350	1420	1490	1650
48	1060	1300	1390	1470	1550	1630	1790
50	1150	1410	1500	1590	1680	1760	1940
52	1240	1530	1630	1720	1820	1910	2100
54	1340	1650	1750	1860	1960	2060	2270
56	1440	1770	1890	2000	2110	2210	2440
58	1550	1900	2020	2140	2260	2370	2620
60	1660	2030	2160	2290	2420	2540	2800

Main Applications: Equipment for port load and unload derrick tower crane.

Steel Wire Rope(Ungalvanized and Galvanized)

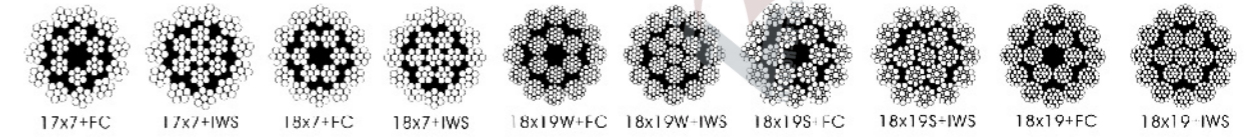

Nominal Diameter (D/mm)	Approx.Weight (kg/100m)		Nominal Tensile Strength of Rope (MPa)											
			1570	1670	1770	1870	1960	2160						
	FC	IWR/IWS	Minimun Breaking Load of Rope (KN)											
6	14	15.5	17.5	18.5	18.6	19.7	19.8	20.9	20.9	22.1	21.9	23.1	24.1	25.5
7	19.1	21.1	23.8	25.2	25.4	26.8	26.9	28.4	28.4	30.1	29.8	31.5	32.8	34.7
8	25	27.5	31.1	33	33.1	35.1	35.1	37.2	37.1	39.3	38.9	41.1	42.9	45.3
9	31.6	34.8	39.4	41.7	41.9	44.4	44.4	47	47	49.7	49.2	52.1	54.2	57.4
10	39	43	48.7	51.5	51.8	54.8	54.9	58.1	58	61.3	60.8	64.3	67	70.8
11	47.2	52	58.9	62.3	62.6	66.3	66.4	70.2	70.1	74.2	73.5	77.8	81	85.7
12	56.2	61.9	70.1	74.2	74.5	78.9	79	83.6	83.5	88.3	87.5	92.6	96.4	102
13	65.9	72.7	82.3	87	87.5	92.6	92.7	98.1	98	104	103	109	113	120
14	76.4	84.3	95.4	101	101	107	108	114	114	120	119	126	131	139
16	99.8	110	125	132	133	140	140	149	148	157	156	165	171	181
18	126	139	158	167	168	177	178	188	188	199	197	208	217	230
20	156	172	195	206	207	219	219	232	232	245	243	257	268	283
22	189	208	236	249	251	265	266	281	281	297	294	311	324	343
24	225	248	280	297	298	316	316	334	334	353	350	370	386	408
26	264	291	329	348	350	370	371	392	392	415	411	435	453	479
28	306	337	382	404	406	429	430	455	454	481	476	504	525	555
30	351	387	438	463	466	493	494	523	522	552	547	579	603	638
32	399	440	498	527	530	561	562	594	594	628	622	658	686	725
34	451	497	563	595	598	633	634	671	670	709	702	743	774	819
36	505	557	631	667	671	710	711	752	751	795	787	833	868	918
38	563	621	703	744	748	791	792	838	837	886	877	928	967	1020
40	624	688	779	824	828	876	878	929	928	981	972	1030	1070	1130
42	688	759	859	908	913	966	968	1020	1020	1080	1070	1130	1180	1250
44	755	832	942	997	1000	1060	1060	1120	1120	1190	1180	1240	1300	1370
46	825	910	1030	1090	1100	1160	1160	1230	1230	1300	1290	1360	1420	1500
48	899	991	1120	1190	1190	1260	1260	1340	1340	1410	1400	1480	1540	1630
50	975	1080	1220	1290	1290	1370	1370	1450	1450	1530	1520	1610	1670	1770
52	1050	1160	1320	1390	1400	1480	1480	1570	1570	1660	1640	1740	1810	1920
54	1140	1250	1420	1500	1510	1600	1600	1690	1690	1790	1770	1870	1950	2070
56	1220	1350	1530	1610	1620	1720	1720	1820	1820	1920	1910	2020	2100	2220
58	1310	1450	1640	1730	1740	1840	1850	1950	1950	2060	2040	2160	2250	2380
60	1400	1550	1750	1850	1860	1970	1980	2090	2090	2210	2190	2310	2410	2550

Main Applications: Equipment for port load and unload derrick tower crane.



CHAIN

CHAIN

ASTM1980 Standard Link Chain



I .Proof Coil Chain ASTM1980 (G30)

Size inch	Material Diameter		Working Load Limit		Proof Test		Breaking Force Minimum		Max Length Per 100 Links		Max Weight Per 100 Feet	
	inch	mm	lbs	kg	lbs	kn	lbs	kn	inch	m	lbs	kg
1/8	0.156	4	375	170	800	3.6	1600	7.1	94	2.39	19	8.8
3/16	0.218	5.5	750	340	1500	6.7	3000	13.3	99	2.51	42	19
1/4	0.281	7.1	1250	570	2500	11.1	5000	22.2	104	2.64	76	34
5/16	0.343	8.7	1900	860	3800	16.9	7600	33.8	114	2.89	115	52
3/8	0.406	10.3	2650	1200	5300	23.6	10600	47.2	128	3.25	166	75
7/16	0.468	11.9	3500	1590	7000	31.1	14000	62.3	142	3.60	225	102
1/2	0.531	13.5	4500	2040	9000	40.0	18000	80.1	156	3.96	289	131
5/8	0.656	16.7	6900	3130	13800	61.4	27600	122.8	194	4.92	425	193
3/4	0.781	19.8	9750	4420	19500	86.7	39000	173.5	220	5.59	612	278



II .High Test Chain ASTM1980 (G43)

Size inch	Material Diameter		Working Load Limit		Proof Test		Breaking Force Minimum		Max Length Per 100 Links		Max Weight Per 100 Feet	
	inch	mm	lbs	kg	lbs	kn	lbs	kn	inch	m	lbs	kg
1/4	0.281	7.1	2600	1180	4300	19.1	7750	34.5	98	2.49	84	38
5/16	0.343	8.7	3900	1770	6400	28.5	11600	51.6	110	2.79	120	54
3/8	0.406	10.3	5400	2450	8900	39.6	16200	72.1	134	3.4	176	80
7/16	0.468	11.9	7200	3260	11900	52.9	21500	95.6	140	3.55	230	104
1/2	0.531	13.5	9200	4170	15300	68.1	27600	122.8	150	4.06	300	136
5/8	0.656	16.7	14200	6200	21200	94	42400	188	194	4.92	425	193



III .Transport Chain ASTM1980 (G70)

Size inch	Material Diameter		Working Load Limit		Proof Test		Breaking Force Minimum		Max Length Per 100 Links		Max Weight Per 100 Feet	
	inch	mm	lbs	kg	lbs	kn	lbs	kn	inch	m	lbs	kg
1/4	0.281	7.1	3150	1430	6300	28.0	12600	56.1	98	2.49	84	38
5/16	0.343	8.7	4700	2130	9400	41.8	18800	83.6	110	2.79	120	54
3/8	0.406	10.3	6600	3000	13200	58.7	26400	117.4	134	3.40	176	80
1/2	0.531	13.5	11300	5130	22600	100.5	45200	201.1	160	4.06	300	136

CHAIN

NACM1990 Standard Link Chain

I .Proof Coil Chain NACM1990 (G30)



Size		Material Diameter		Working Load Limit (Max)		Proof Test(Min)		Breaking Force (Min)		Inside Length (Max)		Inside Width (Min)	
mm	inch	mm	inch	kg	lbs	kn	lbs	kn	lbs	mm	inch	mm	inch
4	1/8	4	0.156	170	375	3.6	800	7.1	1600	23.9	0.94	6.4	0.25
5.5	3/16	5.5	0.217	365	800	7.2	1600	14.3	3200	24.8	0.98	7.7	0.3
7	1/4	7	0.276	580	1300	11.6	2600	23.1	5200	31.5	1.24	9.8	0.38
8	5/16	8	0.315	860	1900	15.1	3400	30.2	6800	32.8	1.29	11.2	0.44
10	3/8	10	0.394	1200	2650	23.6	5300	47.1	10600	35	1.38	14	0.55
13	1/2	13	0.512	2030	4500	39.8	8950	79.6	17900	45.5	1.79	18.2	0.72
16	5/8	16	0.63	3130	6900	60.3	13600	120.6	27200	56	2.2	20	0.79
20	3/4	20	0.787	4800	10600	94.3	21200	188.5	42400	70	2.76	25	0.98
22	7/8	22	0.866	5810	12800	114.1	25600	228.1	51200	77	3.03	27.5	1.08
25	1"	26	1.02	8140	17900	159.1	35800	318.2	71600	90.9	3.58	31.7	1.25



II .High Test Chain NACM1990 (G43)

Size		Material Diameter		Working Load Limit (Max)		Proof Test(Min)		Breaking Force (Min)		Inside Length (Max)		Inside Width (Min)	
mm	inch	mm	inch	kg	lbs	kn	lbs	kn	lbs	mm	inch	mm	inch
7	1/4	7	0.276	1180	2600	16.6	3750	33.1	7500	31.5	1.24	9.8	0.38
8	5/16	8	0.315	1770	3900	21.6	4900	43.2	9700	32.8	1.29	11.2	0.44
10	3/8	10	0.394	2450	5400	33.8	7600	67.6	15200	35	1.38	14	0.55
13	1/2	13	0.512	4170	9200	57.1	12900	114.2	25700	45.5	1.79	18.2	0.72
16	5/8	16	0.63	5220	11500	86.5	19500	172.9	38900	56	2.2	20	0.79
20	3/4	20	0.787	7350	16200	130.1	30400	270.2	60700	70	2.76	25	0.98



III .Transport Chain NACM1990 (G70)

Size		Material Diameter		Working Load Limit (Max)		Proof Test(Min)		Breaking Force (Min)		Inside Length (Max)		Inside Width (Min)	
mm	inch	mm	inch	kg	lbs	kn	lbs	kn	lbs	mm	inch	mm	inch
7	1/4	7	0.276	1430	3150	27	6100	53.9	12100	31.5	1.24	9.8	0.38
8.7	5/16	8.7	0.343	2130	4700	41.6	9400	83.5	18800	33.5	1.32	12.2	0.48
10	3/8	10	0.394	2990	6600	55	12400	110	24700	35	1.38	14	0.55
11.9	7/16	11.9	0.468	3970	8750	77.7	17500	155.4	35000	41.6	1.64	16.6	0.65
13	1/2	13	0.512	5130	11300	92.9	20900	185.8	41800	45.5	1.79	18.2	0.72
16	5/8	16	0.63	7170	15800	140.4	31600	280.8	63200	56	2.2	20	0.79
20	3/4	20	0.787	11200	24700	49.9	49500	439.8	98900	70	2.76	25	0.98

CHAIN

NACM1996/2003 Standard Link Chain

I .Proof Coil Chain NACM1996/2003 (G30)



Size		Material Diameter		Working Load Limit (Max)		Proof Test(Min)		Breaking Force (Min)		Inside Length (Max)		Inside Width (Min)	
mm	inch	mm	inch	kg	lbs	kn	lbs	kn	lbs	mm	inch	mm	inch
4	1/8	4	0.156	180	400	3.6	800	7.2	1600	23.9	0.94	6.4	0.25
5.5	3/16	5.5	0.217	365	800	7.2	1500	14.4	3200	24.8	0.98	7.7	0.3
7	1/4	7	0.276	580	1300	11.6	2600	23.2	5200	31.5	1.24	9.8	0.38
8.4	5/16	8	0.331	860	1900	16.9	3800	33.8	7600	32.8	1.29	11.2	0.44
10	3/8	10	0.394	1200	2650	23.5	5300	47.2	10600	35	1.38	14	0.55
11.9	7/16	11.9	0.488	1680	3700	32.9	7400	65.8	14800	41.5	1.64	16.6	0.65
13	1/2	13	0.512	2030	4500	40	9000	80	18000	45.6	1.79	18.2	0.72
16	5/8	16	0.63	3130	6900	61.3	13800	122.8	27600	56	2.2	20	0.79
20	3/4	20	0.787	4800	10500	94.3	21200	188.6	42400	70	2.76	25	0.98
22	7/8	22	0.865	5810	12800	114.1	25600	228.2	51200	77	3.03	27.5	1.08
25	1	26	1.02	8140	17900	159.1	35800	318.2	71600	90.9	3.58	31.7	1.25



II .High Test Chain NACM1996/2003 (G43)

Size		Material Diameter		Working Load Limit (Max)		Proof Test(Min)		Breaking Force (Min)		Inside Length (Max)		Inside Width (Min)	
mm	inch	mm	inch	kg	lbs	kn	lbs	kn	lbs	mm	inch	mm	inch
7	1/4	7	0.276	1180	2800	17.3	3900	34.6	7800	31.5	1.24	9.8	0.38
8.7	5/16	8.7	0.343	1770	3900	26	5850	52	11700	32.8	1.29	11.2	0.44
10	3/8	10.3	0.406	2450	5400	36	8100	72	16200	35	1.38	14	0.55
11.9	7/16	11.9	0.468	3270	7200	48	10800	96	21600	41.6	1.64	16.6	0.65
13	1/2	13.5	0.531	4170	9200	61.3	13800	122.6	27600	45.5	1.79	18.2	0.72
16	5/8	16	0.63	5910	13000	86.5	19500	173	39000	56	2.2	20	0.79
20	3/4	20	0.787	9180	20200	134.7	30300	269.4	60600	70	2.76	25	0.98
22	7/8	22	0.866	11140	24500	163.3	36750	326.4	73500	77	3.03	27.5	1.08



III .Transport Chain NACM1996/2003 (G70)

Size		Material Diameter		Working Load Limit (Max)		Proof Test(Min)		Breaking Force (Min)		Inside Length (Max)		Inside Width (Min)	
mm	inch	mm	inch	kg	lbs	kn	lbs	kn	lbs	mm	inch	mm	inch
7	1/4	7	0.281	1430	3150	28	6300	56	12600	31.8	1.24	9.8	0.38
8.7	5/16	8.7	0.343	2130	4700	41.8	9400	83.6	18800	32.8	1.29	11.2	0.44
11.9	3/8	10.3	0.406	2990	6600	58.7	13200	117.4	26400	35	1.38	14	0.55
13	1/2	13.5	0.531	5130	11300	100.4	22600	200.8	45200	45.5	1.79	18.2	0.72
16	5/8	16	0.63	7170	15800	140.4	31600	280.8	63200	56	2.2	20	0.79
20	3/4	20	0.787	11200	24700	219.6	49400	439.2	98800	70	2.76	25	0.98

CHAIN

NACM1990 Machine Chain/Coil Chain

I .NACM1990 Machine Chain Straight Link



Size		Material Diameter		Working Load (Max)		Proof Test (Min)		Breaking Force (Min)		Nominal Inside Length		Nominal Inside Width	
mm	inch	mm	inch	kg	lbs	kn	lbs	kn	lbs	mm	inch	mm	inch
3	4	3	0.12	98	215	1.91	430	3.82	860	14	0.55	5.3	0.21
3.4	3	3.4	0.135	122	270	2.4	540	4.8	1080	15	0.59	6.1	0.24
3.8	2	3.8	0.148	147	325	2.89	650	5.78	1300	15.5	0.61	6.6	0.26
4.1	1	4.1	0.162	177	390	3.47	780	6.93	1560	16	0.63	7.1	0.28
4.5	1/0	4.5	0.177	211	465	4.14	930	8.27	1860	18.8	0.74	7.9	0.31
4.9	2/0	4.9	0.192	247	545	4.85	1090	9.69	2180	19.8	0.78	8.6	0.34
5.3	3/0	5.3	0.207	288	635	5.65	1270	11.29	2540	21.6	0.85	9.1	0.36
5.5	4/0	5.5	0.218	318	700	6.23	1400	12.44	2800	25.1	0.99	9.6	0.38
6.4	5/0	6.4	0.25	420	925	8.23	1850	16.44	3700	27.2	1.07	11.2	0.44



II .NACM90 Machine Chain Twist Link

Size		Material Diameter		Working Load (Max)		Breaking Force (Min)		Nominal Inside Length		Nominal Inside Width	
mm	inch	mm	inch	kg	lbs	kn	lbs	mm	inch	mm	inch
3	4	3.0	0.12	93	205	3.64	820	13.1	0.52	4.3	0.17
3.4	3	3.4	0.135	116	255	4.53	1020	14.2	0.56	5.1	0.2
3.8	2	3.8	0.148	141	310	5.51	1240	14.7	0.58	5.3	0.21
4.1	1	4.1	0.162	168	370	6.58	1480	15	0.59	6.1	0.24
4.5	1/0	4.5	0.177	200	440	7.82	1760	17.2	0.68	6.6	0.26
4.9	2/0	4.9	0.192	236	520	9.24	2080	18.5	0.73	7.1	0.28
5.3	3/0	5.3	0.207	274	605	10.76	2420	20.3	0.8	7.9	0.31
5.5	4/0	5.5	0.218	304	670	11.91	2680	22.5	0.89	8.1	0.32
6.4	5/0	6.4	0.25	400	880	15.64	3520	25.3	1	9.4	0.37

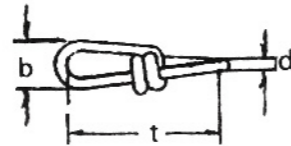

USA Standard Double Loop Chain

Item No.	Diameter		Inside Length	Outside Width	Weight Per 100ft
	d(mm)	(t)mm			
5	1.6	23.4	7	1.8	
4	1.8	24.4	8	2.2	
4L	1.8	30.5	8	1.96	
3	2	28	9	3	
3Z	2	36.3	9	2.6	
3L	2	38	10.5	2.6	
2	2.3	34	10	3.5	
1	2.7	39.5	12	4.5	
1Z	2.7	49	13.5	4.2	

Item No.	Diameter		Inside Length	Outside Width	Weight Per 100ft
	d(mm)	(t)mm			
1L	2.7	52	12	4.2	
1/0	3	45.5	14	5.7	
1/0L	3	56	14	5.2	
2/0	3.4	46.5	15.5	7.5	
2/0Z	3.4	53	15.5	7	
2/0L	3.4	57	15.5	7	
3/0	3.8	55.5	17	9.4	
4/0	4.1	56	19	11	
6/0	4.9	74	21	15.7	

CHAIN

Grade 80 Alloy Chain

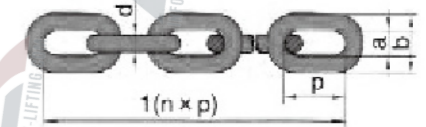

Size d x p mm	Width		Approx Weight kg/m	Working Load Limit t	Test Load kN	Breaking Load min. kN
	Inside min. a	Outside max. b				
6 x 18	7.5	21	0.79	1.1	27	45.2
7 x 21	9	24.5	1.07	1.5	37	61.6
8 x 24	10	28	1.38	2	48	80.4
10 x 30	12.5	35	2.2	3.2	76	125
11 x 43	12.6	36.5	2.33	3.8	92	154
12 x 36	15	42	3.1	4.6	109	181
12.5 x 38	15.5	42.2	3.3	4.9	117	196
13 x 39	16.3	46	3.8	5	128	214
14 x 42	18	49	4.13	6.3	150	250
14 x 50	17	48	4	6.3	150	250
15 x 46	20	52	5.17	7	168	280
16 x 48	20	56	5.63	8	192	320
16 x 49	24.5	59.5	5.71	8	192	320
16 x 64	23.9	58.9	5.11	8	192	320
18 x 54	23	63	6.85	10	246	410
18 x 64	21	60	6.6	10	246	410
19 x 57	23.7	63.2	7.7	11.3	270	450
20 x 60	25	70	8.6	12.5	300	500
22 x 65	28	74.2	10.7	15.3	366	610
22 x 66	28	77	10.2	15.3	366	610
22 x 86	26	74	9.5	15.3	366	610
24 x 72	32	82	12.78	18	432	720
24 x 86	28	79	11.6	18	432	720
26 x 78	35	91	14.87	21.3	510	850
26 x 92	30	86	13.7	21.3	510	850
30 x 90	38	105	19.6	28.3	678	1130
30 x 108	34	98	18	28.3	678	1130
32 x 96	40	106	22.29	32.2	772	1286
34 x 126	38	109	22.7	36.3	870	1450
34 x 102	46.5	121.5	25.5	36.3	870	1450
36 x 108	49.5	128.5	31	40.7	978	1630
38 x 137	42	121	29	45.3	1086	1810
38 x 114	52	136	32	45.3	1086	1810
42 x 126	55.5	144.5	38.6	55.4	1332	2200

CHAIN

Grade 100 Lifting Chain

Size d x p mm	Width		Approx Weight kg/m	Working Load Limit t		Test Load t	Breaking Load min. t
	Inside min. a	Outside max. b		G80	G100		
6 x 18	7.5	21	0.79	1.1	1.4	2.75	5.6
7 x 21	9	24.5	1.07	1.5	2	3.75	8
8 x 24	10	28	1.38	2	2.5	6.25	10
10 x 30	12.5	35	2.2	3.2	4	10	16
13 x 39	16.3	46	3.8	5	6.7	16.75	26.8
16 x 48	20	56	5.63	8	10	25	40
19 x 57	23.7	63.2	7.7	11.3	14	35	56
20 x 60	25	70	8.6	12.5	15.6	39	62.4
22 x 66	28	77	10.2	15.3	19.1	47.75	76.4
26 x 78	35	91	14.87	21.3	27	67.5	108
32 x 96	40	106	22.29	32.2	40	100	160



DIN 763 Link Chain

Size d		Inside Length t		Outside Width b		Working Load kg	Test Load n	Breaking Load n	Weight Per M kg
mm	± mm	mm	± mm	mm	± mm				
2	0.5	22	1.0	8	0.4	25	800	1250	0.06
2.5		24	1.1	10	0.5	40	800	2000	0.10
3		26	1.2	12	0.6	55	1050	3200	0.15
3.5		28	1.3	14	0.7	80	1540	3850	0.20
4		32	1.5	16	0.8	100	2500	6500	0.27
4.5		34	1.7	18	0.9	128	3000	8000	0.35
5		35	1.8	20	1.0	160	4000	10000	0.43
5.5		38.5	1.8	22	1.1	195	4200	10500	0.52
6		42	2.0	24	1.2	200	5000	12000	0.63
7		49	2.5	28	1.4	300	7500	19000	0.86
8		52	2.5	32	1.6	400	10000	25000	1.10
8.5		56	2.8	34	1.7	460	10200	25500	1.25
9		59	3.0	36	1.8	530	10500	32000	1.41
10		65	3.2	40	2.0	630	16000	40000	1.75
11		72	3.4	44	2.0	790	15800	47500	2.11
12	78	3.6	48	2.3	940	18800	56500	2.55	
13	82	4.0	52	2.5	1000	25000	63000	2.95	
16	100	5.0	64	3.2	1600	40000	100000	4.45	
18	113	5.2	70	3.2	2120	42300	127000	5.65	
19	119	5.6	72	3.4	2370	47300	142000	6.25	
20	120	6.0	75	3.8	2500	50000	160000	7.00	
22	127	6.0	82	4.0	3170	63300	190000	8.55	
25	140	6.6	85	4.2	4090	81700	245000	10.9	
28	152	7.0	96	4.7	6000	120000	300000	13.9	
32	171	7.8	108	5.2	8000	160000	400000	18.2	

CHAIN

DIN 764 Link Chain

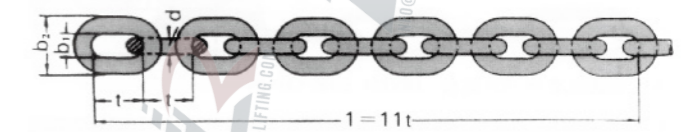

Size d		Inside Length t		Inside Width b1	Outside Width b2	Length Per 11 Links		Weight Per 100m	Breaking Load	Test Load
mm	± mm	mm	± mm	mm	mm	mm	± mm	kg	kn	kg
4	0.2	16	0.3	5	14	176	1.6	31.3	7	400
			0.2				0.9			
5	0.2	18	0.4	7	18.2	198	1.8	51.4	11.8	680
			0.2				1			
6	0.2	21	0.5	8	21.5	231	2	74	16.5	850
			0.2				1.1			
8	0.2	28	0.5	11	29	308	2.2	131.5	32	1680
			0.3				1.2			
10	0.3	35	0.6	14	36	385	2.7	200	50	2630
			0.3				1.5			
12	0.3	42	0.6	16	41	462	3.2	298	70	3680
			0.3				1.8			
13	0.4	45	0.7	18	47	495	3.5	350	80	4200
			0.4				2			
14	0.45	49	0.75	20	48	539	3.8	406	92	4830
			0.45				2			
16	0.5	56	0.9	22	58	616	4.3	520	125	6700
			0.5				2.5			
18	0.8	63	1	24	65	693	4.7	650	160	8400
			0.5				2.8			
20	1	70	1.1	27	72	770	5.4	820	200	10000
			0.6				3.2			
23	1.2	80	1.3	31	83	880	6.2	1100	250	13000
			0.7				3.5			
26	1.3	91	1.5	35	94	1001	7	1400	320	16000
			0.8				4			
28	1.4	98	1.6	36	101	1078	7.5	1650	360	18000
			0.9				4.3			
30	1.5	105	1.7	39	108	1156	7.8	1900	415	20750
			0.9				4.6			
33	1.7	115	1.9	43	119	1265	8.5	2250	500	25000
			1				4.9			

CHAIN

CHAIN

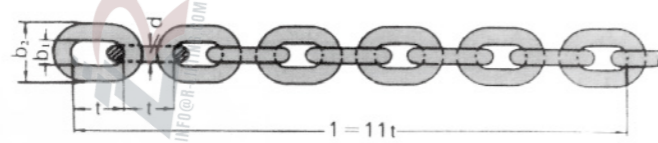

DIN 766 Link Chain

Size d		Inside Length t			Inside Width b1	Outside Width b2	Length Per 11 Links			Weight Per M kg	Breaking Load kn
mm	±mm	mm	+mm	-mm			mm	+mm	-mm		
2	0.2	12	0.2	0.2	3.5	7.5	132	1	0.5	0.07	1.25
3	0.2	16	0.2	0.2	4.2	11	176	1.4	0.7	0.16	4
4	0.2	16	0.3	0.2	5.0	13.7	176	2.1	1.1	0.32	8
5	0.2	18.5	0.4	0.2	6.0	17	203.5	2.4	1.2	0.5	12.5
6	0.2	18.5	0.4	0.2	7.2	20.2	203.5	2.4	1.2	0.8	16
7	0.3	22	0.4	0.2	8.4	23.8	242	3	1.4	1.1	25
8	0.3	24	0.4	0.2	9.6	27.2	264	3.2	1.5	1.4	32
9	0.4	27	0.5	0.3	10.8	30.6	297	3.6	1.8	1.8	40
10	0.4	28	0.5	0.3	12	34	308	3.7	1.9	2.2	50
11	0.4	31	0.5	0.3	13.2	37.4	341	4	2	2.7	63
12	0.3	36	0.6	0.3	14.4	40.8	396	4.4	2.2	3.1	72.4
13	0.5	36	0.6	0.3	15.6	44.2	396	4.6	2.4	3.8	80
14	0.6	41	0.7	0.4	16.8	47.6	451	5.4	2.7	4.4	100
16	0.6	45	0.8	0.4	19.2	54.4	495	6	3	5.7	125
18	0.9	50	0.8	0.4	21.6	61.2	550	6.6	3.3	7.3	160
19	0.4	53	0.9	0.4	22.8	64.6	583	7	3.7	7.97	180
20	1.0	56	1.0	0.5	24	68	616	7.4	3.7	9	200
22	1.2	62	1.1	0.5	26.4	75	682	8	4	11	243
23	1.2	64	1.1	0.5	27.6	78.2	704	8.4	4.2	12	250
26	1.3	73	1.2	0.6	31.2	88.4	803	9.6	4.8	15	320
28	1.4	78	1.3	0.65	33.8	95.2	858	10.2	5.1	18	400
30	1.5	84	1.4	0.7	41	102	924	11	5.5	19.5	450
32	1.6	90	1.5	0.75	43	108.8	990	11.8	5.9	23	500

CHAIN

CHAIN

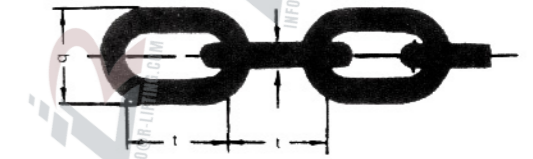

DIN 5685A/C Short/Long Link Chain

Size d mm	Inside Length t mm	Outside Width b mm	Weight Per 100m Kg	Test Load N	Breaking Load N	Type of Link
2	12	8	7	500	1250	A
	22		6			C
2.5	14	10	11	750	2000	A
	24		10			C
3	16	12	16.5	1120	2800	A
	26		15			C
3.5	18	14	22.5	1500	3850	A
	28		20			C
4	19	16	30	2000	5000	A
	32		27			C
4.5	20	18	39.5	2500	6300	A
	34		35			C
5	21	20	50	3150	7750	A
	35		43			C
5.5	23	22	60.5	3800	9500	A
	38.5		52			C
6	24	24	73	4500	11500	A
	42		63			C
6.5	26	26	86	5400	13500	A
	45.5		74			C
7	28	28	100	6000	15000	A
	49		86			C
8	32	32	130	8000	20000	A
	52		110			C
8.5	34	34	149	9000	22500	A
	56		125			C
9	36	36	165	10000	25000	A
	59		141			C
10	40	40	205	12500	31000	A
	65		175			C
11	44	44	250	15000	38000	A
	72		211			C
12	48	48	290	18000	45000	A
	78		255			C
13	52	52	345	21200	53000	A
	82		295			C

LIFTING SLING

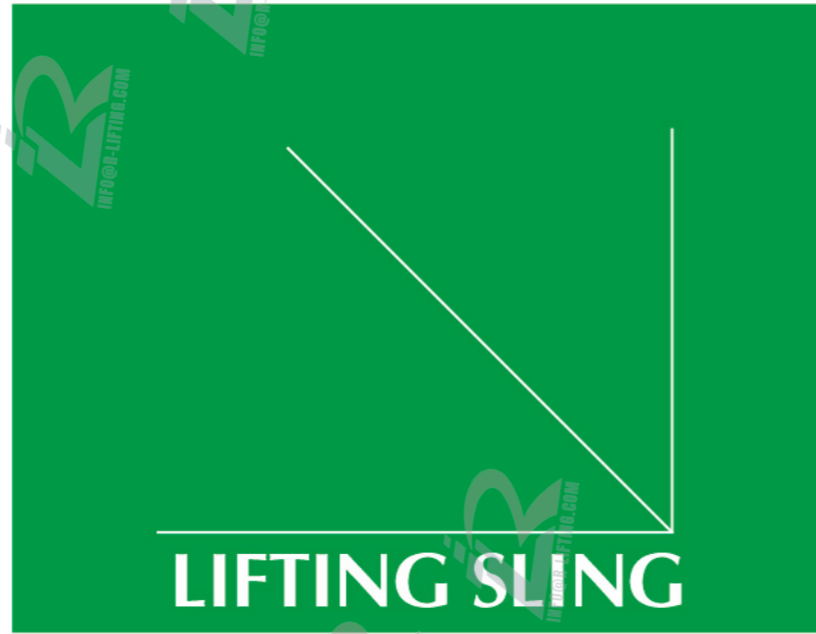

Wire Rope End Terminations

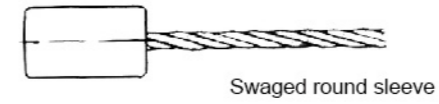

Swaged round sleeve



Hand spliced eye

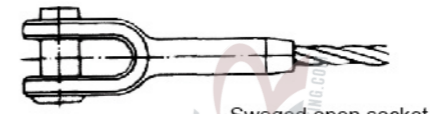

Swaged open socket



Spliced thimble

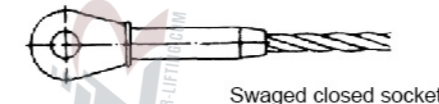

Swaged closed socket

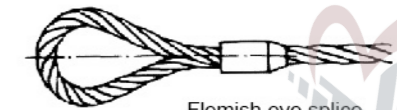

Flemish eye splice

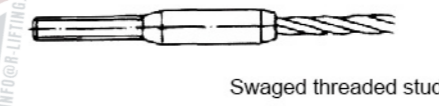

Swaged threaded stud

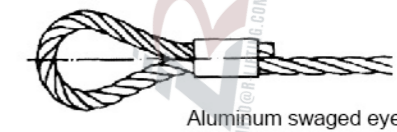

Aluminum swaged eye

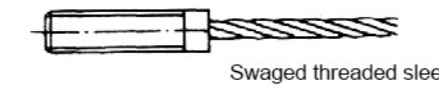

Swaged threaded sleeve

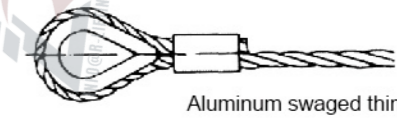

Aluminum swaged thimble



Wedge type socket

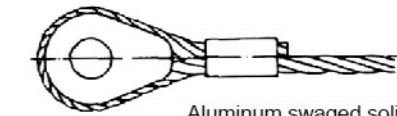

Aluminum swaged solid thimble



Wire rope grip

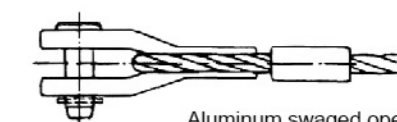

Aluminum swaged open socket

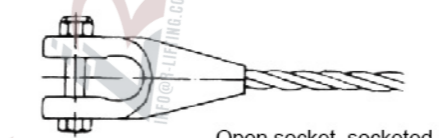

Open socket, socketed

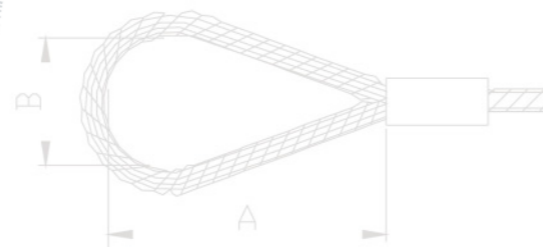

LIFTING SLING

Types of Sling



Sling with soft eye



Sling with soft eye two legs

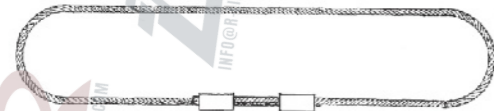

Sling with round



Sling with single hook



Sling for crane



Sling with master link two legs



Sling with master link four legs



Containers sling for sea oil



Sling for ship used



Sling for spiral burr steel



Sling for steel plate



Assembly sling for spiral burr steel with wire rope and chain

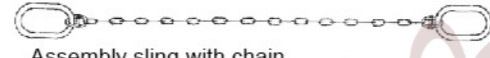

Assembly sling with chain

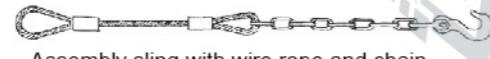

Assembly sling with wire rope and chain



Chain sling with hooks two legs



Chain sling with hooks four legs



Special sling for power cable



Dee type polyester webbing sung



Single endless polyester webbing sung



Sling with socket



Hoist sling for crane



Sling with spliced eye termination

WS01 Swaged Soft Eye Slings

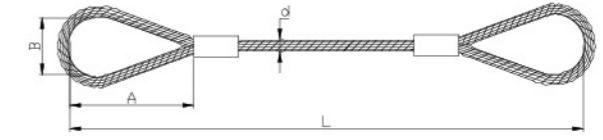

Part No.	Rope dia. d (mm)	Soft loop dimensions (mm)		M.B.L. (t)	Working load limit (t)	
		A	B		n = 5	n = 6
WS010050	5	130	65	1.25	0.25	0.20
WS010060	6	150	75	1.80	0.36	0.30
WS010070	7	150	75	2.46	0.50	0.40
WS010080	8	200	100	3.21	0.60	0.50
WS010090	9	200	100	4.07	0.80	0.70
WS010100	10	200	100	5.03	1.00	0.80
WS010110	11	230	115	6.08	1.20	1.00
WS010120	12	230	115	7.23	1.50	1.20
WS010130	13	230	115	8.49	1.70	1.40
WS010140	14	250	125	9.85	2.00	1.60
WS010160	16	300	150	12.85	2.60	2.10
WS010180	18	300	150	16.32	3.30	2.70
WS010200	20	350	175	20.09	4.00	3.40
WS010220	22	350	175	24.27	4.90	4.10
WS010240	24	450	225	28.96	5.80	4.80
WS010260	26	450	225	33.96	6.80	5.70
WS010280	28	500	250	39.36	7.90	6.60
WS010300	30	500	250	45.17	9.00	7.50
WS010320	32	550	275	51.39	10.30	8.60
WS010340	34	600	300	58.12	11.60	9.70
WS010360	36	600	300	65.06	13.00	10.80
WS010380	38	600	300	72.50	14.50	12.10
WS010400	40	700	350	80.35	16.10	13.40
WS010420	42	800	400	88.61	17.70	14.80
WS010440	44	800	400	97.28	19.50	16.20
WS010460	46	900	450	106.05	21.20	17.70
WS010480	48	900	450	116.25	23.30	19.40
WS010500	50	1000	500	125.43	25.10	21.00
WS010520	52	1000	500	135.62	27.10	22.70

Part No.	Rope dia. d (mm)	Soft loop dimensions (mm)		M.B.L. (t)	Working load limit (t)	
		A	B		n = 5	n = 6
WS010540	54	1000	500	146.84	29.40	24.50
WS010560	56	1000	500	157.04	31.40	26.20
WS010580	58	1200	600	169.27	33.90	28.20
WS010600	60	1200	600	180.49	36.10	30.10
WS010620	62	1200	600	185.59	37.10	31.00
WS010640	64	1300	650	197.82	40.00	33.00
WS010660	66	1300	650	210.06	42.00	35.00
WS010680	68	1400	700	223.32	44.70	37.20
WS010700	70	1400	700	236.57	47.30	39.40
WS010720	72	1400	700	249.93	50.00	41.60
WS010740	74	1500	750	26.014	52.80	44.00
WS010760	76	1500	750	278.38	55.70	46.40
WS010780	78	1600	800	293.68	58.70	49.00
WS010800	80	1600	800	307.95	61.10	51.30
WS010820	82	1600	800	324.27	64.90	54.00
WS010840	84	1700	850	339.57	67.90	56.60
WS010860	86	1700	850	356.90	71.40	59.50
WS010880	88	1800	900	373.22	74.60	62.20
WS010900	90	1800	900	390.55	78.10	65.10
WS010920	92	1800	900	407.89	81.60	68.00
WS010940	94	1900	950	426.24	85.30	71.00
WS010960	96	1900	950	444.60	88.90	74.10
WS010980	98	2000	1000	462.95	92.60	77.20
WS011000	100	2000	1000	482.33	96.50	80.40
WS011020	102	2000	1000	501.10	100.40	83.60
WS011040	104	2100	1050	521.07	104.20	86.90
WS011060	106	2100	1050	541.47	108.30	90.30
WS011080	108	2200	1100	561.86	112.40	93.60
WS011100	110	2200	1100	583.28	116.70	97.20

Note:

1. Steel wire ropes with diameters from Ø5 to Ø60 are 6×37+FC-1670N/mm² type complying to the GB/T20118 standard, while the ones with diameters from Ø62 to Ø110 are 6×61+FC-1670N/mm² type complying to the GB/T20067 standard.
2. Values "A" or "B" can be customized. Otherwise, the values in the table apply.
3. "L" value meets client requirements; n=5 and n=6 are safety factors, determined by users.

LIFTING SLING

WS02 Spliced Soft Eye Slings

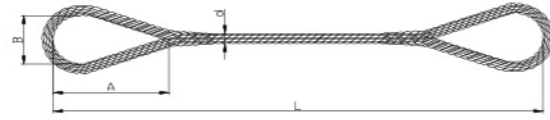
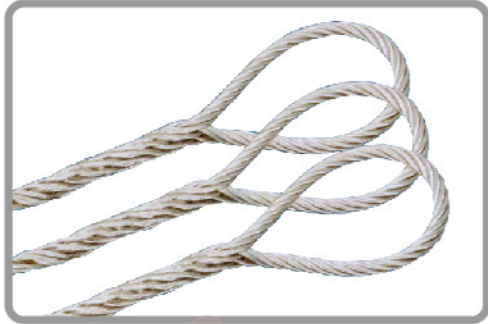

Part No.	Rope dia. d (mm)	Soft loop dimensions (mm)		M.B.L. (t)	Working load limit (t)	
		A	B		n = 5	n = 6
WS020050	5	130	65	1.25	0.24	0.20
WS020060	6	150	75	1.80	0.34	0.28
WS020070	7	150	75	2.46	0.48	0.38
WS020080	8	200	100	3.21	0.60	0.50
WS020090	9	200	100	4.07	0.72	0.60
WS020100	10	200	100	5.03	0.90	0.75
WS020110	11	230	115	6.08	1.10	0.90
WS020120	12	230	115	7.23	1.30	1.10
WS020130	13	230	115	8.49	1.50	1.30
WS020140	14	250	125	9.85	1.80	1.50
WS020160	16	300	150	12.85	2.30	1.90
WS020180	18	300	150	16.32	2.90	2.40
WS020200	20	350	175	20.09	3.60	3.00
WS020220	22	350	175	24.27	3.90	3.20
WS020240	24	450	225	28.96	4.60	3.90
WS020260	26	450	225	33.96	5.40	4.50
WS020280	28	500	250	39.36	6.30	5.20
WS020300	30	500	250	45.17	7.20	6.00
WS020320	32	550	275	51.39	7.70	6.40
WS020340	34	600	300	58.12	8.70	7.30
WS020360	36	600	300	65.06	9.80	8.10
WS020380	38	600	300	72.50	10.90	9.10
WS020400	40	700	350	80.35	12.10	10.00
WS020420	42	800	400	88.61	12.40	10.30
WS020440	44	800	400	97.28	13.60	11.30
WS020460	46	900	450	106.05	14.80	12.40
WS020480	48	900	450	116.25	16.30	13.60
WS020500	50	1000	500	125.43	17.60	14.60
WS020520	52	1000	500	135.62	19.00	15.80

Part No.	Rope dia. d (mm)	Soft loop dimensions (mm)		M.B.L. (t)	Working load limit (t)	
		A	B		n = 5	n = 6
WS020540	54	1000	500	146.84	20.60	17.10
WS020560	56	1000	500	157.04	22.00	18.30
WS020580	58	1200	600	169.27	23.70	19.70
WS020600	60	1200	600	180.49	25.30	21.10
WS020620	62	1200	600	185.59	26.00	21.70
WS020640	64	1300	650	197.82	27.70	23.10
WS020660	66	1300	650	210.06	29.40	24.50
WS020680	68	1400	700	223.32	31.30	26.10
WS020700	70	1400	700	236.57	33.10	27.60
WS020720	72	1400	700	249.93	35.00	29.20
WS020740	74	1500	750	264.11	37.00	30.80
WS020760	76	1500	750	278.38	39.00	32.50
WS020780	78	1600	800	293.68	41.10	34.30
WS020800	80	1600	800	307.95	43.10	35.90
WS020820	82	1600	800	324.27	45.40	37.80
WS020840	84	1700	850	339.57	47.50	39.60
WS020860	86	1700	850	356.90	50.00	41.60
WS020880	88	1800	900	373.22	52.30	43.50
WS020900	90	1800	900	390.55	54.70	45.60
WS020920	92	1800	900	407.89	57.10	47.60
WS020940	94	1900	950	426.24	59.70	49.70
WS020960	96	1900	950	444.60	62.20	51.90
WS020980	98	2000	1000	462.95	64.80	54.00
WS021000	100	2000	1000	482.33	67.50	56.30
WS021020	102	2000	1000	501.10	70.20	58.50
WS021040	104	2100	1050	521.07	72.90	60.80
WS021060	106	2100	1050	541.47	75.80	63.20
WS021080	108	2200	1100	561.86	78.70	65.60
WS021100	110	2200	1100	583.28	81.70	68.00

Note:

1. Steel wire ropes with diameters from Ø5 to Ø60 are 6x37+FC-1670N/mm² type complying to the GB/T20118 standard, while the ones with diameters from Ø62 to Ø110 are 6x61+FC-1670N/mm² type complying to the GB/T20067 standard.
2. Values "A" or "B" can be customized. Otherwise, the values in the table apply.
3. "L" value meets client requirements; n=5 and n=6 are safety factors, determined by users.

LIFTING SLING

Flemish Eye Splice



- The wire rope slings pressed with steel sleeves are manufactured according to the EN13414 standard.
- Steel wire rope with diameters from 5mm-130mm can be pressed with steel sleeves, and the Minimum Breaking Load is 5 times of Working Load Limited.
- All the products can pass the 2 times safety tensile test or breaking load test. Certificate of Quality and Certificate of Tensile Test can be offered.
- Wire ropes with different structures have different working load. And working load can be figured out according to the wire rope structure required.

WS03 6x37+IWRC-1770Mpa

Part No.	Rope Dia (mm)	Working Load Limited(Ton)						Eye Size (mm)	
		Vertical	Choker	Basket Hitches			A	B	
				60°	45°	30°			
WS030100	10	1.2	0.9	2.4	2.0	1.7	1.2	200	100
WS030120	12	1.8	1.4	3.6	3.1	2.5	1.8	240	120
WS030140	14	2.3	1.8	4.6	4.0	3.2	2.3	280	140
WS030160	16	3.0	2.0	6.0	5.0	4.0	3.0	320	160
WS030180	18	4.0	3.0	8.0	7.0	6.0	4.0	360	180
WS030200	20	5.0	4.0	10.0	8.0	7.0	5.0	400	200
WS030220	22	6.0	5.0	12.0	10.0	8.0	6.0	440	220
WS030240	24	7.0	5.0	14.0	12.0	10.0	7.0	480	240
WS030260	26	8.0	6.0	16.0	14.0	11.0	8.0	520	260
WS030280	28	9.0	7.0	18.0	16.0	13.0	9.0	560	280
WS030300	30	11.0	9.0	22.0	19.0	15.0	11.0	600	300
WS030320	32	12.0	10.0	24.0	21.0	17.0	12.0	640	320
WS030340	34	14.0	11.0	28.0	24.0	19.0	14.0	680	340
WS030360	36	15.0	12.0	30.0	27.0	22.0	15.0	720	360
WS030380	38	17.0	14.0	34.0	30.0	24.0	17.0	760	380
WS030400	40	19.0	15.0	38.0	33.0	27.0	19.0	800	400
WS030420	42	21.0	17.0	42.0	37.0	30.0	21.0	840	420
WS030450	45	24.0	19.0	48.0	42.0	34.0	24.0	900	450
WS030500	50	30.0	24.0	60.0	52.0	42.0	30.0	1000	500
WS030520	52	32.0	26.0	64.0	56.0	46.0	32.0	1040	520
WS030560	56	37.0	30.0	74.0	65.0	53.0	37.0	1120	560
WS030600	60	43.0	34.0	86.0	75.0	61.0	43.0	1200	600
WS030650	65	50.0	40.0	100.0	87.0	71.0	50.0	1300	650
WS030700	70	58.0	47.0	116.0	101.0	82.0	58.0	1400	700
WS030750	75	67.0	53.0	134.0	116.0	95.0	67.0	1500	750
WS030800	80	76.0	61.0	152.0	132.0	108.0	76.0	1600	800
WS030850	85	86.0	69.0	172.0	149.0	122.0	86.0	1700	850
WS030900	90	96.0	77.0	192.0	167.0	137.0	96.0	1800	900
WS030950	95	107.0	86.0	214.0	186.0	152.0	107.0	1900	950
WS031000	100	119.0	95.0	238.0	207.0	169.0	119.0	2000	1000
WS031020	102	120.0	96.0	240.0	208.0	170.0	120.0	2040	1020
WS031050	105	123.0	99.0	246.0	214.0	175.0	123.0	2100	1050

* WLL=MBL X 0.9 (Pressing Efficiency of Aluminum Ferrules)/5 (Safety Factor)

LIFTING SLING

WS04 Cast in Lift Anchor



Part No.	θ (mm)	Load(ton)	Height(mm)	Width(mm)
WS040060	6	0.8	200	50
WS040080	8	1.6	235	70
WS040100	10	2.5	280	80
WS040140	14	5.2	385	180
WS040160	16	6.3	385	180
WS040200	20	10	470	200
WS040220	22	12.5	510	200
WS040240	24	16	560	220
WS040280	28	20	610	280

WS05 Rd-thread Lift Loop



Part No.	d*e(mm)	θ (mm)	Load(ton)	Height(mm)
WS050060	Rd12*22	6	0.5	155
WS050070	Rd14*24	7	0.8	155
WS050080	Rd16*27	8	1.2	155
WS050100	Rd20*35	10	2	215
WS050160	Rd30*50	16	4	300
WS050180	Rd36*65	18	6.3	340
WS050200	Rd42*70	20	8	425
WS050260	Rd52*80	26	12.5	480

WS06 M-thread Lift Loop



Part No.	d*e(mm)	Load(ton)	Height(mm)	Width(mm)
WS060060	M12*22	6	0.5	155
WS060070	M14*24	7	0.8	155
WS060080	M16*27	8	1.2	155
WS060100	M20*35	10	2	215
WS060160	M30*50	16	4	300
WS060180	M36*65	18	6.3	340
WS060200	M42*70	20	8	425
WS060260	M52*80	26	12.5	480

LIFTING SLING



WS20 Endless Locking Type(6x37+IWRC)

Part No.	Rope Dia (mm)	Working Load Limited(Ton)					
		Vertical	Choker	Basket Hitches			
WS200100	10	2.1	1.6	4.2	3.7	2.9	2.1
WS200120	12	3.2	2.3	6.3	5.5	4.4	3.2
WS200140	14	4	3	8	7	6	4
WS200160	16	5	4	11	9	7	5
WS200180	18	7	5	13	12	9	7
WS200200	20	8	6	16	14	11	8
WS200220	22	10	7.5	20	17	14	10
WS200240	24	12	9	24	21	17	12
WS200260	26	14	11	29	25	20	14
WS200280	28	17	13	33	29	23	17
WS200300	30	19	14	38	33	27	19
WS200320	32	21	16	42	37	30	21
WS200340	34	24	18	48	42	34	24
WS200360	36	27	20	54	47	38	27
WS200380	38	30	23	60	52	42	30
WS200400	40	34	26	68	60	47	34
WS200420	42	37	28	74	65	52	37
WS200450	45	43	33	86	75	60	43
WS200500	50	53	40	106	93	74	53
WS200520	52	56	43	112	99	78	56
WS200560	56	66	50	132	117	93	66
WS200600	60	76	58	152	134	107	76
WS200650	65	89	68	179	157	125	89
WS200700	70	104	79	208	183	146	104
WS200750	75	119	90	237	209	166	119
WS200780	78	129	98	257	226	180	129
WS200820	82	142	108	285	251	199	142
WS200870	87	156	119	313	275	219	156
WS200920	92	179	136	358	315	250	179
WS200950	95	191	145	382	336	267	191
WS201000	100	203	154	406	357	284	203
WS201020	102	219	167	438	386	307	219
WS201050	105	232	176	463	408	324	232

* WLL=MBL X 0.9 (Pressing Efficiency of Aluminum Ferrules)/5 (Safety Factor)

LIFTING SLING

WS21 Endless Wire Rope Slings

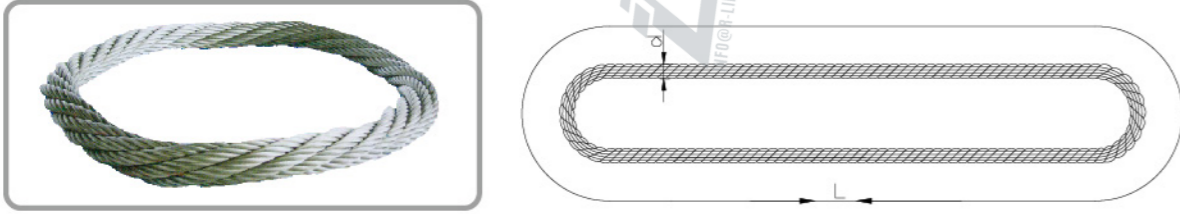

Part No.	Nominal dia. d (mm)	Breaking load (KN)	Vertical working load of single leg (KN)		Working load of double leg (KN)		Working load of four leg (KN)		Approx. weight (kg/m)
			α=0°		α≤45°		α≤45°		
			α=0°	α≤45°	45°≤α≤90°	α≤45°	45°≤α≤90°		
WS210100	10	60	10	18	14	36	28	0.29	
WS210120	12	100	16	30	22	60	44	0.48	
WS210150	15	140	23	41	32	82	64	0.71	
WS210180	18	180	30	54	42	108	84	0.98	
WS210210	21	235	39	70	55	140	110	1.11	
WS210240	24	305	51	92	70	184	140	1.44	
WS210270	27	385	64	115	90	230	180	1.82	
WS210300	30	475	79	142	110	284	220	2.25	
WS210360	36	605	114	205	160	410	320	3.39	
WS210420	42	930	155	280	217	560	434	4.61	
WS210480	48	1220	203	365	284	730	568	6.02	
WS210540	54	1540	256	460	358	920	716	7.62	
WS210600	60	1900	316	570	442	1140	884	9.38	
WS210660	66	2305	384	690	538	1380	1076	11.36	
WS210720	72	2745	458	824	640	1648	1280	13.53	
WS210780	78	3220	536	964	750	1928	1500	15.91	
WS210840	84	3730	622	1120	870	2240	1740	18.43	
WS210900	90	4285	714	1285	1000	2570	2000	21.15	
WS210960	96	4880	812	1462	1136	2924	2274	24.07	
WS211020	102	5510	918	1652	1285	3304	2570	27.20	
WS211080	108	6175	1030	1854	1442	3708	2884	30.46	
WS211140	114	6875	1146	2062	1604	4124	3208	34.00	
WS211200	120	7615	1270	2286	1778	4572	3556	37.67	
WS211260	126	8400	1400	2520	1960	5040	3920	41.48	
WS211320	132	9210	1535	2763	2150	5526	4300	45.56	
WS211380	138	10032	1672	3010	2340	6020	4680	49.78	
WS211440	144	10945	1824	3282	2554	6564	5108	54.20	
WS211500	150	11855	1976	3556	2766	7112	5532	58.82	
WS211560	156	12860	2144	3860	3002	7720	6004	63.65	
WS211620	162	13860	2310	4158	3234	8316	6468	68.68	
WS211680	168	14955	2492	4486	3488	8972	6976	74.12	
WS211740	174	16050	2675	4815	3745	9630	7490	78.88	
WS211800	180	17145	2858	5144	4000	10288	8000	85.00	
WS211860	186	17600	2934	5282	4108	10564	8216	94.52	
WS211920	192	18695	3116	5608	4362	11216	8724	100.6	
WS211980	198	19800	3300	5940	4620	11880	9240	106.8	
WS212040	204	21160	3526	6346	4936	12692	9872	113.6	
WS212100	210	22345	3724	6702	5214	13404	10428	120.4	
WS212160	216	23710	3950	7110	5530	14220	11060	127.2	
WS212220	222	24990	4165	7498	5830	14995	11660	134.6	
WS212280	228	26355	4392	7906	6150	15812	12300	142.1	
WS212340	234	27815	4636	8345	6490	16690	12980	149.6	
WS212400	240	29275	4880	8784	6832	17568	13664	157.1	

Note: Safety factor 6:1, for use in general frequent lifting environment.

LIFTING SLING

WS22 Large Diameter Cable-Laid Slings

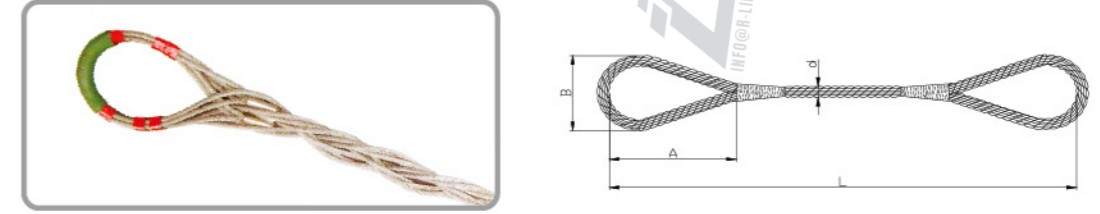

Part No.	Nominal dia. d (mm)	Main rope dia. (mm)	Core rope dia. (mm)	Breaking load		Working load limit		Approx. weight (kg/m)
				(KN)	(t)	(KN)	(t)	
WS220700	70	22	26	1460	149	304	31	15.62
WS220760	76	24	28	1736	177	373	38	18.54
WS220820	82	26	30	2039	208	451	46	21.67
WS220900	90	28	34	2363	240	539	55	25.61
WS220960	96	30	36	2713	277	647	66	29.24
WS221020	102	32	38	3089	315	756	77	33.15
WS221080	108	34	40	3486	355	882	90	37.28
WS221140	114	36	42	3905	398	1022	104	41.69
WS221200	120	38	44	4363	445	1182	120	46.32
WS221260	126	40	46	4838	493	1360	139	51.18
WS221320	132	42	48	5314	542	1551	158	56.27
WS221440	144	46	52	6394	652	2022	206	67.24
WS221500	150	48	54	6955	709	2295	234	73.13
WS221560	156	50	56	7517	767	2506	256	78.90
WS221620	162	52	58	8165	833	2722	278	85.59
WS221680	168	54	60	8770	894	2923	298	92.17
WS221740	174	56	62	9461	965	3154	322	98.96
WS221800	180	58	64	10152	1035	3384	345	106.28
WS221920	192	62	68	11578	1181	3859	394	121.12
WS222040	204	66	72	13133	1339	4378	446	136.79
WS222160	216	68	80	13954	1423	4651	474	149.00
WS222280	228	74	80	16502	1683	5500	560	171.59
WS222400	240	76	88	17410	1775	5803	592	184.97
WS222520	252	80	92	19310	1969	6437	656	205.03
WS222640	264	84	96	21254	2167	7085	722	225.20
WS222760	276	88	100	23328	2379	7776	793	246.83
WS222880	288	90	108	24408	2489	8136	830	265.53
WS223000	300	96	108	26525	2705	8842	902	294.38
WS223120	312	100	112	28771	2934	9591	978	319.14
WS223360	336	108	120	32616	3326	10866	1108	383.31
WS223600	360	116	128	37627	3837	12542	1280	441.30
WS223840	384	124	136	42984	4383	14328	1460	503.59
WS224080	408	130	148	47088	4802	15696	1600	560.43
WS224320	432	138	156	53136	5418	17712	1806	629.93
WS224560	456	146	164	56592	5771	18864	1924	705.58

Note:

- Steel wire ropes with diameters from Ø67 to Ø456 are 6×36WS+IWR, 6×65WS+IWR types complying to the GB/T20118 and GB/T20067 standards.
- Large diameter steel cable twisting joint riggings are manufactured according to the EN13414 standard, and the safety factor should be selected according to the EN13414 standard.

LIFTING SLING

WS31 Single-leg Swaged Sling Assembly

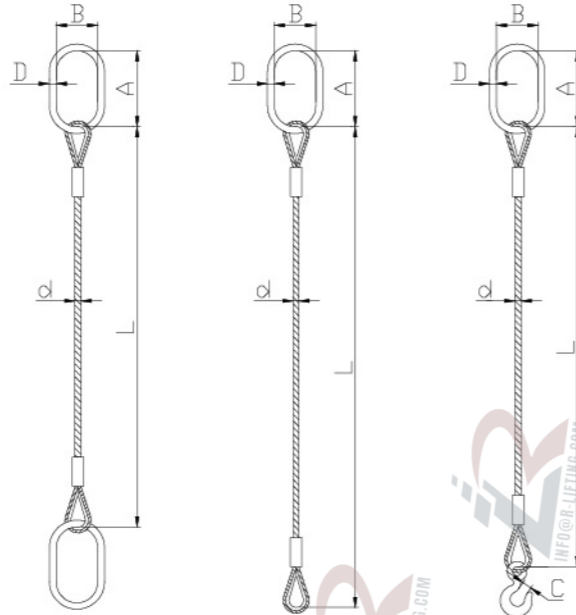

Part No.	Rope dia.(mm)	Working load limit (KN)	Loop dimension A×B×D (mm)	Dimension of hook opening C (mm)
WS310060	6	2.90	110x60x14	24
WS310080	8	4.90	110x60x14	24
WS310100	10	7.90	110x60x14	24
WS310120	12	11.80	110x60x16	25
WS310140	14	15.70	110x60x16	27
WS310160	16	21.60	135x75x18	30
WS310180	18	26.50	135x75x18	38
WS310200	20	32.40	160x90x22	38
WS310240	24	49.00	160x90x22	38
WS310280	28	68.60	180x100x26	45
WS310320	32	88.30	200x110x32	61
WS310380	38	117.70	260x140x36	67
WS310400	40	132.40	260x140x36	67
WS310440	44	147.00	300x160x40	67
WS310520	52	216.00	350x190x50	87
WS310560	56	257.00	350x190x50	87
WS310640	64	335.00	400x200x56	108
WS310700	70	400.00	400x200x56	108

Note:

1. The steel wire ropes are 1670N/mm² fiber core type.
2. "L" value meets client requirements.

LIFTING SLING

WS32 Double-leg Swaged Sling Assembly

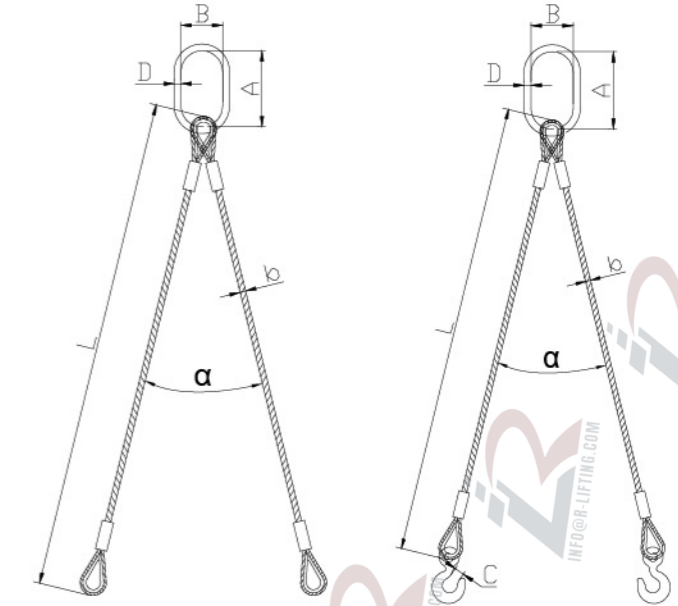

Part No.	Rope dia. (mm)	Working load limit (KN)	Working load limit (KN)	Loop dimension A×B×D (mm)	Dimension of hook opening C (mm)
		$\alpha < 90^\circ$	$90^\circ \leq \alpha \leq 120^\circ$		
WS320060	6	4.10	2.90	110x60x14	24
WS320080	8	6.90	4.90	110x60x14	24
WS320100	10	11.00	7.90	110x60x16	25
WS320120	12	16.50	11.80	110x60x16	25
WS320140	14	22.00	15.70	135x75x18	27
WS320160	16	30.00	21.60	135x75x18	30
WS320180	18	37.00	26.50	160x90x22	38
WS320200	20	45.00	32.40	160x90x22	38
WS320240	24	68.60	49.00	180x100x26	45
WS320280	28	96.00	68.60	200x110x32	61
WS320320	32	123.60	88.30	260x140x36	66
WS320380	38	165.00	117.70	300x160x40	87
WS320400	40	185.00	132.40	340x180x45	87
WS320440	44	206.00	147.00	340x180x45	87
WS320520	52	302.40	216.00	350x190x50	102
WS320560	56	359.80	257.00	400x200x56	107
WS320640	64	469.00	335.00	430x220x63	121
WS320700	70	560.00	400.00	460x250x72	146

Note:

1. The steel wire ropes are 1670N/mm² fiber core type.
2. "L" value meets client requirements.

LIFTING SLING

WS33 Four-leg Swaged Sling Assembly

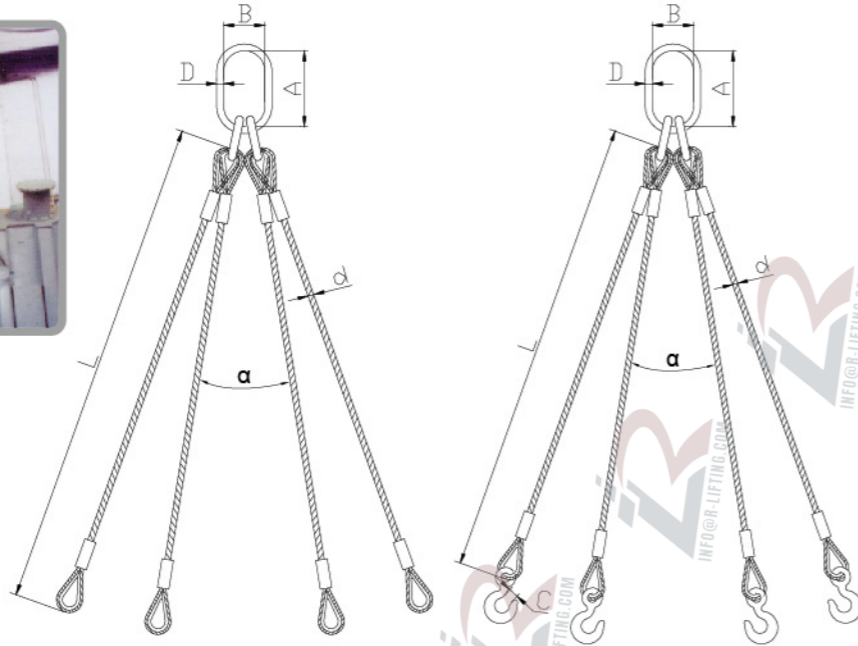

Part No.	Rope dia. (mm)	Working load limit (KN) $\alpha \leq 90^\circ$	Working load limit (KN) $90^\circ \leq \alpha \leq 120^\circ$	Main loop dimension AxBxD (mm)	Assistant loop dimension AxBxD (mm)	Dimension of hook opening C (mm)
WS330060	6	6.10	4.40	100x60x14	85x40x12	24
WS330080	8	10.30	7.40	100x60x14	85x40x12	25
WS330100	10	16.60	11.90	100x60x14	85x40x12	27
WS330120	12	24.80	17.70	160x90x18	100x60x14	30
WS330140	14	33.00	23.60	160x90x20	100x60x14	38
WS330160	16	45.40	32.40	180x100x22	150x70x18	38
WS330180	18	55.70	39.80	180x100x22	150x70x18	45
WS330200	20	68.00	48.60	270x140x28	160x90x22	45
WS330240	24	102.90	73.50	270x140x32	180x100x25	61
WS330280	28	144.10	102.90	260x140x36	—	66
WS330320	32	185.40	132.50	340x180x45	—	87
WS330380	38	247.00	176.60	340x180x50	—	102
WS330400	40	278.00	199.00	340x180x50	—	102
WS330440	44	309.00	221.00	340x180x50	—	108
WS330520	52	450.00	324.00	430x220x63	—	121
WS330560	56	540.00	386.00	460x250x72	—	146

Note:

1. The steel wire ropes are 1670N/mm² fiber core type.
2. "L" value meets client requirements.

LIFTING SLING

Cable Stockings

Cable Stocking is a woven wire rope sleeve with an eye or eyes at the end, the sleeve is designed to fit onto a wire rope or cable to become an attachment point for hauling, or for securing the wire rope or cable during installation.

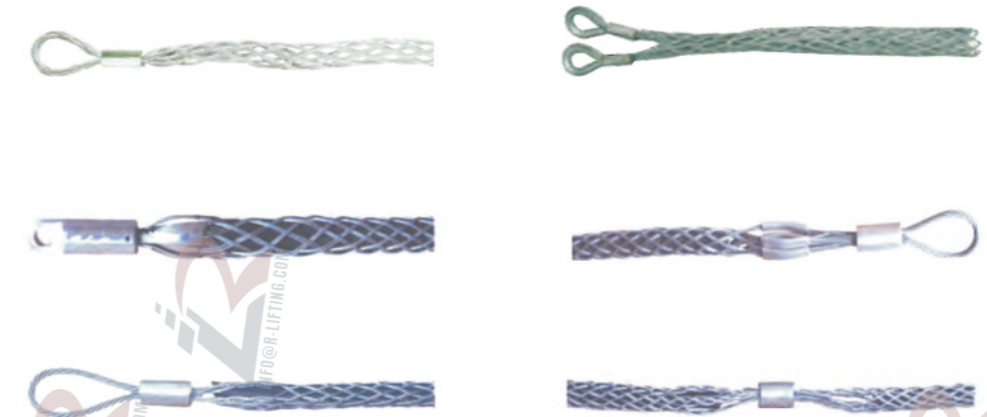

WS51 Double Eye Cable Stockings (Type B)

- This is similar to the single eye type and has similar applications. The extra eye is provided to lift the assembly while the other eye is made off to a fixture.
- Type B double Type eye cable stockings are made of galvanized steel wire and aluminium alloy ferrule.



Part No.	Hose OD (mm)	Overall length (mm)	Eye dimension (mm)	Number of strands	Breaking load (KN)
WS510408	4-8	300	50	8	10.24
WS510812A	8-12	400	57	8	10.56
WS510812B	8-12	400	57	12	15.84
WS511320	13-20	580	57	8	10.56
WS512232	22-32	690	57	8	10.56
WS513332	33-32	690	57	12	15.84
WS513444	34-44	910	62	12	25.20
WS514555	45-55	1120	62	12	25.20
WS515666	56-66	1300	75	12	25.20
WS515666	56-66	1300	75	12	37.80
WS517082	70-82	1560	95	12	37.80
WS5185XX	85-100	2250	100	12	35.44
WS51104X	104-130	2250	130	12	56.40

LIFTING SLING

WS52 Single Eye Cable Stockings (Type A)

- ▶ The eye is used for installing, lifting, or for hauling when the cable stocking is securely connected to a fixture.
- ▶ Type A single eye cable stockings are made of galvanized steel wire and aluminium alloy ferrule.



Part No.	Hose OD (mm)	Overall length (mm)	Eye dimension (mm)	Weave	Rope dia. (mm)	Breaking load (KN)
WS520508A	5-8	300	50	3×2	1.2	0.62
WS520508B	5-8	300	50	4×2	1.2	0.83
WS520812A	8-12	400	57	4×2	1.6	1.10
WS520812B	8-12	400	57	3×3	1.6	1.24
WS520812C	8-12	400	57	4×2	1.6	1.47
WS520812D	8-12	400	57	4×3	1.6	1.65
WS521222A	12-22	580	57	4×2	1.6	1.10
WS521222B	12-22	580	57	4×3	1.6	1.65
WS521222C	12-22	580	57	6×2	1.6	1.47
WS521222D	12-22	580	57	6×3	1.6	2.21
WS522333A	23-33	690	57	6×2	1.6	1.65
WS522333B	23-33	690	57	6×3	1.6	2.47
WS522333C	23-33	690	57	6×2	1.6	2.21
WS522333D	23-33	690	57	6×3	1.6	3.31
WS523444A	34-44	910	62	6×2	2.0	2.14
WS523444B	34-44	910	62	6×3	2.0	3.20
WS523444C	34-44	910	62	6×2	2.0	3.00
WS523444D	34-44	910	62	6×3	2.0	4.50
WS524555A	45-55	1120	62	6×2	2.0	2.14
WS524555B	45-55	1120	62	6×3	2.0	3.20
WS524555C	45-55	1120	62	6×2	2.0	3.00
WS524555D	45-55	1120	62	6×3	2.0	4.50
WS525666A	56-66	1300	75	6×2	2.5	3.25
WS525666B	56-66	1300	75	6×3	2.5	4.88
WS525666C	56-66	1300	75	6×2	2.5	4.27
WS525666D	56-66	1300	75	6×3	2.5	6.36
WS526782A	67-82	1560	95	6×2	2.5	3.25
WS526782B	67-82	1560	95	6×3	2.5	4.88
WS526782C	67-82	1560	95	6×2	2.5	4.24
WS526782D	67-82	1560	95	6×3	2.5	6.36
WS5283XXA	83-100	2250	100	6×2	3.0	4.78
WS5283XXB	83-100	2250	100	6×3	3.0	7.17
WS5283XXC	83-100	2250	100	6×2	3.0	7.22
WS5283XXD	83-100	2250	100	6×3	3.0	10.83
WS52100XA	100-130	2250	130	6×2	4.0	7.83
WS52100XB	100-130	2250	130	6×3	4.0	11.74
WS52100XC	100-130	2250	130	6×2	4.0	11.07
WS52100XD	100-130	2250	130	6×3	4.0	16.61
WS52130XA	130-180	3000	175	6×2	5.0	12.20
WS52130XB	130-180	3000	175	6×3	5.0	18.30
WS52130XC	130-180	3000	175	6×2	5.0	17.06
WS52130XD	130-180	3000	175	6×3	5.0	25.59

LIFTING SLING

WS61 Hoist Chain Working Load Limits (T)

Part No.	a d (mm)	吊蓝式结索				穿套式结索		穿套式结索	
		直吊		穿套式结索		直吊		穿套式结索	
		0°-45°	45°-60°	0°-45°	45°-60°	0°-45°	45°-60°		
	L=Loadfactor	L=1.0	L=0.8	L=4.0	L=1.6	L=1.4	L=1.0	L=1.12	L=0.8
WS610060	6.0	1.0	0.8	4.0	1.6	1.4	1.0	1.1	0.8
WS610080	8.0	2.0	1.6	8.0	3.2	2.8	2.0	2.0	1.6
WS610100	10	3.2	2.5	12.5	5.0	4.5	3.2	3.6	2.5
WS610110	11	3.8	3.0	15.2	6.0	5.3	3.8	4.1	3.0
WS610120	12	4.6	3.6	18.4	7.3	6.5	4.6	5.2	3.6
WS610125	12.5	5.0	4.0	20	8.0	7.0	5.0	5.5	4.0
WS610130	13	5.3	4.2	21.2	8.4	7.4	5.3	5.8	4.2
WS610140	14	6.2	5.0	24.8	9.9	8.7	6.2	6.9	5.0
WS610150	15	7.0	5.6	28	11.2	9.8	7.0	7.7	5.6
WS610160	16	8.0	6.4	32	12.8	11.2	8.0	8.8	6.4
WS610180	18	10.0	8.0	40	16.0	14.0	10.0	11.0	8.0
WS610190	19	11.3	9.0	45.2	18	15.8	11.3	12.4	9.0
WS610200	20	12.5	10	50	20	17.5	12.5	13.7	10
WS610220	22	15.0	12.0	60	24.0	21.2	15.0	17.0	12.0
WS610240	24	18.0	14.4	72	28.8	25.2	18.0	20.2	14.4
WS610260	26	21.3	17.0	85.2	34.1	29.8	21.3	23.4	17.0
WS610300	30	28.2	22.6	112.8	45.1	39.5	28.2	31.6	22.6
WS610320	32	32.1	25.6	128.4	51.3	44.9	32.1	35.3	25.6
WS610340	34	36.2	28.9	144.8	57.9	50.7	36.2	40.5	28.9
WS610360	36	40	32	160	64	56	40	44	32
WS610380	38	45.3	36.2	181.1	72.4	63.4	45.3	49.8	36.2
WS610420	42	55.5	44.4	222	88.8	77.7	55.5	61	44.4

LIFTING SLING

WS61 H Oist Chain Working Load Limits (T)

Part No.	d (mm)	a		a		a		a	
		L=Loadfactor	0°-45° L=1.4	45°-60° L=1.0	0°-45° L=2.1	45°-60° L=1.5	0°-45° L=2.1	45°-60° L=1.5	0°-45° L=2.1
WS620060	6		1.5	1.1	2.3	1.6	2.3	1.6	
WS620080	8		2.8	2.0	4.2	3.0	4.2	3.0	
WS620100	10		4.4	3.2	6.7	4.8	6.7	4.8	
WS620110	11		5.3	3.8	7.9	5.7	7.9	5.7	
WS620120	12		6.4	4.6	9.6	6.9	9.6	6.9	
WS620125	12.5		7.0	5.0	10.5	7.5	10.5	7.5	
WS620130	13		7.4	5.3	11.1	7.9	11.1	7.9	
WS620140	14		8.8	6.3	13.2	9.5	13.2	9.5	
WS62150	15		9.8	7.0	14.7	10.5	14.7	10.5	
WS620160	16		11.2	8.0	16.8	12	16.8	12	
WS620180	18		14.0	10.0	21.0	15.0	21.0	15.0	
WS620190	19		15.8	11.3	23.7	16.9	23.7	16.9	
WS620200	20		17.5	12.5	26.2	18.7	26.2	18.7	
WS620220	22		21.3	15.3	32.0	22.9	32.0	22.9	
WS620240	24		25.2	18.0	37.8	27.0	37.8	27.0	
WS620260	26		30.2	21.6	45.3	32.4	45.3	32.4	
WS620300	30		39.5	28.3	59.3	42.4	59.3	42.4	
WS620320	32		44.8	32	67.2	48	67.2	48	
WS620340	34		50.7	36.3	76.1	52.4	76.1	52.4	
WS620360	36		56	40	84	60	84	60	
WS620380	38		63.4	45.3	95.1	67.9	95.1	67.9	
WS620420	42		77.7	55.5	116.5	83.2	116.5	83.2	

LIFTING SLING

Sling Application

Hitches

Every lift uses one of three basic hitches:

1. **Vertical** – The vertical, or straight, attachment is simply using a sling to connect a lifting hook or other device to a load. Full rated load of the sling may be used, but never exceeded. A tagline should be used on such a lift to prevent rotation, which can damage the sling. A wire rope sling with a hand-tucked splice can unlay and fail if the sling is allowed to rotate.

2. **Choker** – Choker Hitch configurations reduce the rated capacity of a sling by 20 to 25 percent. If a load is hanging free, the normal choke angle is approximately 135°. When the choke angle is less than 120°, an adjustment in the choker rated capacity must be made (see illustration below). Extreme care should be taken to determine the choke angle as accurately as possible.

As indicated in the table below, the decrease in rated capacity is dramatic.

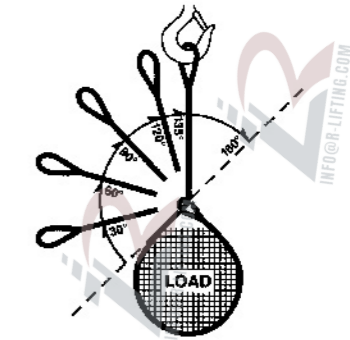
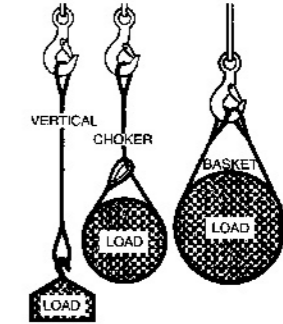

Choker Hitch

RATED CAPACITY ADJUSTMENT

Choke Angle (Degrees)	IWRC and Fiber Core Rope Percent of Choker Rated Capacity
Over 120	100
90 – 120	87
60 – 89	74
30 – 59	62
Up to 29	49

Angle Adjustment

Rated capacity adjustment for slings in choker hitch when angle is less than 120°. Choke angles greater than 135° are unstable and should not be used.

3. **Basket** – Basket hitches distribute a load equally between the two legs of a sling, within limitations imposed by the angles at which legs are rigged to the load (see discussion of sling angles).

Basket Hitch

CAPACITY ADJUSTMENT

Angle (Degrees)	Percent of Single Leg Capacity
90	200
60	170
45	140
30	100

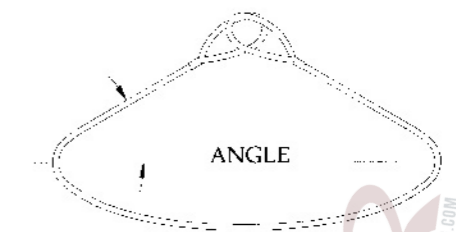

A basket hitch has twice the capacity of a single leg only if legs of sling are vertical. and only if D/d ratio is 25:1 and it is vertical. D/d > 25:1 per ANSI B30.9.

WARNING: Do not use, or allow the use of the products in this catalog, unless the user has read and understands the applicable instructions and product warnings. Information available upon request.

LIFTING SLING

Reeving

Reeving through connections to load increases load on connections fitting by as much as twice.
Do not reeve!

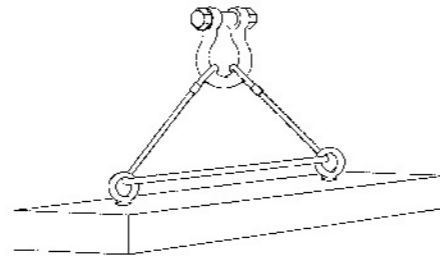

Triple and Quad Leg Slings

Triple leg slings have 50% more capacity than double leg only if the center of gravity is in center of connection points and the legs are adjusted properly (equal share of the load).
Quad leg slings offer improved stability but do not provide increased lifting capacity.

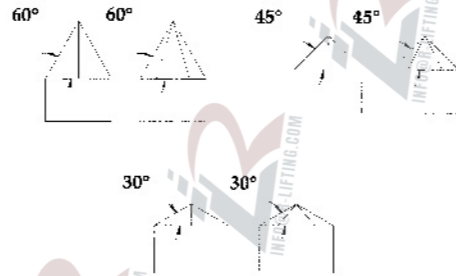

Center Of Gravity (COG)

The location of the center of gravity to the pick points is an important consideration.

COG and Sling Loading

When lifting vertically, the load will be shared equally if the center of gravity is spaced equally between the pick points, as in the first illustration at right. If the weight of the load is 10,000 lbs., then each sling will have a load of 5,000 lbs. and each shackle and eyebolt will also have a load of 5,000 lbs.

When the center of gravity is not equally spaced between the pick points, as in the second illustration, the slings and fittings will not carry an equal share of the load. The sling connected to the pick point closest to the center of gravity will carry the greatest share of the load. Sling 2 is closest to COG. It will have the greatest share of load.

$$\text{Sling 2} = 10,000 \times 8 / (8+2) = 8,000$$

$$\text{Sling 1} = 10,000 \times 2 / (8+2) = 2,000$$

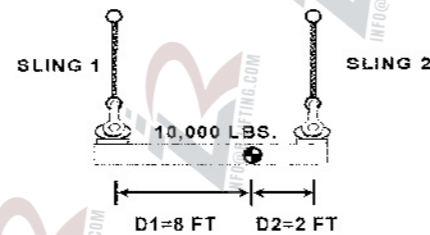
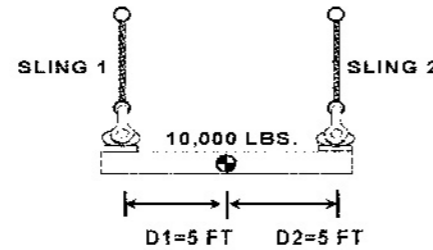

WARNING: Do not use, or allow the use of the products in this catalog, unless the user has read and understands the applicable instructions and product warnings. Information available upon request.

LIFTING SLING

Sling Angle

Sling Angle (also called angle of loading) is the angle measured between a horizontal plane and the sling leg or body. This angle is very important and can have a dramatic effect on the rated capacity of the sling (see illustration below). As illustrated at right, when this angle decreases, the load on each leg increases. This principle applies whether one sling is used to pull at an angle, in a basket hitch, or for multilegged bridle slings. Sling angles of less than 30° shall not be used.

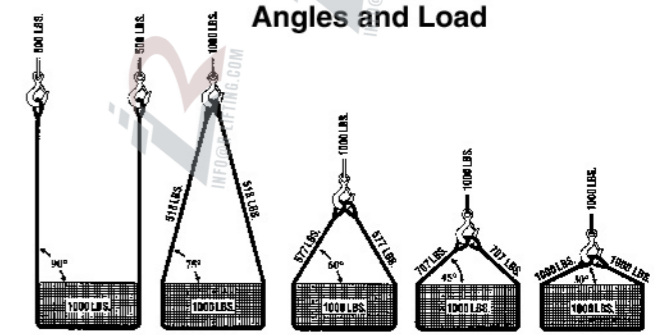

Angles and Stress

How do you carry two buckets of water? These illustrations typify the stresses imposed on slings when the legs are attached to the load at various angles.

Sling Angles

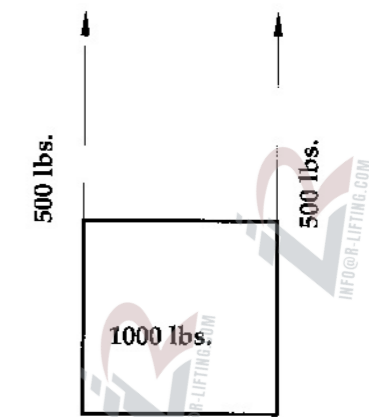

Load in each sling leg = 500 x Load Angle Factor of Angle "A"

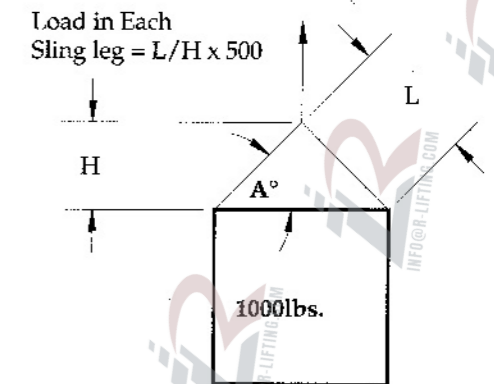
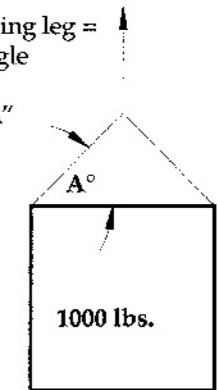

Sling Angle Degrees (A°)	Load Angle Factor = L/H
90	1.00
60	1.155
50	1.305
45	1.414
30	2.00

LOAD ON EACH LEG OF SLING = (Load ÷ 2) x LOAD ANGLE FACTOR

ANSI B30.9 recommends against the use of a horizontal sling angle smaller than 30.°

WARNING: Do not use, or allow the use of the products in this catalog, unless the user has read and understands the applicable instructions and product warnings. Information available upon request.

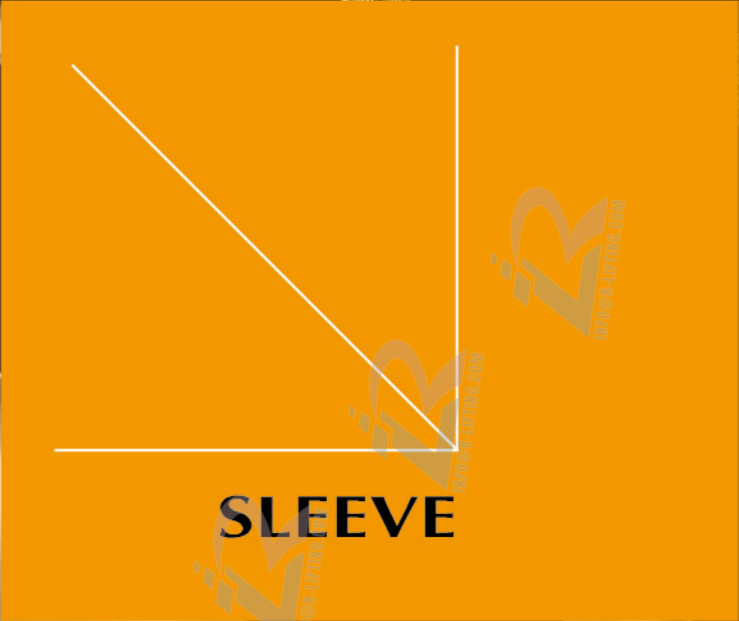

SLEEVE

ALUMINIUM SLEEVE

Aluminium Ferrules

Specification EN 13411-3 (DIN 3093)

H-Quality aluminum ferrules are manufactured per EN13411-3 (DIN 3093) from #1 to #60. For safety in fabrication and application, our ferrules are made of strictly material corresponding to the requirements of EN 13411-3 (DIN 3093) regarding material composition and mechanical properties.



PART NO.	FERRULE CODE.	A (mm)	B (mm)	S (mm)	L (mm)	WEIGHT Kgs/1000Pcs	L' (mm) GB 6946-93
SL990010	1	1.2	2.4	0.65	5	0.098	-
SL990015	1.5	1.7	3.4	0.75	6	0.176	-
SL990020	2	2.2	4.4	0.85	7	0.285	-
SL990025	2.5	2.7	5.4	1.05	9	0.439	-
SL990030	3	3.3	6.6	1.25	11	0.907	-
SL990035	3.5	3.8	7.6	1.5	13	1.18	-
SL990040	4	4.4	8.8	1.7	14	1.63	-
SL990045	4.5	4.9	9.8	1.9	16	2.39	-
SL990050	5	5.5	11.0	2.1	18	3.62	-
SL990060	6	6.6	13.2	2.5	21	5.87	25
SL990065	6.5	7.2	14.4	2.7	23	7.18	-
SL990070	7	7.8	15.6	2.9	25	9.83	30
SL990080	8	8.8	17.6	3.3	28	12.96	34
SL990090	9	9.9	19.8	3.7	32	18.94	38
SL990100	10	10.9	21.8	4.1	35	24.09	42
SL990110	11	12.1	24.2	4.5	39	35.35	47
SL990120	12	13.2	26.4	4.9	42	44.18	50
SL990130	13	14.2	28.4	5.4	46	59.86	55
SL990140	14	15.3	30.6	5.8	49	73.5	59
SL990160	16	17.5	35.0	6.7	56	111	67
SL990180	18	19.6	39.2	7.6	63	156	76
SL990200	20	21.7	43.4	8.4	70	217	84
SL990220	22	24.3	48.6	9.2	77	292	92
SL990240	24	26.4	52.8	10.0	84	376	101
SL990260	26	28.5	57.0	10.9	91	481	109
SL990280	28	31.0	62.0	11.7	98	603	118
SL990300	30	33.1	66.2	12.5	105	739	126
SL990320	32	35.2	70.4	13.4	112	897	134
SL990340	34	37.8	75.6	14.2	119	1077	143
SL990360	36	39.8	79.6	15.0	126	1275	152
SL990380	38	41.9	83.8	15.8	133	1503	160
SL990400	40	44.0	88.0	16.6	140	1734	168
SL990420	42	46.2	92.4	17.5	147	2024	-
SL990440	44	48.4	96.8	18.3	154	2314	184
SL990460	46	50.6	101.2	19.2	161	2662	-
SL990480	48	52.8	105.6	20.0	168	3010	200
SL990500	50	55.0	110.0	20.8	175	3412	-
SL990520	52	57.2	114.4	21.6	182	3813	216
SL990540	54	59.4	118.8	22.5	189	4293	-
SL990560	56	61.6	123.2	23.3	196	4772	232
SL990580	58	63.8	127.6	24.2	203	5326	-
SL990600	60	66.0	132.0	25.0	210	5880	248

*The larger sizes of aluminium ferrules are available on request.

ALUMINIUM SLEEVE

Aluminium Oval Sleeves

H-quality aluminum oval sleeves are extruded from a high quality aluminium alloy, and heat treated for excellent cold forming or swaging qualities. Return eye splice using ALUMINIUM SLEEVES will attain 95% of Improved plow wire rope catalog strength when properly swaged.

CAUTION: Return eye slings using oval aluminium sleeves must be properly swaged to attain strength.

PART NO.	SIZE	A (in)	B (in)	C (in)	D (in)	L (in)	WEIGHT Lbs/100Pcs
SL990104	1/4"	19/64	19/32	17/32	27/32	1	2.3
SL990108	1/8"	5/32	5/16	11/32	1/2	5/8	0.66
SL990316	3/16"	7/32	7/16	7/16	21/32	1	1.65
SL990516	5/16"	3/8	3/4	21/32	1 1/32	1 17/84	4.3
SL990308	3/8"	7/16	27/32	3/4	1 5/32	1 3/8	5.3
SL990716	7/16"	1/2	1	29/32	1 13/32	1 23/32	11
SL990102	1/2"	19/32	1 11/64	1 1/32	1 5/8	1 15/16	16.5
SL990916	9/16"	23/32	1 3/8	1 7/32	1 57/64	2 7/32	22
SL990508	5/8"	3/4	1 1/2	1 3/8	2 3/32	2 1/2	32
SL990304	3/4"	53/64	1 11/16	1 1/2	2 3/8	2 7/8	52
SL990708	7/8"	61/64	1 7/8	1 11/16	2 5/8	3	67
SL991000	1"	1 3/32	2 7/32	1 31/32	3 3/32	3 3/4	125
SL991108	1 1/8"	1 9/32	2 9/16	2 5/16	3 19/32	4 9/32	172
SL991104	1 1/4"	1 13/32	2 25/32	2 1/2	3 7/8	4 7/16	214
SL991102	1 1/2"	1 21/32	3 19/64	3 1/8	4 3/4	5 35/64	390

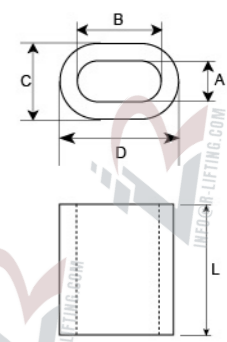

Aluminium Hourglass Sleeves

PART NO.	SIZE		A		B		C		D		L		WEIGHT Kgs/1000 Pcs
	in	mm	in	mm	in	mm	in	mm	in	mm	in	mm	
SL980364	3/64	1.19	1/16	1.59	1/8	3.18	9/64	3.6	13/64	5.2	3/8	9.5	0.276
SL980116	1/16	1.58	5/64	1.98	5/32	3.97	11/64	4.4	1/4	6.4	3/8	9.5	0.433
SL980564	5/64	1.98	3/32	2.38	3/16	4.76	13/64	5.2	5/16	7.9	3/8	9.5	0.645
SL980332	3/32	2.38	1/8	3.18	1/4	6.35	9/32	7.1	13/32	10.3	1/2	12.7	1.45
SL980108	1/8	3.18	5/32	3.97	5/16	7.94	11/32	8.7	1/2	12.7	5/8	15.8	2.70
SL980532	5/32	3.97	3/16	4.76	3/8	9.53	3/8	9.53	9/16	14.3	11/16	17.4	3.67
SL980316	3/16	4.76	7/32	5.56	7/16	11.11	7/16	11.11	21/32	16.7	1	25.4	7.18
SL980732	7/32	5.56	1/4	6.35	1/2	12.70	1/2	12.7	3/4	19	1-1/16	26.9	10.00
SL980104	1/4	6.35	9/32	7.14	9/16	14.29	17/32	13.5	13/16	20.6	1-1/8	28.5	11.76
SL980932	9/32	7.14	5/16	7.94	5/8	15.88	9/16	14.3	7/8	22.2	1-3/16	30.1	13.62
SL980516	5/16	7.94	3/8	9.53	23/32	19.05	11/16	17.5	1-1/32	26.2	1-1/4	31.7	20.94
SL980308	3/8	9.53	7/16	11.11	27/32	22.23	3/4	19.1	1-5/32	29.4	1-7/16	36.5	28.18
SL980716	7/16	11.11	1/2	12.7	1	25.40	15/16	23.8	1-7/16	36.5	1-11/16	42.8	52.00
SL980102	1/2	12.7	9/16	14.29	1-1/8	28.58	1-1/16	27	1-5/8	41.3	2	50.8	80.15
SL980916	9/16	14.29	5/8	15.88	1-1/4	31.75	1-1/8	28.6	1-3/4	44.5	2-1/8	53.9	99.88
SL980508	5/8	15.88	11/16	17.46	1-3/8	34.93	1-1/4	31.8	1-15/16	49.2	2-1/2	63.5	139.78

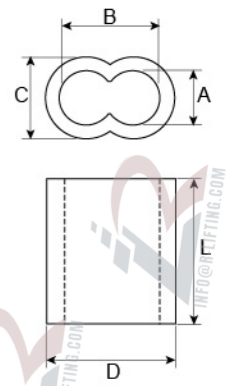

*The larger sizes of sleeves are available on request.

ALUMINIUM SLEEVE

Aluminium Stop Buttons

PART NO.	SIZE	A(mm) Inner Dia.	D(mm) Outer Dia.	L(mm) Length	WEIGHT Kgs/1000Pcs
SL970364	3/64"	1.54	4.40	4.16	0.236
SL970116	1/16"	1.92	6.35	4.16	0.278
SL970564	5/64"	2.38	6.35	4.16	0.282
SL970332	3/32"	2.90	8.72	7.95	1.05
SL970108	1/8"	3.86	8.72	7.95	0.949
SL970532	5/32"	4.70	11.11	8.73	1.76
SL970316	3/16"	5.54	11.11	8.73	1.69
SL970732	7/32"	6.35	11.11	8.73	1.50
SL970104	1/4"	7.20	17.46	17.46	9.07
SL970516	5/16"	9.53	17.46	17.46	7.46
SL970308	3/8"	11.13	17.46	17.46	6.58
SL970102	1/2"	14.28	26.98	26.98	30.32
SL970916	9/16"	15.88	28.60	31.75	38.52
SL970508	5/8"	17.46	31.75	31.75	47.88

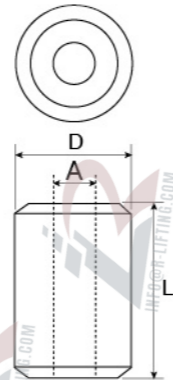

Aluminium Ferrules JIS Type

PART NO.	FERRULE CODE.	A (mm)	B (mm)	C (mm)	D (mm)	L (mm)	WEIGHT Kgs/1000Pcs
SL960060	6	7.00	13.80	3.20	3.80	24	10
SL960070	7	8.20	16.20	3.60	4.25	26	14
SL960080	8	9.40	18.60	4.00	4.70	32	22
SL960090	9	10.22	20.70	4.30	5.52	36	29
SL960100	10	11.60	23.00	4.50	5.50	40	37
SL960120	12	13.62	27.60	5.30	6.92	48	63
SL960140	14	15.89	32.20	5.53	7.42	56	88
SL960160	16	18.16	36.80	6.32	8.48	64	130
SL960180	18	20.43	41.40	7.11	9.54	72	186
SL960200	20	23.10	46.00	7.70	9.20	80	245
SL960220	22	25.40	50.60	8.30	10.00	88	319
SL960240	24	27.80	55.30	8.90	10.90	96	408
SL960260	26	29.90	59.80	10.70	12.90	104	581
SL960280	28	32.20	64.40	11.30	13.60	112	714
SL960300	30	34.50	69.00	11.80	14.30	120	859
SL960320	32	36.80	73.60	12.50	15.20	128	1026

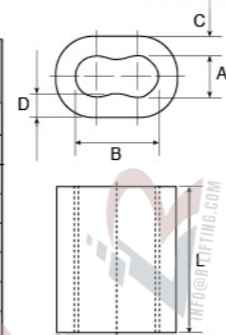

ALUMINIUM & COPPER SLEEVE

Aluminium Ferrules Form C

PART NO.	FERRULE CODE.	L1 (mm)	L2 (mm)
SL950080	8	43	34
SL950090	9	48	38.5
SL950100	10	53	42
SL950110	11	59	46.7
SL950120	12	65	50.2
SL950130	13	70	54.7
SL950140	14	75	58.2
SL950160	16	85	66.5
SL950180	18	96	75
SL950200	20	106	83
SL950220	22	116	91
SL950240	24	126	99.5
SL950260	26	136	107.2
SL950280	28	147	115.5
SL950300	30	158	125
SL950320	32	170	135
SL950360	36	190	150
SL950380	38	200	158
SL950440	44	235	186
SL950520	52	276	218

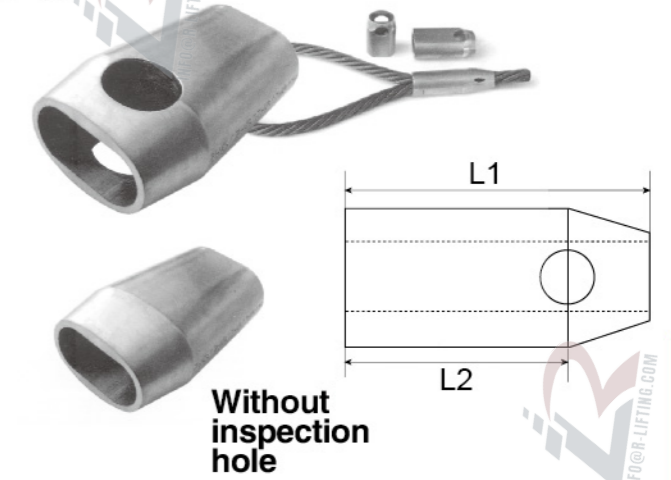

Without inspection hole
The inspection hole guarantees control of the correct inserted length of wire rope before and after swaging. These types of sleeves have to be swaged with the conical type C swaging dies.

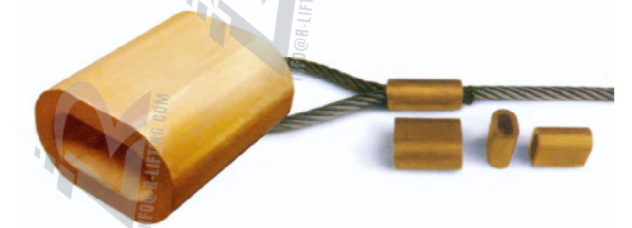

Copper Ferrules

PART NO.	FERRULE CODE.	A (mm)	B (mm)	S (mm)	L (mm)	WEIGHT kgs/1000pcs
SL890010	1	1.3	2.6	0.85	5	0.32
SL890015	1.5	1.8	3.6	1.05	6	0.72
SL890020	2	2.4	4.8	0.85	7	0.82
SL890025	2.5	2.7	5.4	1.10	9	1.70
SL890030	3	3.3	6.6	1.35	11	2.90
SL890035	3.5	3.9	7.8	1.60	13	4.50
SL890040	4	4.3	8.8	1.70	14	6.20
SL890045	4.5	5.1	10.2	1.90	16	8.90
SL890050	5	5.6	11.2	2.10	18	12.20
SL890060	6	6.7	13.4	2.50	21	20.00
SL890065	6.5	6.9	14.0	2.70	23	27.00
SL890070	7	7.5	15.0	3.00	25	32.00
SL890080	8	8.5	17.0	3.50	28	47.00
SL890090	9	9.9	19.8	3.70	32	68.00
SL890100	10	10.9	21.8	4.10	35	90.00
SL890110	11	11.6	23.2	4.20	39	122.00
SL890120	12	13.2	26.4	4.90	42	158.00
SL890130	13	14.2	28.4	5.40	46	198.00
SL890140	14	15.3	30.6	5.80	49	243.00
SL890160	16	17.5	35.0	6.70	56	366.00
SL890180	18	19.0	38.0	7.80	63	529.00

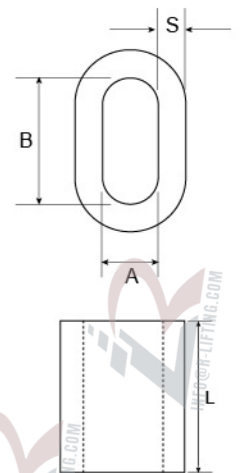

Zinc Plated, Nickel Plated & Chrome Plated are available on request

COPPER SLEEVE

Copper Hourglass Sleeves

H-Quality extruded copper hourglass sleeves and stop buttons have efficient cold forming properties, and are ideal for non-rusting permanent splices. These sleeves and buttons are 99% pure copper, and the mass of copper provides excellent holding strength.

Return eye splice using copper hourglass sleeves will attain 95% of Improved Plow wire rope catalog strength when properly swaged.

CAUTION: Return eye slings using copper hourglass sleeves must be properly swaged to attain strength.

PART NO.	SIZE	A	B	C	D	L	WEIGHT Kgs/1000Pcs
SL880364	3/64"	1/16	1/8	9/64	13/64	3/8	1.0
SL880116	1/16"	3/32	11/64	11/64	1/4	25/64	1.4
SL880564	5/64"	3/32	3/16	7/32	5/16	27/64	2.5
SL880332	3/32"	7/64	1/4	15/64	3/8	29/64	4.0
SL880108	1/8"	9/64	21/64	9/32	1/2	9/16	8.0
SL880532	5/32"	3/16	27/64	3/8	19/32	5/8	12.3
SL880316	3/16"	7/32	7/16	7/16	43/64	7/8	25
SL880732	7/32"	1/4	33/64	15/32	23/32	7/8	32
SL880104	1/4"	9/32	19/32	17/32	27/32	1 1/8	36
SL880516	5/16"	3/8	23/32	21/32	1 1/64	1 1/8	64
SL880308	3/8"	7/16	13/16	23/32	1 1/8	1 1/2	89
SL880102	1/2"	19/32	1 7/64	31/32	1 15/32	1 7/8	270

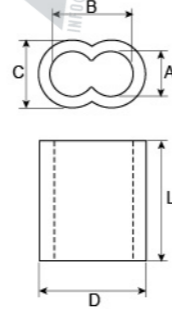

Copper Button Stops

PART NO.	SIZE	A	D	L	WEIGHT Kgs/1000Pcs
SL870364	3/64"	1/16	11/64	7/32	0.67
SL870116	1/16"	5/64	13/64	7/32	0.96
SL870332	3/32"	7/64	21/64	21/64	3.9
SL870108	1/8"	5/32	21/64	21/64	3.3
SL870532	5/32"	3/16	27/64	21/64	6.5
SL870316	3/16"	7/32	27/64	21/64	6.2
SL870732	7/32"	1/4	27/64	5/8	6.0
SL870104	1/4"	9/32	21/32	11/16	32
SL870516	5/16"	3/8	21/32	11/16	29

Zinc Plated, Nickel Plated & Chrome Plated are available on request

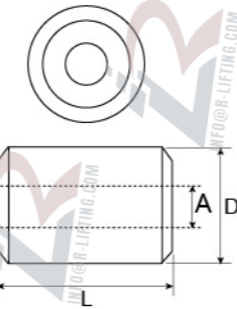

STEEL SLEEVE

Flemish Eye Steel Swaging Sleeves(S-505)

Our modern in-house forging, heat treatment, sand blasting, auto-marking facilities assures the consistent quality of Flemish eye steel sleeves from 1/4" to 6" (galvanized and self-colored)

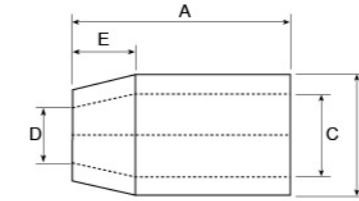

PART NO.	FOR WIRE ROPE SIZE (inch)	DIMENSION (inch)					MAX.AFTER SWAGE DIMENSIONS (inch)	WEIGHT Kgs/100Pcs
		A	B	D	E	C		
SL700104	1/4"	1	0.66	0.31	0.28	0.47	0.57	2.27
SL700516	5/16"	1.5	0.91	0.38	0.44	0.62	0.75	6.36
SL700308	3/8"	1.5	0.91	0.47	0.39	0.66	0.75	6.36
SL700716	7/16"	2	1.22	0.53	0.65	0.85	1.01	15
SL700102	1/2"	2	1.22	0.63	0.56	0.91	1.01	13
SL700916	9/16"	2.75	1.47	0.7	0.63	1.03	1.24	29
SL700508	5/8"	2.75	1.47	0.75	0.63	1.09	1.24	26
SL700304	3/4"	3.19	1.72	0.91	0.84	1.28	1.46	40
SL700708	7/8"	3.56	2.03	1.03	1	1.53	1.68	60
SL701000	1"	4	2.28	1.16	1.13	1.72	1.93	89
SL701108	1-1/8"	4.8	2.5	1.28	1.25	1.94	2.13	118
SL701104	1-1/4"	5.19	2.78	1.44	1.41	2.16	2.32	161
SL701308	1-3/8"	5.81	3	1.56	1.56	2.38	2.52	192
SL701102	1-1/2"	6.25	3.25	1.69	1.69	2.63	2.71	227
SL701304	1-3/4"	7.25	3.84	1.94	1.97	3.13	3.1	366
SL702000	2"	8.5	4.38	2.25	2.25	3.63	3.56	514
SL702104	2-1/4"	9.56	5.03	2.5	2.53	4.03	4.12	879
SL702102	2-1/2"	10.5	5.5	2.75	2.81	4.50	4.5	1068
SL702304	2-3/4"	11.5	5.75	3	3.09	4.75	4.7	1271
SL703000	3"	12	6	3.25	3.38	5	4.96	1335
SL703104	3-1/4"	13	6.5	3.86	3.54	5.43	5.37	1650
SL703102	3-1/2"	14	7	3.88	3.94	5.84	5.77	2106
SL703304	3-3/4"	15	7.5	4.06	4.25	6.31	6.23	2497
SL704000	4"	16	8.13	4.38	4.50	6.81	6.69	3087
SL704102	4-1/2"	18	9.13	4.88	5.06	7.66	7.45	4540
SL705000	5"	20	10.52	5.5	5.63	8.73	8.28	6600
SL706000	6"	24	12.54	6.5	6.75	10.2	9.93	12300

⚠ Recommended to be used with 6x19, 6x25, 6x29, 6x37 IPS or XIP(EIP), FC or IWRC wire rope. If using with any other type of construction or grade of wire rope, it is recommended to make the breaking load test of the swaged termination to prove the adequacy of the assembly to be manufactured.

STEEL SLEEVE

Steel Oval Sleeves

Specially processed low carbon steel

Note: Steel Oval Sleeves are recommended for use with 6x19 or 6x37, IPS ORxIP(EIP), RRL,FC or IWRC wire rope

PART NO.	ROPE SIZE (inch)	L(in)	B(in)	C(in)	D(in)	MAX.AFTER SWAGE DIA. (inch)	WEIGHT Lbs/ 100Pcs
SL790516	5/16	1.25	1.08	0.81	0.19	0.77	17
SL790308	3/8	1.25	1.12	0.81	0.14	0.77	13
SL790716	7/16	1.63	1.41	1.02	0.19	1.03	31
SL790102	1/2	1.63	1.44	1.02	0.16	1.03	27
SL790916	9/16	2.25	1.72	1.23	0.23	1.29	63
SL790508	5/8	2.25	1.84	1.28	0.20	1.29	54
SL790304	3/4	2.63	2.16	1.52	0.23	1.55	90
SL790708	7/8	2.88	2.50	1.75	0.27	1.80	126
SL791000	1	3.06	2.84	2.00	0.33	2.05	187
SL791104	1-1/4	4.06	3.50	2.50	0.38	2.56	384

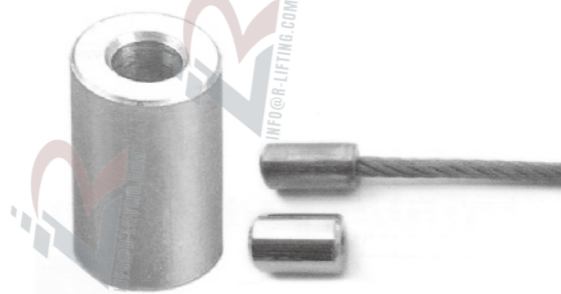
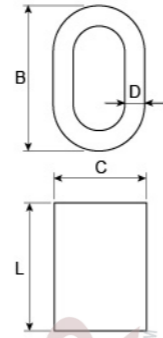

Steel Stop Buttons

Specially processed low carbon steel

PART NO.	ROPE SIZE (inch)	A(in)	D(in)	L(in)	MAX.AFTER SWAGE DIA. (inch)	WEIGHT Lbs/ 100Pcs
SL770108	1/8	0.14	0.44	0.50	0.40	2
SL770316	3/16	0.20	0.56	0.70	0.52	4
SL770104	1/4	0.30	0.63	1.06	0.58	8
SL770516	5/16	0.36	0.88	1.13	0.77	16
SL770308	3/8	0.42	0.88	1.48	0.77	15
SL770716	7/16	0.48	1.13	1.63	1.03	30
SL770102	1/2	0.55	1.31	1.89	1.16	50
SL770916	9/16	0.61	1.44	2.02	1.29	70
SL770508	5/8	0.67	1.56	2.42	1.42	100
SL770304	3/4	0.79	1.69	2.73	1.55	131
SL770708	7/8	0.94	2.00	3.27	1.80	220
SL771000	1	1.06	2.25	3.67	2.05	310
SL771108	1-1/8	1.19	2.56	4.05	2.30	450
SL771104	1-1/4	1.33	2.81	4.58	2.56	650

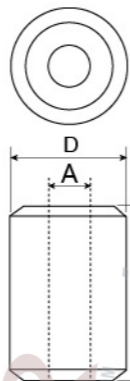

Recommended to be used with 6x19, 6x25, 6x29, 6x37 IPS or XIP(EIP), FC or IWRC wire rope. If using with any other type of construction or grade of wire rope, it is recommended to make the breaking load test of the swaged termination to prove the adequacy of the assembly to be manufactured.

STEEL SLEEVE

Forged open swage terminals

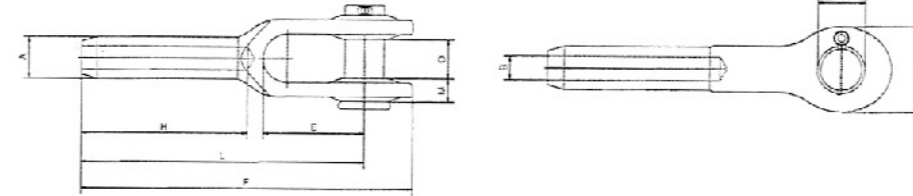

PART NO.	ROPE SIZE (inch)	Dimensions(mm)										Weight each approx. Kg
		A	B	D	E	F	H	L	M	O	Y	
SL740104	1/4	12.6	6.9	17.5	38.1	120.7	54.0	101.6	7.9	17.5	34.9	0.3
SL740516	5/16	19.6	8.6	20.6	44.5	158.8	81.0	134.9	10.3	20.6	41.3	0.6
SL740308	3/8	19.6	10.3	20.6	44.5	158.8	81.0	134.9	10.3	20.6	41.3	0.5
SL740716	7/16	24.9	12.3	25.4	50.8	198.4	108.0	169.9	12.7	25.4	50.8	1.1
SL740102	1/2	24.9	13.9	25.4	50.8	198.4	108.0	169.9	12.7	25.4	50.8	1.1
SL740916	9/16	31.9	15.5	30.2	57.2	242.9	134.9	206.4	15.9	31.8	63.5	2.2
SL740508	5/8	31.9	17.1	30.2	57.2	242.9	134.9	206.4	15.9	31.8	63.5	2
SL740304	3/4	39.2	20.2	35.1	69.9	296.9	161.9	254.0	19.1	38.1	76.2	3.5
SL740708	7/8	43.2	23.8	41.4	82.6	346.1	188.9	295.3	23.8	44.5	85.7	5.4
SL741000	1	50.2	27.0	50.8	95.3	396.9	215.9	339.7	26.2	50.8	101.6	8.1
SL741108	1-1/8	57.0	30.2	57.2	108.0	444.5	242.9	381.0	30.2	57.2	114.3	13.1
SL741104	1-1/4	64.1	33.7	63.5	120.7	493.7	269.9	419.1	30.2	63.5	127.0	16.4
SL741308	1-3/8	71.1	36.9	63.5	133.4	539.8	296.9	460.4	33.3	63.5	133.4	21.6
SL741102	1-1/2	78.1	40.1	69.9	146.1	590.6	323.9	501.7	36.5	76.2	146.1	29.2
SL741304	1-3/4	86.0	47.2	88.9	171.5	689.0	377.8	584.2	42.9	88.9	177.8	42.4
SL742000	2	99.9	53.6	95.3	203.2	798.5	431.8	679.5	46.0	101.6	203.2	67.1
SL742104	2-1/4	113.0	59.9	108.0	171.5	835.0	485.8	704.9	65.1	114.3	222.3	78.5
SL742102	2-1/2	125.2	67.5	108.0	171.5	879.5	498.5	749.3	65.1	114.3	222.3	105.7
SL743000	3	151.4	80.4	133.4	219.1	1044.6	603.3	904.9	76.2	146.1	241.3	173.3



Wire rope terminations will not be adversely affected by temperatures between -40°C -150°C.

Swage terminals properly applied have an efficiency rating of more than 90% according to EN 13411-8.

Material:

Forged from special C-1035 steel, fine grain, special bar quality.

Spheroidized annealed for cold swaging.

Applicable rope type and grade:

The tested class is 8*19, fill factor 0.74, rope grade 2160.

The tested class is 6*36(IWRC), fill factor 0.59, rope grade 2160.

Swage terminals are also recommend for use on 6*19 or 6*37 IWRC regular lay ropes.

They are not recommended for use on fiber core or lang lay ropes.

NOTE!

Due to the variety of steel wire ropes, it is difficult to approve all of them. Verifying tests must be performed in order to verify the strength of application. Steel wire rope with a fiber core has not been tested. Contact our Technical Department for more advice.

STEEL SLEEVE

Forged closed swage terminals

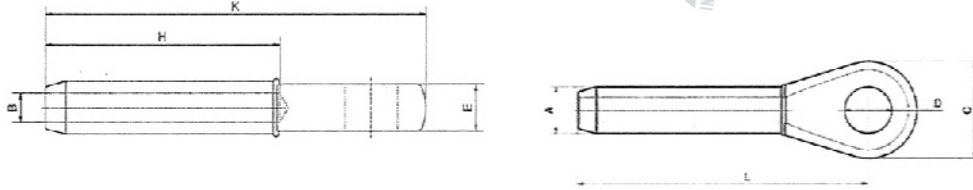

PART NO.	ROPE SIZE (inch)	Dimensions(mm)								Weight each approx. Kg
		A	B	C	D	E	H	K	L	
SL730104	1/4	12.6	6.9	38.1	19.1	12.7	54.0	111.1	88.9	0.2
SL730516	5/16	19.6	8.6	42.9	22.2	17.5	81.0	139.7	114.3	0.3
SL730308	3/8	19.6	10.3	42.9	22.2	17.5	81.0	139.7	114.3	0.3
SL730716	7/16	24.9	12.3	50.8	27.0	22.2	108.0	176.2	146.1	0.7
SL730102	1/2	24.9	13.9	50.8	27.0	22.4	108.0	176.2	146.1	0.6
SL730916	9/16	31.9	15.5	63.5	31.8	28.6	134.9	222.3	184.2	1.3
SL730508	5/8	31.9	17.1	63.5	31.8	28.6	134.9	222.3	184.2	1.3
SL730304	3/4	39.2	20.2	76.2	36.5	33.3	161.9	263.5	219.1	2.3
SL730708	7/8	43.2	23.8	88.9	42.9	38.1	188.9	308.0	257.2	3.4
SL731000	1	50.2	27.0	101.6	52.4	44.5	215.9	349.3	292.1	5.1
SL731108	1-1/8	57.0	30.2	114.3	58.8	50.8	242.9	387.4	323.9	7.3
SL731104	1-1/4	64.1	33.7	127.0	65.1	57.2	269.9	438.2	365.1	10.3
SL731308	1-3/8	71.1	36.9	133.4	65.1	57.2	296.9	479.4	400.1	13.2
SL731102	1-1/2	78.1	40.1	139.7	71.5	63.5	323.9	517.5	431.8	17
SL731304	1-3/4	86.0	47.2	171.5	90.5	76.2	377.8	609.6	508.0	25.3
SL732000	2	99.9	53.6	196.9	96.9	82.6	431.8	698.5	584.2	40.8
SL732104	2-1/4	113.0	59.9	219.1	109.5	101.6	485.8	755.7	631.8	56.7
SL732102	2-1/2	125.2	67.5	219.1	109.5	101.6	498.5	790.6	666.8	64.4
SL733000	3	151.4	80.4	235.0	134.9	136.5	603.3	958.9	816.0	114.3



STEEL SLEEVE

- * Forged Steel Sockets thru 1 1/2" , cast alloy steel 1-5/8" thru 4"
 - * Spelter socket terminations have an efficiency rating of 100%,based on the catalog strength of wire rope.
- Ratings are based on recommended use with 6x7, 6x19 or 6x37, IPS OR XIP, XXIP(EIP), RRL, FC, OR IWRC wire rope.

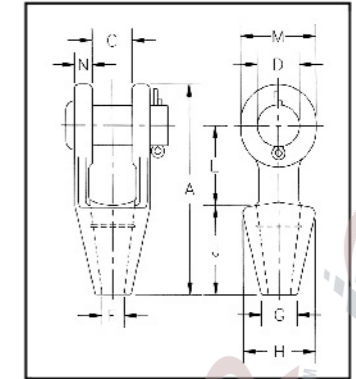

Grooved Open Spelter Sockets

Open Grooved Sockets meet the performance requirements of Federal Specification RR-S-550D, Type A, except for those provisions required of the contractor.

Note: Above drawing illustrates one groove used on sockets 1/4" thru 3/4" Size 7/8" thru 1 1/2" use 2 grooves, Sizes 1 5/8" and larger use 3 grooves.

Wire rope terminations will not be adversely affected by temperatures between -40°C -150°C.
Swage terminals properly applied have an efficiency rating of more than 90% according to EN 13411-8.
This rating is based on the catalogue strength of wire rope.

Material:

Forged from special C-1035 steel, fine grain, special bar quality.
Spheroidized annealed for cold swaging.

Applicable rope type and grade:

The tested class is 8*19, fill factor 0.74, rope grade 2160.

The tested class is 6*36(IWRC), fill factor 0.59, rope grade 2160.

Swage terminals are also recommend for use on 6*19 or 6*37 IWRC regular lay ropes.

They are not recommended for use on fiber core or lang lay ropes.

NOTE!

Due to the variety of steel wire ropes, it is difficult to approve all of them. Verifying tests must be performed in order to verify the strength of application. Steel wire rope with a fiber core has not been tested. Contact our Technical Department for more advice.

PART NO.	ROPE SIZE (inch)	WEIGHT Lbs/Pcs	Dimensione (in.)									
			A	C	D	F	G	H	J	L	M	N
SL720104	1/4	1.10	4.56	0.75	0.69	0.38	0.69	1.56	2.25	1.56	1.31	0.31
SL720516	5/16-3/8	1.30	4.84	0.81	0.81	0.50	0.81	1.69	2.25	1.75	1.50	0.44
SL720716	7/16-1/2	2.25	5.56	1.00	1.00	0.56	0.94	1.88	2.50	2.00	1.88	0.50
SL720916	9/16-5/8	3.60	6.75	1.25	1.19	0.69	1.13	2.25	3.00	2.50	2.25	0.56
SL720304	3/4	5.83	7.94	1.50	1.38	0.81	1.25	2.62	3.50	3.00	2.62	0.62
SL720708	7/8	9.65	9.25	1.75	1.63	0.94	1.50	3.25	4.00	3.50	3.13	0.80
SL721000	1	15.50	10.56	2.00	2.00	1.13	1.75	3.75	4.50	4.00	3.75	0.88
SL721108	1 1/8	21.50	11.81	2.25	2.25	1.25	2.00	4.12	5.00	4.62	4.12	1.00
SL721104	1 1/4-1 3/8	31.00	13.19	2.50	2.50	1.50	2.25	4.75	5.50	5.00	4.75	1.13
SL721102	1 1/2	47.25	15.12	3.00	2.75	1.63	2.75	5.25	6.00	6.00	5.38	1.19
SL721508	1 5/8	55.00	16.25	3.00	3.00	1.75	3.00	5.50	6.50	6.50	5.75	1.31
SL721304	1 3/4-1 7/8	82.00	18.25	3.50	3.50	2.00	3.13	6.38	7.50	7.00	6.50	1.56
SL722000	2-2 1/8	129.00	21.50	4.00	3.75	2.25	3.75	7.38	8.50	9.00	7.00	1.81
SL722104	2 1/4-2 3/8	167.00	23.50	4.50	4.25	2.50	4.00	8.25	9.00	10.00	7.75	2.13
SL722102	2 1/2-2 5/8	252.00	25.50	5.00	4.75	2.88	4.50	9.25	9.75	10.75	8.50	2.38
SL722304	2 3/4-2 7/8	315.00	27.25	5.25	5.00	3.12	4.88	10.50	11.00	11.00	9.00	2.88
SL723000	3-3 1/8	380.00	29.00	5.75	5.25	3.38	5.25	11.12	12.00	11.25	9.50	3.00
SL723104	3 1/4-3 3/8	434.00	30.88	6.25	5.50	3.62	5.75	11.88	13.00	11.75	10.00	3.12
SL723102	3 1/2-3 5/8	563.00	33.25	6.75	6.00	3.88	6.50	12.38	14.00	12.50	10.75	3.25
SL723304	3 3/4-4	783.00	36.25	7.50	7.00	4.25	7.25	13.62	15.00	13.50	12.50	3.50

STEEL SLEEVE

- * Forged Steel Sockets thru 1 1/2" , cast alloy steel 1-5/8" thru 4"
- * Spelter socket terminations have an efficiency rating of 100%, based on the catalog strength of wire rope. Ratings are based on recommended use with 6x7, 6x19 or 6x37, IPS OR XIP, XXIP(EIP), RRL, FC, OR IWRC wire rope.

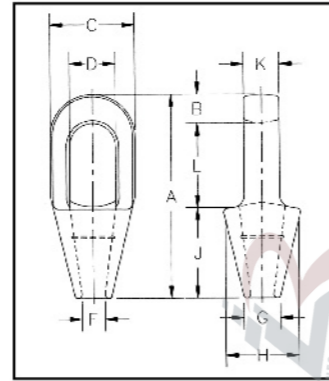

Note: Above drawing illustrates one groove used on sockets 1/4" thru 3/4" Size 7/8" thru 1 1/2" use 2 grooves, Sizes 1 5/8" and larger use 3 grooves.

Grooved Closed Spelter Sockets

Closed Grooved Sockets meet the performance requirements of Federal Specification RR-S-550D, Type B, except for those provisions required of the contractor.

PART NO.	ROPE SIZE (inch)	WEIGHT Lbs/ Pcs	Dimensione (in.)									
			A	B	C	D	F	G	H	J	K	L
SL710104	1/4	0.50	4.50	0.50	1.50	0.88	0.38	0.69	1.56	2.25	0.50	1.75
SL710516	5/16-3/8	0.75	4.88	0.62	1.69	0.97	0.50	0.81	1.69	2.25	0.69	2.00
SL710716	7/16-1/2	1.50	5.44	0.69	2.00	1.16	0.56	0.94	1.88	2.50	0.88	2.25
SL710916	9/16-5/8	2.50	6.31	0.81	2.63	1.41	0.69	1.12	2.38	3.00	1.00	2.50
SL710304	3/4	4.25	7.56	1.06	3.00	1.66	0.81	1.25	2.75	3.56	1.25	3.00
SL710708	7/8	7.25	8.75	1.25	3.63	1.88	0.94	1.50	3.25	4.00	1.50	3.50
SL711000	1	10.50	9.88	1.38	4.13	2.30	1.13	1.75	3.75	4.44	1.75	4.00
SL711108	1 1/8	14.25	11.00	1.50	4.50	2.56	1.25	2.00	4.13	5.00	2.00	4.50
SL711104	1 1/4-1 3/8	19.75	12.12	1.63	5.30	2.81	1.50	2.25	4.75	5.50	2.25	5.00
SL711102	1 1/2	29.20	13.94	1.94	5.33	3.19	1.63	2.75	5.25	6.00	2.50	6.00
SL711508	1 5/8	36.00	15.13	2.13	5.75	3.25	1.75	3.00	5.50	6.50	2.75	6.50
SL711304	1 3/4-1 7/8	57.25	17.25	2.19	6.75	3.75	2.00	3.13	6.38	7.50	3.00	7.56
SL712000	2-2 1/8	79.00	19.50	2.44	7.63	4.38	2.25	3.75	7.38	8.50	3.25	8.56
SL712104	2 1/4-2 3/8	105.00	21.13	2.63	8.50	5.00	2.50	4.00	8.25	9.00	3.63	9.50
SL712102	2 1/2-2 5/8	140.00	23.50	3.12	9.50	5.50	2.88	4.50	9.25	9.75	4.00	10.62
SL712304	2 3/4-2 7/8	220.00	25.38	3.12	10.75	6.25	3.12	4.88	10.19	11.00	4.88	11.25
SL713000	3-3 1/8	276.00	27.00	3.25	11.50	6.75	3.38	5.25	11.50	12.00	5.25	11.75
SL713104	3 1/4-3 3/8	313.00	29.25	4.00	12.25	7.25	3.62	5.75	12.25	13.00	5.75	12.25
SL713102	3 1/2-3 5/8	400.00	31.00	4.00	13.00	7.75	3.88	6.50	13.00	14.00	6.25	13.00
SL713304	3 3/4-4	542.00	33.25	4.25	14.25	8.50	4.25	7.25	14.25	15.00	7.00	14.00

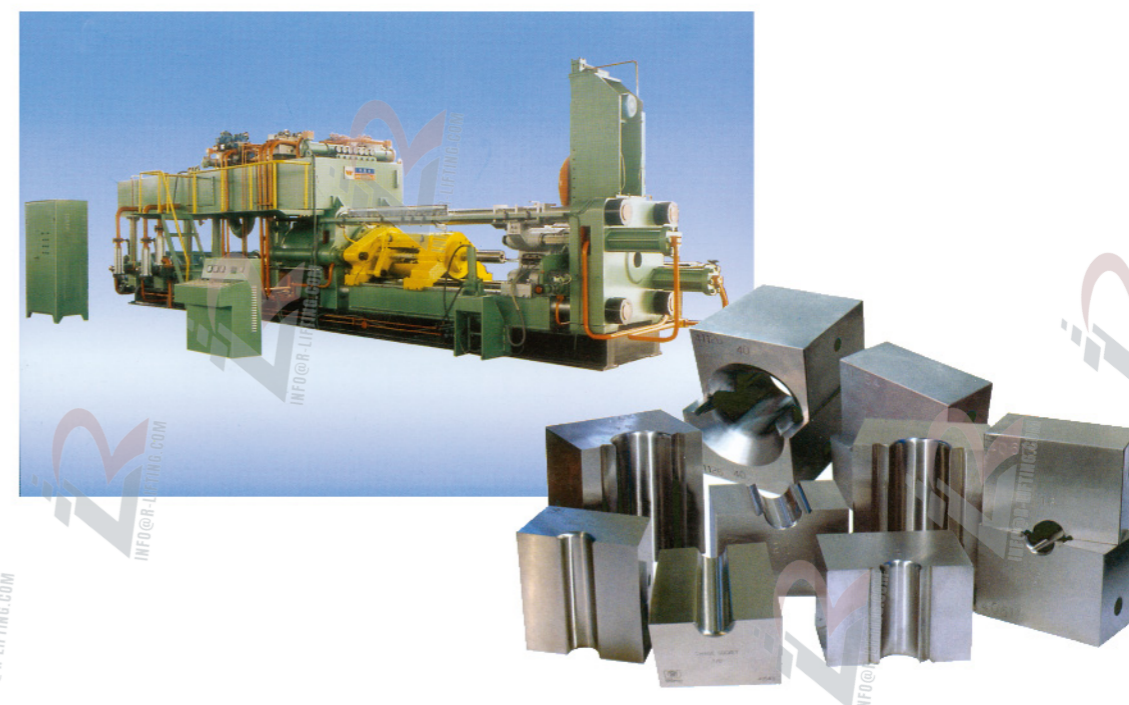
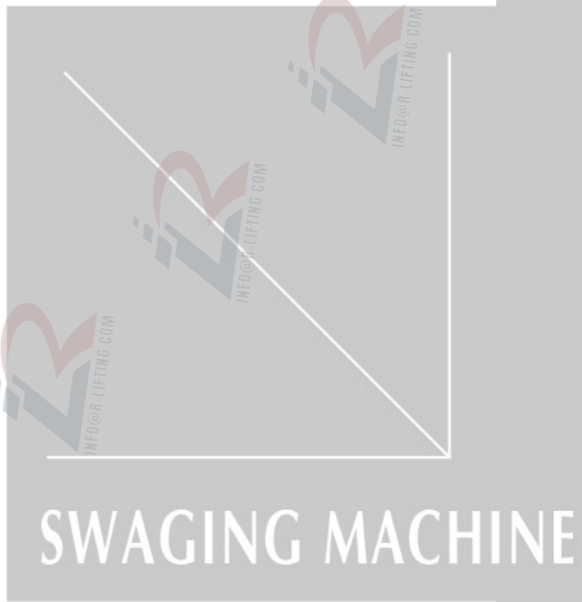
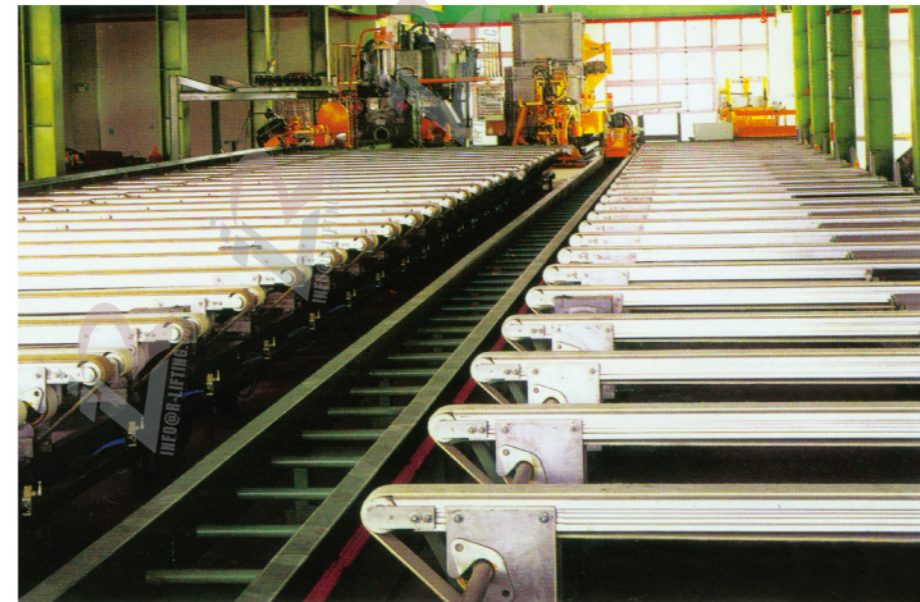
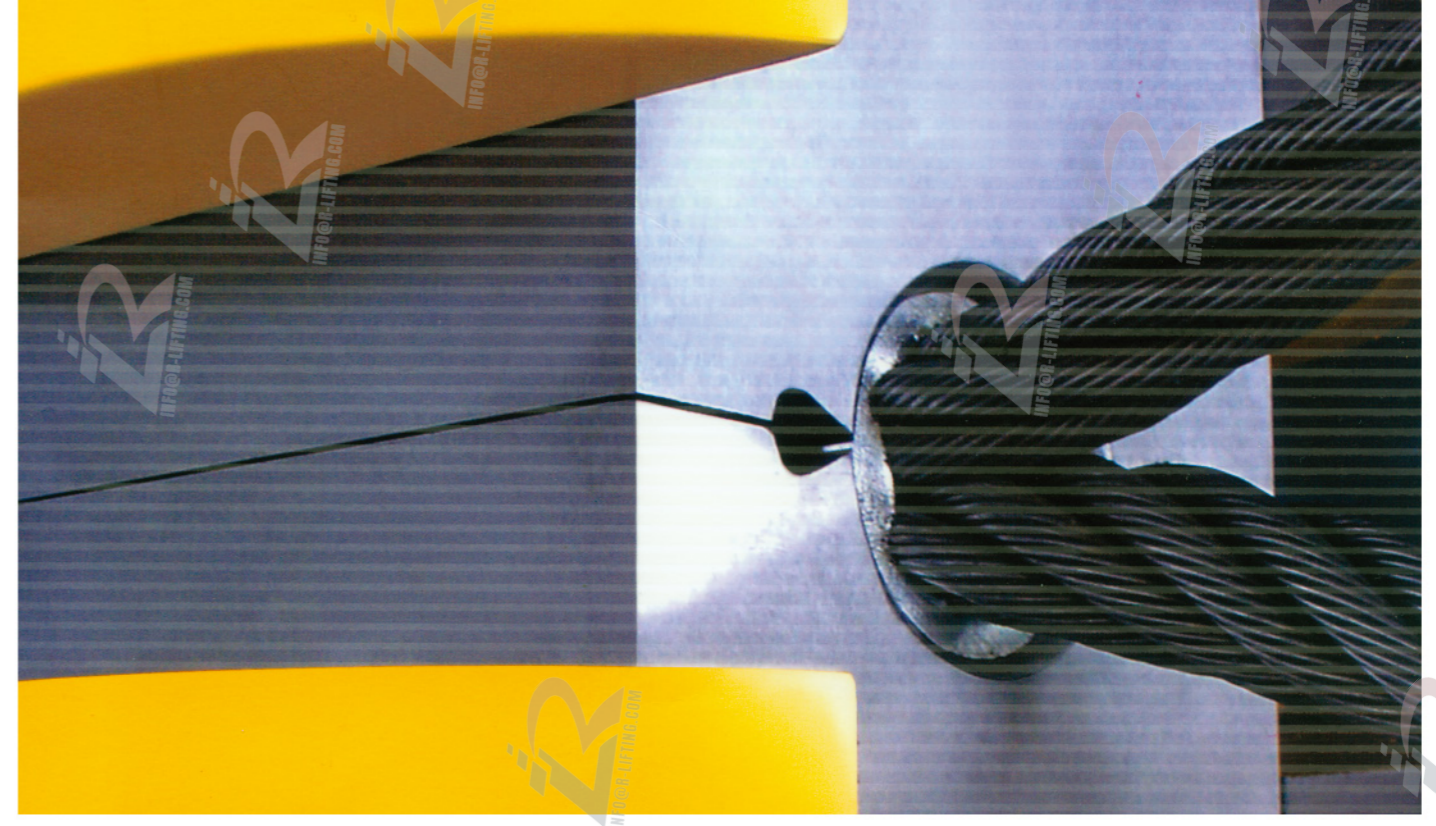

SWAGING MACHINE

Frame Style Hydraulic Swaging Machine SM350H/SM600H/SM1500H



Structure and Characteristic

With importing foreign advanced technology and new process and improving our years of production practice, H-Quality has developed a new generation of advanced wire rope swaging machine---Frame Hydraulic Swaging Machine.

- 1.The Frame are designed to use prestress wire rope wind-up technology, it distributes the stress around the frame homogeneously, and makes the Bodies never cracking.
- 2.With guiding and sliding devices on the die seats, the upper and lower dies can be replaced conveniently.

Major Technique Specification and Parameter

Items	Unit	Data		
Model		SM350H	SM600H	SM1500H
Max.Pressure Capacity	KN	3500	6000	15000
Swaging Capacity				
Aluminum Sleeve		#28	#36	#62
Flemish Steel Ferrule		1-1/8"	1-3/4"	3-1/2"
Maximum Stroke	mm	130	145	200
Working Stroke	mm	90	120	150
System Pressure	Mpa	60/7	60/7	70/7
Motor Power	KW	4	4	7.5
Dimensions	mm	1500×635×1500	1500×660×1650	1800×960×2100
Approx.Weight	kgs	≈1750	≈2300	≈6200

The exquisite technology, creates the perfect product

SWAGING MACHINE

C-Type Hydraulic Swaging Machine SM350C/SM600C



Structure and Characteristic

- 1.The C-Type bodies are made of one piece casting alloy steel, it makes the H-Quality Swaging Machine more durable and stronger.
- 2.Equipped with high pressure and low pressure oil pumps, the H-Quality Swaging Machine can steady load and unload so that the swaging quality is improved.
- 3.The dies are fully accessible in C-Type bodies design, allowing the rigger freely moves the slings around the swaging area.

Major Technique Specification and Parameter

Items	Unit	Data	
Model		SM350C	SM600C
Max.Pressure Capacity	KN	3500	6000
Swaging Capacity			
Aluminum Sleeve		#28	#36
Flemish Steel Ferrule		1-1/8"	1-3/4"
Maximum Stroke	mm	110	140
Working Stroke	mm	85	120
System Pressure	Mpa	60/7	60/7
Motor Power	KW	4	4
Dimensions	mm	1300×600×1600	1500×660×650
Approx.Weight	kgs	≈1800	≈4500

SWAGING MACHINE

Frame Style Hydraulic Swaging Machine SM3000H/SM5000H



Structure and Characteristic

1. The main working cylinder with "U" Type Cup Style Structural design, the piston and cylinder cover with latest style of over high pressure combined sealing device and high anti-wear guiding ring, it makes the cylinder more durable and more reliable.
2. With embedded design, the main cylinder is fixed in with the frame solidly.
3. Round independent dies can be set up and replaced quickly.
4. Swaging pressure value can be set by digital display and PLC control button.
5. With a strong afflatus of the Arc de Triomphe, SM3000H and SM5000H Swaging Machine looks grand and beautiful.

Major Technique Specification and Parameter

Items	Unit	Data	
Model		SM3000H	SM5000H
Max. Pressure Capacity	KN	30000	50000
Swaging Capacity			
Aluminum Sleeve		#84	#125
Flemish Steel Ferrule		5"	6"
Maximum Stroke	mm	270	420
Working Stroke	mm	240	370
System Pressure	Mpa	70/12	65/12
Motor Power	KW	7.2x2	7.5x4
Dimensions	mm	1270x1000x2800	1660x1275x3500
Approx. Weight	kgs	≈18000	≈30000



MANUAL TOOL

MULTI-FUNCTION SWAGING TOOL

Multi-function Swaging Tool Bench Type

Part No.	Size	N.W. kgs
MMBS2400	24"	2.5



Head drop-forged with alloy steel, body special heat treatment
 Cutting edges induction quenched
 Joint arms drop-forged, base precision casted, base measures 3 x 6" (76 x 152mm)
 Used for cutting 6mm wire rope and press 1/16" - 3/16" oval sleeve (Aluminum)
 Operating by one hand for easy cutting

Multi-function Swaging Tool

Part No.	Size	N.W. kgs
MMHS1400	14"	1.05
MMHS2400	24"	2.5

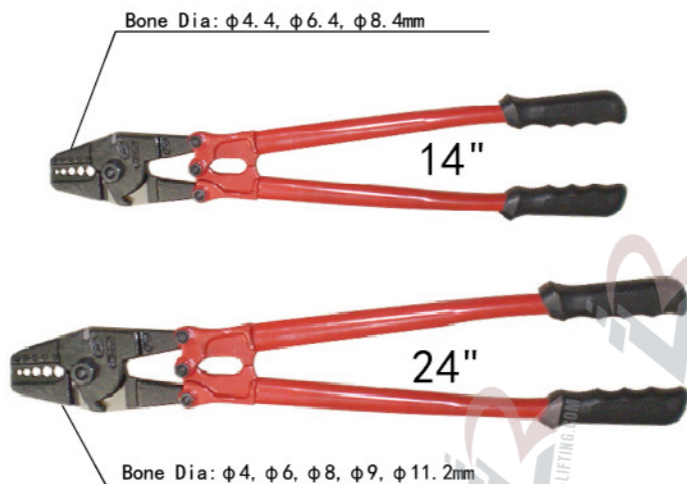

Blades drop-forged with high quality alloy steel, body heat treatment
 Cutting edges induction quenched,
 Used for cutting 6mm wire rope and press 1/16" - 3/16" oval sleeve (Aluminum)
 Industry class quality

BOLT CUTTER

Bolt Cutter, European Type

Drop forged blades with high quality carbon steel, body heat treatment, cutting edges induction quenched, easy adjustment, cutting ability ≤ HRC30

Part No.	Size inch	soft mm	medium mm	N.W. kgs
MECC1200	12	5	4	0.73
MECC1400	14	7	5	0.90
MECC1800	18	8	6	1.45
MECC2400	24	10	8	2.50
MECC3000	30	13	10	3.80
MECC3600	36	16	12	5.40
MECC4200	42	19	14	8.33
MECC4800	48	22	16	8.67



Bolt Cutter, European Type

Drop forged blades with Cr-V steel, body heat treatment, cutting edges, special straps, easy adjustment, cutting ability ≤ HRC40

Part No.	Size inch	soft mm	medium mm	N.W. kgs
MEAC1200	12	5	4	0.73
MEAC1400	14	7	5	0.90
MEAC1800	18	8	6	1.45
MEAC2400	24	10	8	2.50
MEAC3000	30	13	10	3.80
MEAC3600	36	16	12	5.40
MEAC4200	42	19	14	8.33
MEAC4800	48	22	16	8.67



Bolt Cutter, American Type

Drop forged blades with high quality carbon steel, body heat treatment, black finished on blades, easy adjustment, cutting ability ≤ HRC30



Drop forged blades with high quality carbon steel, body heat treatment, black finished on blades, easy adjustment, cutting ability ≤ HRC30

Part No.	Size inch	soft mm	medium mm	N.W. kgs
MUCC1200	12	5	4	0.70
MUCC1400	14	7	5	0.90
MUCC1800	18	8	6	1.45
MUCC2400	24	10	8	2.20
MUCC3000	30	13	10	4.00
MUCC3600	36	16	12	5.20
MUCC4200	42	19	14	8.33

LOAD BINDER

Lever Type Load Binder, Painted Red

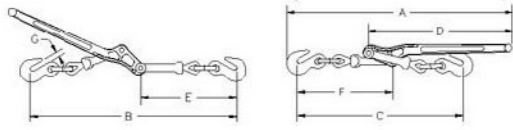

Part No.	Size	W.L.L.	Proof Load	Ultimate Load	N.W.	Handle Length	Take Up	Dimensions(inch)						
								A	B	C	D	E	F	G
MLLB0104	1/4-5/16	2600	5200	9200	3.52	11.42	3.75	18.50	17.30	14.17	11.42	8.27	8.07	0.35
MLLB0516	5/16-3/8	5400	10800	19000	8.37	15.43	4.50	25.20	23.20	19.49	15.55	11.22	11.22	0.51
MLLB0308	3/8-1/2	9200	18400	33000	12.20	17.24	4.50	28.50	26.38	22.05	17.64	12.99	12.20	0.59
MLLB0102	1/2-5/8	13000	26000	46000	19.70	21	4.75	33.86	30.12	25.78	20.84	14.37	13.37	0.74

Ratchet Type Load Binder, Painted Red

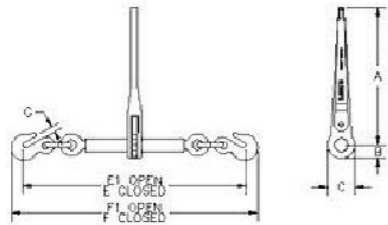

Part No.	Size	W.L.L.	Proof Load	Ultimate Load	N.W.	Handle Length	Dimensions(inch)								
							A	B	C	E	E1	F	F1	G	
MRLB0104	1/4-5/16	2600	5200	9200	3.52	7.16	7.16	0.89	1.17	16.22	21.26	17.79	22.83	0.35	
MRLB0516	5/16-3/8	5400	10800	19000	10.50	13.92	13.92	1.30	2.60	22.64	30.64	25.24	33.24	0.51	
MRLB0308	3/8-1/2	9200	18400	33000	12.90	13.92	13.92	1.30	2.60	24.13	32.13	12.20	35.04	0.59	
MRLB0102	1/2-5/8	13000	26000	46000	14.38	21.00	13.92	1.30	2.60	26.45	34.45	30.07	38.07	0.74	

Claw Load Binder, Painted Red



Part No.	Size	W.L.L.	Proof Load	Ultimate Load	N.W.	Handle Length
	inch	lbs.	lbs.	lbs.	lbs.	inch
MCLB0104	1/4-5/16	2600	5200	9200	3.60	11.42
MCLB0516	5/16-3/8	5400	10800	19000	8.56	15.43
MCLB0308	3/8-1/2	9200	18400	33000	12.38	17.24

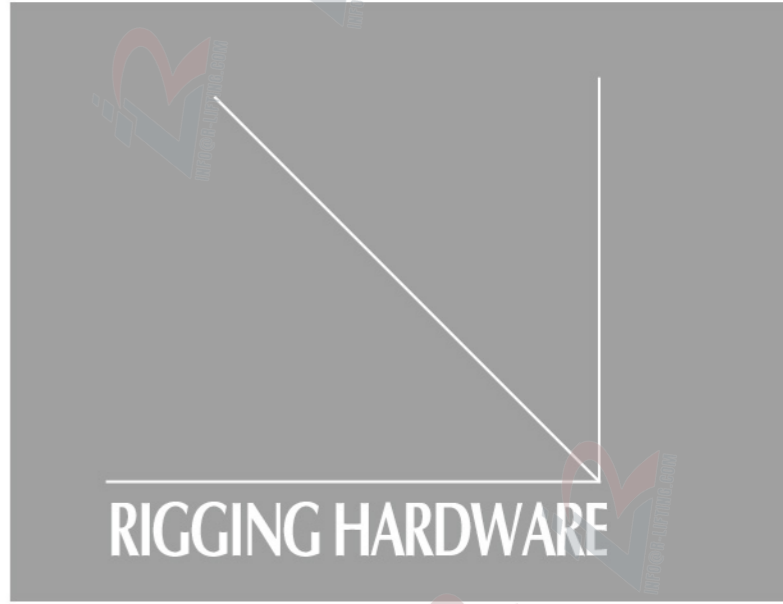
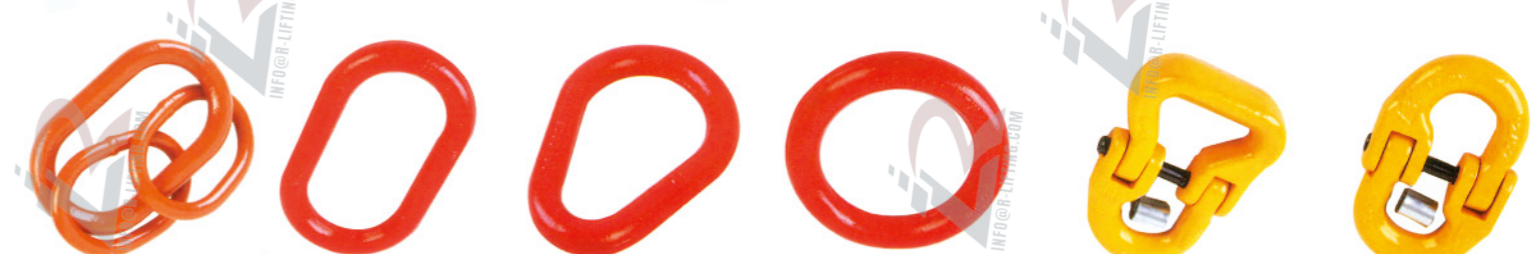

MANUAL TOOL

SHACKLE

Round Pin Anchor Shackles G-213

Round pin anchor shackles meet the performance requirements of Federal Specification RR-C-271D Type IVA, Grade A, Class 1, except for those provisions required of the contractor.

Part No.	Size (in.)	Working Load Limit (t)	Weight Each (lbs)	Dimensions(in.)											Tolerance +/-	
				A	B	C	D	E	F	G	H	N	P	C	A	
RRAS0104	1/4	1/2	0.13	0.47	0.31	1.13	0.25	0.78	0.61	1.28	1.84	1.34	0.25	0.06	0.06	
RRAS0516	5/16	3/4	0.18	0.53	0.38	1.22	0.31	0.84	0.75	1.47	2.09	1.59	0.31	0.06	0.06	
RRAS0308	3/8	1	0.29	0.66	0.44	1.44	0.38	1.03	0.91	1.78	2.49	1.86	0.38	0.13	0.06	
RRAS0716	7/16	1-1/2	0.38	0.75	0.50	1.69	0.44	1.16	1.06	2.03	2.91	2.13	0.44	0.13	0.06	
RRAS0102	1/2	2	0.71	0.81	0.63	1.88	0.50	1.31	1.19	2.31	3.28	2.38	0.50	0.13	0.06	
RRAS0508	5/8	3-1/4	1.50	1.06	0.75	2.38	0.63	1.69	1.50	2.94	4.19	2.91	0.69	0.13	0.06	
RRAS0304	3/4	4-3/4	2.32	1.25	0.88	2.81	0.75	2.00	1.81	3.50	4.97	3.44	0.81	0.25	0.06	
RRAS0708	7/8	6-1/2	3.49	1.44	1.00	3.31	0.88	2.28	2.09	4.03	5.83	3.81	0.97	0.25	0.06	
RRAS1000	1	8-1/2	5.00	1.69	1.13	3.75	1.00	2.69	2.38	4.69	6.56	4.53	1.06	0.25	0.06	
RRAS1108	1-1/8	9-1/2	6.97	1.81	1.25	4.25	1.13	2.91	2.69	5.16	7.47	5.13	1.25	0.25	0.06	
RRAS1104	1-1/4	12	9.75	2.03	1.38	4.69	1.29	3.25	3.00	5.75	8.25	5.50	1.38	0.25	0.06	
RRAS1308	1-3/8	13-1/2	13.25	2.25	1.50	5.25	1.42	3.63	3.31	6.38	9.16	6.13	1.50	0.25	0.13	
RRAS1102	1-1/2	17	17.25	2.38	1.63	5.75	1.54	3.88	3.63	6.88	10.00	6.50	1.62	0.25	0.13	
RRAS1304	1-3/4	25	29.46	2.88	2.00	7.00	1.84	5.00	4.19	8.86	12.34	7.75	2.25	0.25	0.13	
RRAS2000	2	35	45.75	3.25	2.25	7.75	2.08	5.75	4.81	9.97	13.68	8.75	2.40	0.25	0.13	

NOTE: Maximum Proof load is 2.0 times the Working Load Limit. Minimum Ultimate Strength is 6 times the Working Load Limit.

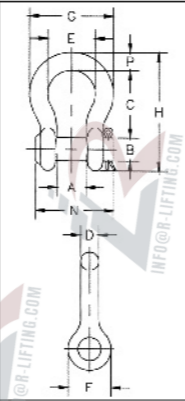

G-213

Round Pin Chain Shackles G-215

Round pin chain shackles meet the performance requirements of Federal Specification RR-C-271D Type IVB, Grade A, Class 1, except for those provisions required of the contractor.

Part No.	Nominal Size (in.)	Working Load Limit (t)	Weight Each (lbs)	Dimensions(in.)											Tolerance +/-	
				A	B	C	D	E	F	G	K	N	G	A		
RRCS0104	1/4	1/2	0.10	0.47	0.31	0.25	0.25	0.97	0.62	0.91	1.59	1.34	0.06	0.06		
RRCS0516	5/16	3/4	0.18	0.53	0.38	0.31	0.31	1.15	0.75	1.07	1.91	1.63	0.06	0.06		
RRCS0308	3/8	1	0.25	0.66	0.44	0.38	0.38	1.42	0.92	1.28	2.31	1.86	0.13	0.06		
RRCS0716	7/16	1-1/2	0.40	0.75	0.5	0.44	0.44	1.63	1.06	1.48	2.67	2.13	0.13	0.06		
RRCS0102	1/2	2	0.50	0.81	0.63	0.50	0.50	1.81	1.18	1.66	3.03	2.38	0.13	0.06		
RRCS0508	5/8	3-1/4	1.21	1.06	0.75	0.63	0.63	2.32	1.50	2.04	3.76	2.91	0.13	0.06		
RRCS0304	3/4	4-3/4	2.00	1.25	0.88	0.81	0.75	2.75	1.81	2.40	4.53	3.44	0.25	0.06		
RRCS0708	7/8	6-1/2	3.28	1.44	1.00	0.97	0.88	3.20	2.10	2.86	5.33	3.81	0.25	0.06		
RRCS1000	1	8-1/2	4.75	1.69	1.13	1.00	1.00	3.69	2.38	3.24	5.94	4.53	0.25	0.06		
RRCS1108	1-1/8	9-1/2	6.30	1.81	1.25	1.13	1.13	4.07	2.68	3.61	6.78	5.13	0.25	0.06		
RRCS1104	1-1/4	12	9.00	2.03	1.38	1.38	1.25	4.53	3.00	3.97	7.50	5.50	0.25	0.13		
RRCS1308	1-3/8	13-1/2	12.00	2.25	1.50	1.50	1.38	5.01	3.31	4.43	8.28	6.13	0.25	0.13		
RRCS1102	1-1/2	17	16.15	2.38	1.63	1.62	1.50	5.38	3.62	4.87	9.05	6.50	0.25	0.13		
RRCS1304	1-3/4	25	29.96	2.88	2.00	2.12	1.75	6.38	4.19	5.82	10.97	7.75	0.25	0.13		
RRCS2000	2	35	43.25	3.25	2.25	2.36	2.10	7.25	5.00	6.82	12.74	8.75	0.25	0.13		

NOTE: Maximum Proof load is 2.0 times the Working Load Limit. Minimum Ultimate Strength is 6 times the Working Load Limit.

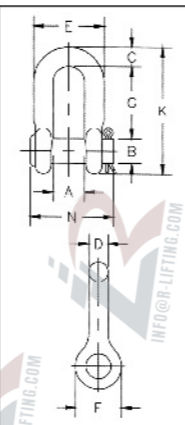

G-215

- Capacities 1/2 thru 35 metric tons.
- Forged-quenched and tempered, with alloy pins.
- Working Load Limit permanently shown on every shackle.
- Hot Dip galvanized or Self Colored.
- Fatigue rated.
- Shackles 25t and larger are RFID EQUIPPED.

SHACKLE

Screw Pin Anchor Shackles G-209

Screw pin anchor shackles meet the performance requirements of Federal Specification RR-C-271D Type IVA, Grade A, Class 2, except for those provisions required of the contractor.

Part No.	Size (in.)	Working Load Limit (t)	Weight Each (lbs)	Dimensions(in.)											Tolerance +/-	
				A	B	C	D	E	F	G	H	L	M	P	C	A
RSAS0316	3/16	1/3	0.06	0.38	0.25	0.88	0.19	0.60	0.56	0.98	1.47	0.16	1.14	0.19	0.06	0.06
RSAS0104	1/4	1/2	0.10	0.47	0.31	1.13	0.25	0.78	0.61	1.28	1.84	0.19	1.43	0.25	0.06	0.06
RSAS0516	5/16	3/4	0.19	0.53	0.38	1.22	0.31	0.84	0.75	1.47	2.09	0.22	1.71	0.31	0.06	0.06
RSAS0308	3/8	1	0.31	0.66	0.44	1.44	0.38	1.03	0.91	1.78	2.49	0.25	2.02	0.38	0.13	0.06
RSAS0716	7/16	1-1/2	0.38	0.75	0.5	1.69	0.44	1.16	1.06	2.03	2.91	0.31	2.37	0.44	0.13	0.06
RSAS0102	1/2	2	0.72	0.81	0.63	1.88	0.50	1.31	1.19	2.31	3.28	0.38	2.69	0.50	0.13	0.06
RSAS0508	5/8	3-1/4	1.37	1.06	0.75	2.38	0.63	1.69	1.50	2.94	4.19	0.44	3.34	0.69	0.13	0.06
RSAS0304	3/4	4-3/4	2.35	1.25	0.88	2.81	0.75	2.00	1.81	3.50	4.97	0.50	3.97	0.81	0.25	0.06
RSAS0708	7/8	6-1/2	3.62	1.44	1.00	3.31	0.88	2.28	2.09	4.03	5.83	0.50	4.50	0.97	0.25	0.06
RSAS1000	1	8-1/2	5.03	1.69	1.13	3.75	1.00	2.69	2.38	4.69	6.56	0.56	5.13	1.06	0.25	0.06
RSAS1108	1-1/8	9-1/2	7.41	1.81	1.25	4.25	1.16	2.91	2.69	5.16	7.47	0.63	5.71	1.25	0.25	0.06
RSAS1104	1-1/4	12	9.50	2.03	1.38	4.69	1.29	3.25	3.00	5.75	8.25	0.69	6.25	1.38	0.25	0.06
RSAS1308	1-3/8	13-1/2	13.53	2.25	1.50	5.25	1.42	3.63	3.31	6.38	9.16	0.75	6.83	1.50	0.25	0.13
RSAS1102	1-1/2	17	17.20	2.38	1.63	5.75	1.54	3.88	3.63	6.88	10.00	0.81	7.33	1.62	0.25	0.13
RSAS1304	1-3/4	25	27.78	2.88	2.00	7.00	1.84	5.00	4.19	8.86	12.34	1.00	9.06	2.25	0.25	0.13
RSAS2000	2	35	45.00	3.25	2.25	7.75	2.08	5.75	4.81	9.97	13.68	1.22	10.35	2.40	0.25	0.13
RSAS2102	2-1/2	55	85.75	4.13	2.75	10.50	2.71	7.25	5.69	12.87	17.84	1.38	13.00	3.13	0.25	0.25

NOTE: Maximum Proof load is 2.0 times the Working Load Limit. Minimum Ultimate Strength is 6 times the Working Load Limit.

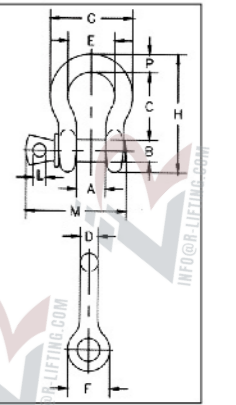

G-209

Screw Pin Chain Shackles G-210

Screw pin chain shackles meet the performance requirements of Federal Specification RR-C-271D Type IVB, Grade A, Class 2, except for those provisions required of the contractor.

Part No.	Size (in.)	Working Load Limit (t)	Weight Each (lbs)	Dimensions(in.)											Tolerance +/-	
				A	B	C	D	E	F	G	K	L	M	G	A	
RSCS0104	1/4	1/2	0.11	0.47	0.31	0.25	0.25	0.97	0.62	0.97	1.59	0.19	1.43	0.06	0.06	
RSCS0516	5/16	3/4	0.17	0.53	0.38	0.31	0.31	1.15	0.75	1.07	1.91	0.22	1.71	0.06	0.06	
RSCS0308	3/8	1	0.28	0.66	0.44	0.38	0.38	1.42	0.92	1.28	2.31	0.25	2.02	0.13	0.06	
RSCS0716	7/16	1-1/2	0.43	0.75	0.50	0.44	0.44	1.63	1.06	1.48	2.67	0.31	2.37	0.13	0.06	
RSCS0102	1/2	2	0.59	0.81	0.63	0.50	0.50	1.81	1.18	1.66	3.03	0.38	2.69	0.13	0.06	
RSCS0508	5/8	3-1/4	1.25	1.06	0.75	0.63	0.63	2.32	1.50	2.04	3.76	0.44	3.34	0.13	0.06	
RSCS0304	3/4	4-3/4	2.63	1.25	0.88	0.81	0.75	2.75	1.81	2.40	4.53	0.50	3.97	0.25	0.06	
RSCS0708	7/8	6-1/2	3.16	1.44	1.00	0.97	0.88	3.20	2.10	2.86	5.33	0.50	4.50	0.25	0.06	
RSCS1000	1	8-1/2	4.75	1.69	1.13	1.00	1.00	3.69	2.38	3.24	5.94	0.56	5.13	0.25	0.06	
RSCS1108	1-1/8	9-1/2	6.75	1.81	1.25	1.25	1.13	4.07	2.69	3.61	6.78	0.63	5.71	0.25	0.06	
RSCS1104	1-1/4	12	9.06	2.03	1.38	1.38	1.25	4.53	3.00	3.97	7.50	0.69	6.25	0.25	0.13	
RSCS1308	1-3/8	13-1/2	11.63	2.25	1.50	1.50	1.38	5.01	3.31	4.43	8.28	0.75	6.83	0.25	0.13	
RSCS1102	1-1/2	17	15.95	2.38	1.63	1.62	1.50	5.38	3.62	4.84	9.05	0.81	7.33	0.25	0.13	
RSCS1304	1-3/4	25	26.75	2.88	2.00	2.12	1.75	6.38	4.19	5.78	10.97	1.00	9.06	0.25	0.13	
RSCS2000	2	35	42.31	3.25	2.25	2.36	2.10	7.25	5.00	6.77	12.74	1.13	10.35	0.25	0.13	
RSCS2102	2-1/2	55	71.75	4.12	2.75	2.63	2.63	9.38	5.68	8.07	14.85	1.38	13.00	0.25	0.25	

NOTE: Maximum Proof load is 2.0 times the Working Load Limit. Minimum Ultimate Strength is 6 times the Working Load Limit.

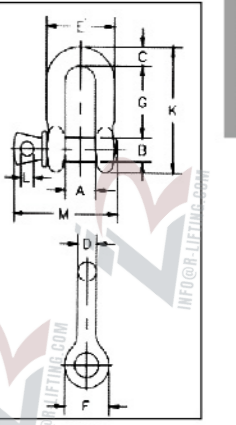

G-210

- Capacities 1/3 thru 55 metric tons.
- Forged-Quenched and Tempered, with alloy pins.
- Working Load Limit permanently shown on every shackle.
- Hot Dip galvanized or Self Colored.
- Fatigue rated.
- Shackles 25t and larger are RFID EQUIPPED.
- Shackles are Quenched and Tempered and can meet DNV impact requirements of 42 joules at -20 degree C.

SHACKLE

Bolt Type Anchor Shackles G-2130

Bolt type anchor shackles with thin head bolt-nut with cotter pin. Meets the performance requirements of Federal Specification RR-C-271D Type IVA, Grade A, Class 3, except for those provisions required of the contractor.

Part No.	Size (in.)	Working Load Limit (t)	Weight Each (lbs)	Dimensions (in.)										Tolerance +/-		
				A	B	C	D	E	F	H	L	N	C	A		
RBAS0316	3/16	1/3	0.06	0.38	0.25	0.88	0.19	0.6	0.56	1.47	0.98	0.19	0.06	0.06		
RBAS0104	1/4	1/2	0.11	0.47	0.31	1.13	0.25	0.78	0.61	1.84	1.28	0.25	0.06	0.06		
RBAS0516	5/16	3/4	0.22	0.53	0.38	1.22	0.31	0.84	0.75	2.09	1.47	0.31	0.06	0.06		
RBAS0308	3/8	1	0.33	0.66	0.44	1.44	0.38	1.03	0.91	2.49	1.78	0.38	0.13	0.06		
RBAS0716	7/16	1-1/2	0.49	0.75	0.50	1.69	0.44	1.16	1.06	2.91	2.03	0.44	0.13	0.06		
RBAS0102	1/2	2	0.79	0.81	0.64	1.88	0.50	1.31	1.19	3.28	2.31	0.50	0.13	0.06		
RBAS0508	5/8	3-1/4	1.68	1.06	0.77	2.38	0.63	1.69	1.50	4.19	2.94	0.69	0.13	0.06		
RBAS0304	3/4	4-3/4	2.72	1.25	0.89	2.81	0.75	2.00	1.81	4.97	3.50	0.81	0.25	0.06		
RBAS0708	7/8	6-1/2	3.95	1.44	1.02	3.31	0.88	2.28	2.09	5.83	4.03	0.97	0.25	0.06		
RBAS1000	1	8-1/2	5.66	1.69	1.15	3.75	1.00	2.69	2.38	6.56	4.69	1.06	0.25	0.06		
RBAS1108	1-1/8	9-1/2	8.27	1.81	1.25	4.25	1.13	2.91	2.69	7.47	5.16	1.25	0.25	0.06		
RBAS1104	1-1/4	12	11.71	2.03	1.40	4.69	1.29	3.25	3.00	8.25	5.75	1.38	0.25	0.06		
RBAS1308	1-3/8	13-1/2	15.83	2.25	1.53	5.25	1.42	3.63	3.31	9.16	6.38	1.50	0.25	0.13		
RBAS1102	1-1/2	17	19.00	2.38	1.66	5.75	1.53	3.88	3.63	10.00	6.88	1.62	0.25	0.13		
RBAS1304	1-3/4	25	33.91	2.88	2.04	7.00	1.84	5.00	4.19	12.34	8.80	2.25	0.25	0.13		
RBAS2000	2	35	52.25	3.25	2.30	7.75	2.08	5.75	4.81	13.68	10.15	2.40	0.25	0.13		
RBAS2102	2-1/2	55	98.25	4.13	2.80	10.50	2.71	7.25	5.69	17.90	12.75	3.13	0.25	0.25		
RBAS3000	3	85	154.00	5.00	3.30	13.00	3.12	7.88	6.50	21.50	14.62	3.62	0.25	0.25		
RBAS3102	3-1/2	120	265.00	5.25	3.76	14.63	3.62	9.00	8.00	24.88	17.02	4.38	0.25	0.25		
RBAS4000	4	150	338.00	5.50	4.26	14.50	4.00	10.00	9.00	25.68	18.00	4.56	0.25	0.25		

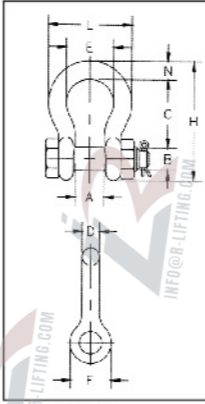

G-2130

Bolt Type Chain shackles G-2150

Bolt Type Chain shackles. Thin hex head bolt-nut with cotter pin. Meets the performance requirements of Federal Specification RR-C-271D Type IVB, Grade A, Class 3, except for those provisions required of the contractors.

Part No.	Size (in.)	Working Load Limit (t)	Weight Each (lbs)	Dimensions (in.)										Tolerance +/-		
				A	B	D	F	G	K	M	P	R	G	A		
RBCS0104	1/4	1/2	0.13	0.47	0.31	0.25	0.62	0.91	1.59	0.97	1.56	0.25	0.06	0.06		
RBCS0516	5/16	3/4	0.23	0.53	0.38	0.31	0.75	1.07	1.91	1.15	1.82	0.31	0.06	0.06		
RBCS0308	3/8	1	0.33	0.66	0.44	0.38	0.92	1.28	2.31	1.42	2.17	0.38	0.13	0.06		
RBCS0716	7/16	1-1/2	0.49	0.75	0.50	0.44	1.06	1.48	2.67	1.63	2.51	0.44	0.13	0.06		
RBCS0102	1/2	2	0.75	0.81	0.64	0.50	1.18	1.66	3.03	1.81	2.80	0.50	0.13	0.06		
RBCS0508	5/8	3-1/4	1.47	1.06	0.77	0.63	1.50	2.04	3.76	2.32	3.56	0.63	0.13	0.06		
RBCS0304	3/4	4-3/4	2.52	1.25	0.89	0.75	1.81	2.40	4.53	2.75	4.15	0.81	0.25	0.06		
RBCS0708	7/8	6-1/2	3.85	1.44	1.02	0.88	2.10	2.86	5.33	3.20	4.82	0.97	0.25	0.06		
RBCS1000	1	8-1/2	5.55	1.69	1.15	1.00	2.38	3.24	5.94	3.69	5.39	1.00	0.25	0.06		
RBCS1108	1-1/8	9-1/2	7.60	1.81	1.25	1.13	2.68	3.61	6.78	4.07	5.90	1.25	0.25	0.06		
RBCS1104	1-1/4	12	10.81	2.03	1.40	1.25	3.00	3.97	7.50	4.53	6.69	1.38	0.25	0.06		
RBCS1308	1-3/8	13-1/2	13.75	2.25	1.53	1.38	3.31	4.43	8.28	5.01	7.21	1.50	0.25	0.13		
RBCS1102	1-1/2	17	18.50	2.38	1.66	1.50	3.62	4.87	9.05	5.38	7.73	1.62	0.25	0.13		
RBCS0304	1-3/4	25	31.40	2.88	2.04	1.75	4.19	5.82	10.97	6.38	9.33	2.12	0.25	0.13		
RBCS2000	2	35	46.75	3.25	2.30	2.10	5.00	6.82	12.74	7.25	10.41	2.36	0.25	0.13		
RBCS2102	2-1/2	55	85.00	4.12	2.80	2.63	5.68	8.07	14.85	9.38	13.58	2.63	0.25	0.25		
RBCS3000	3	85	124.25	5.00	3.25	3.00	6.50	8.56	16.87	11.00	15.13	3.50	0.25	0.25		

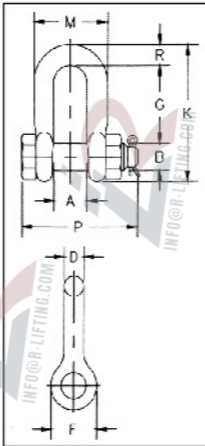

G-2150

NOTE: Maximum Proof Load is 2.0 times the Working Load Limit. Minimum Ultimate Strength is 6 times the Working Load Limit.
Individually Proof Tested with certification.
Furnished in Anchor style only and furnished with Round Head Bolts with welded handles.

- Capacities 1/3 thru 150 metric tons.
- Working Load Limit permanently shown on every shackle.
- Forged-Quenched and Tempered, with alloy pins.
- Hot Dip galvanized or Self Colored.
- Fatigue rated. (1/3t-55t)
- Shackles 25t and larger are RFID EQUIPPED.

SHACKLE

Commercial Grade Screw Pin Anchor Shackle U.S.Type

Part No.	Size mm	W.L.L. ton	PIN DIA. inch	I.L. inch	N.W. lbs
RCAS0316	3/16	1/4	1/4	7/8	0.05
RCAS0104	1/4	1/3	5/16	1-1/8	0.12
RCAS0516	5/16	1/2	3/8	1-7/32	0.19
RCAS0308	3/8	3/4	7/16	1-7/16	0.31
RCAS0716	7/16	1	1/2	1-11/16	0.38
RCAS0102	1/2	1-1/2	5/8	1-7/8	0.63
RCAS0508	5/8	2-1/4	3/4	2-3/8	1.38
RCAS0304	3/4	3-1/4	7/8	2-13/16	2.25
RCAS0708	7/8	4-1/4	1	3-5/16	3.38
RCAS1000	1	5-1/2	1-1/8	3-3/4	5.32

M.B.S. IS 4 TIMES OF W.L.L.



Commercial Grade Screw Pin Chain Shackle U.S.Type

Part No.	Size mm	W.L.L. ton	PIN DIA. inch	I.L. inch	N.W. lbs
RCCS0104	1/4	1/3	5/16	7/8	0.11
RCCS0516	5/16	1/2	3/8	1-1/32	0.17
RCCS0308	3/8	3/4	7/16	1-1/4	0.24
RCCS0716	7/16	1	1/2	1-7/16	0.40
RCCS0102	1/2	1-1/2	5/8	1-5/8	0.59
RCCS0508	5/8	2-1/4	3/4	2	1.21
RCCS0304	3/4	3-1/4	7/8	2-3/8	2.25
RCCS0708	7/8	4-1/4	1	2-13/16	3.16
RCCS1000	1	5-1/2	1-1/8	3-3/16	4.74

M.B.S. IS 4 TIMES OF W.L.L.



European Type Large Bow Shackle

Part No.	Size mm	W.L.L. kgs	I.L. mm	N.W. kg
REBS0050	5	80	19	0.019
REBS0060	6	100	25	0.034
REBS0080	8	200	32	0.070
REBS0100	10	320	38	0.130
REBS0120	12	520	51	0.260
REBS0160	16	800	64	0.500
REBS0200	20	1100	76	0.800
REBS0220	22	1500	89	1.300
REBS0250	25	2100	100	2.000
REBS0280	28	3000	115	3.000

M.B.S. IS 4 TIMES OF W.L.L.



SHACKLE

European Type Large Dee Shackle

Part No.	Size mm	W.L.L. kgs	I.L. mm	N.W. kg
REDS0050	5	80	19	0.018
REDS0060	6	100	25	0.032
REDS0080	8	200	32	0.067
REDS0100	10	320	38	0.126
REDS0120	12	520	51	0.235
REDS0160	16	800	64	0.494
REDS0200	20	1100	76	0.790
REDS0220	22	1500	89	1.280
REDS0250	25	2100	100	1.980
REDS0280	28	3000	115	2.970

M.B.S. IS 4 TIMES OF W.L.L.



JIS Type Screw Pin Anchor Shackle With Or Without Collar

Part No.	Size mm	W.L.L. kgs	I.L. mm	N.W. kg
RJAS0050	5	90	19	0.026
RJAS0060	6	150	25	0.028
RJAS0080	8	250	32	0.065
RJAS0100	10	400	38	0.080
RJAS0120	12	600	51	0.200
RJAS0160	16	800	64	0.495
RJAS0200	20	1000	76	0.800
RJAS0220	22	1500	89	1.260
RJAS0250	25	2000	100	1.900
RJAS0280	28	2500	115	2.650

M.B.S. IS 4 TIMES OF W.L.L.



JIS Type Screw Pin Chain Shackle With Or Without Collar

Part No.	Size mm	W.L.L. kgs	I.L. mm	N.W. kg
RJCS0050	5	90	16	0.014
RJCS0060	6	150	22	0.028
RJCS0080	8	250	27	0.049
RJCS0100	10	400	31	0.073
RJCS0120	12	600	40	0.180
RJCS0160	16	800	51	0.420
RJCS0200	20	1000	64	0.720
RJCS0220	22	1500	75	1.180
RJCS0250	25	2000	83	1.800
RJCS0280	28	2500	96	2.500

M.B.S. IS 4 TIMES OF W.L.L.



WIRE ROPE CLIP

U.S. Type Malleable Wire Rope Clips,ZP

Part No.	Size inch	N.W. kg/100pcs	Part No.	Size inch	N.W. kg/100pcs
RUWC0116	1/16	0.80	RUWC0102	1/2	18.50
RUWC0108	1/8	1.54	RUWC0916	9/16	22.56
RUWC0316	3/16	2.50	RUWC0508	5/8	28.00
RUWC0104	1/4	5.30	RUWC0304	3/4	35.00
RUWC0516	5/16	5.90	RUWC0708	7/8	53.00
RUWC0308	3/8	10.00	RUWC1000	1	66.60
RUWC0716	7/16	11.30	RUWC1108	1-1/8	111.00

MEET FEDERAL SPECIFICATION FF-C-450 TYPE 1 CLASS 2



DIN 741 Malleable Wire Rope Clips,ZP

Part No.	Size mm	N.W. kg/100pcs	Part No.	Size mm	N.W. kg/100pcs
R7MC0030	3	1.40	R7MC0160	16	21.00
R7MC0050	5	1.50	R7MC0190	19	28.00
R7MC0065	6.5	2.10	R7MC0220	22	40.00
R7MC0080	8	4.10	R7MC0260	26	44.00
R7MC0100	10	6.80	R7MC0300	30	66.00
R7MC0110	11	7.20	R7MC0340	34	85.00
R7MC0130	13	13.00	R7MC0400	40	104.00
R7MC0140	14	13.50			



DIN 1142 Wire Rope Clips, Yellow Chromated

Part No.	Size mm	N.W. kg/100pcs	Part No.	Size mm	N.W. kg/100pcs
R1MC0050	5	2.08	R1MC0190	19	49.00
R1MC0065	6.5	4.00	R1MC0220	22	68.00
R1MC0080	8	8.20	R1MC0260	26	117.00
R1MC0100	10	9.20	R1MC0300	30	140.00
R1MC0130	13	27.50	R1MC0340	34	213.00
R1MC0160	16	43.00	R1MC0400	40	268.00



Wire Rope Clip Type A, Yellow Chromated

Part No.	Size mm	N.W. kg/100pcs	Part No.	Size mm	N.W. kg/100pcs
RWCA0060	6	2.10	RWCA0200	20	43.00
RWCA0080	8	3.70	RWCA0220	22	60.00
RWCA0100	10	8.50	RWCA0250	25	82.00
RWCA0120	12	16.00	RWCA0280	28	112.00
RWCA0150	15	25.00	RWCA0320	32	150.00



WIRE ROPE CLIP

Wire Rope Clip Type B, Malleable, ZP

Part No.	Size inch	N.W. kg/100pcs	Part No.	Size inch	N.W. kg/100pcs
RWCB0108	1/8	1.30	RWCB0508	5/8	23.20
RWCB0316	3/16	1.60	RWCB1116	1 1/16	30.30
RWCB0104	1/4	2.40	RWCB0304	3/4	45.00
RWCB0516	5/16	3.70	RWCB0708	7/8	58.00
RWCB0308	3/8	8.10	RWCB1000	1	89.00
RWCB0102	1/2	14.60			



U.S. Type Drop Forged Wire Rope Clip, H.D.G.

Part No.	Size inch	N.W. kg/100pcs	Part No.	Size inch	N.W. kg/100pcs
RUFC0108	1/8	5.00	RUFC0708	7/8	240.00
RUFC0316	3/16	9.00	RUFC1000	1	250.00
RUFC0104	1/4	18.00	RUFC1108	1-1/8	310.00
RUFC0516	5/16	30.00	RUFC1104	1-1/4	460.00
RUFC0308	3/8	42.00	RUFC1308	1-3/8	520.00
RUFC0716	7/16	70.00	RUFC1102	1-1/2	590.00
RUFC0102	1/2	75.00	RUFC1508	1-5/8	730.00
RUFC0916	9/16	100.00	RUFC1304	1-3/4	980.00
RUFC0508	5/8	100.00	RUFC2000	2	1340.00
RUFC0304	3/4	150.00	RUFC2104	2-1/4	1570.00



MEET FEDERAL SPECIFICATION FF-C-450 TYPE I CLASS I

U.S. Type Drop Forged Fist Grip Clip, H.D.G.

Part No.	Size inch	N.W. kg/100pcs	Part No.	Size inch	N.W. kg/100pcs
RUFG0316	3/16-1/4	8.16	RUFG0916	9/16-5/8	45.36
RUFG0516	5/16	12.70	RUFG0304	3/4	79.38
RUFG0308	3/8	18.14	RUFG0708	7/8	102.06
RUFG0716	7/16	31.75	RUFG1000	1	136.08



MEET FEDERAL SPECIFICATION FF-C-450 TYPE II CLASS I

TURNBUCKLE

Turnbuckles DIN 1480

Part No.	Size mm	W.L.L. N	Total Length mm	Body Length mm	N.W. kg/100pcs
RD1T0060	M6	2250	180	110	7.8
RD1T0080	M8	4100	195	110	14.8
RD1T0100	M10	6500	230	125	29.4
RD1T0120	M12	9300	250	125	36.3
RD1T0160	M16	13000	320	170	56.0
RD1T0200	M20	17700	400	200	156.0
RD1T0220	M22	32000	428	220	230.0
RD1T0240	M24	39200	490	255	325.0
RD1T0300	M30	62500	530	255	415.0



Turnbuckles Commercial Type With Hook and Eye

Part No.	Size mm	W.L.L. kgs	Total Length mm	Body Length mm	N.W. kg/pc
RCTT0060	6	100	215	100	0.048
RCTT0080	8	200	280	125	0.088
RCTT0100	10	300	325	150	0.130
RCTT0120	12	500	430	200	0.310
RCTT0160	16	1000	540	250	0.610
RCTT0200	20	1500	670	300	1.100
RCTT0220	22	2200	740	330	1.720
RCTT0240	24	3000	830	350	2.100



Turnbuckles JIS Frame Type With Eye and Hook

Part No.	Size mm	T.L. ton	Body Length mm	N.W. kg
RJTT0060	6	1.0	100	0.116
RJTT0080	8	1.2	125	0.220
RJTT0100	10	1.5	150	0.295
RJTT0120	12	2.0	200	0.600
RJTT0160	16	3.0	250	1.070
RJTT0200	20	4.0	300	1.790
RJTT0220	22	5.0	330	2.550
RJTT0240	24	6.0	350	3.800



Rigging Screws With Jaw and Jaw

Part No.	Size mm	T.L. ton	Body Length mm	N.W. kg
RRST0120	M12	1.00	229	0.67
RRST0160	M16	1.50	229	1.20
RRST0200	M20	2.25	229	2.15
RRST0220	M22	3.25	305	3.25
RRST0240	M24	4.25	356	5.20
RRST0270	M27	5.25	368	6.75
RRST0320	M32	7.25	381	9.35
RRST0390	M39	10.25	406	11.20

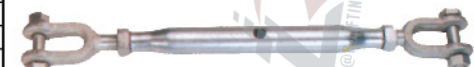

Turnbuckles U.S. Type, Drop Forged

Part No.	Size (inch) (Dia. x Take-up)	Approx Weight Each (lbs)					W.L.L. (lbs)	
		Eyes&/or Hooks	Jaw&Eye	Jaw&Jaw	Stub End	Body only	H&H H&E	E&E J&E J&J Stub End
HUT40104	1/4" x 4"	0.30	0.30	0.40	0.29	0.17	400	500
HUT40516	5/16" x 4" - 1/2"	0.50	0.53	0.58	0.46	0.25	700	800
HUT60308	3/8" x 6"	0.75	0.82	0.93	0.75	0.30	1000	1200
HUT60102	1/2" x 6"	1.50	1.62	1.68	1.36	0.55	1500	2200
HUT90102	1/2" x 9"	1.75	1.82	1.85	1.69	0.74	1500	2200
HUT20102	1/2" x 12"	2.18	2.19	2.20	2.00	0.93	1500	2200
HUT60508	5/8" x 6"	2.63	2.59	2.82	2.15	0.91	2250	3500
HUT90508	5/8" x 9"	3.00	3.01	3.25	2.70	1.20	2250	3500
HUT20508	5/8" x 12"	3.25	3.50	3.75	3.22	1.50	2250	3500
HUT60304	3/4" x 6"	3.75	4.25	4.68	3.25	1.30	3000	5200
HUT90304	3/4" x 9"	4.50	5.00	5.38	4.00	1.70	3000	5200
HUT20304	3/4" x 12"	5.75	5.75	6.12	4.65	2.12	3000	5200
HUT80304	3/4" x 18"	7.00	7.25	7.25	6.12	2.93	3000	5200
HUT60708	7/8" x 6"	5.85	6.29	6.84	4.75	2.00	4000	7200
HUT20708	7/8" x 12"	8.38	8.88	9.36	6.67	3.00	4000	7200
HUT80708	7/8" x 18"	10.25	10.60	11.44	8.75	4.12	4000	7200
HUT61000	1" x 6"	8.76	9.16	9.51	6.41	2.50	5000	10000
HUT21000	1" x 12"	11.25	12.00	12.88	8.90	3.86	5000	10000
HUT81000	1" x 18"	14.00	14.75	16.10	11.70	5.50	5000	10000
HUT41000	1" x 24"	17.00	17.75	18.60	14.30	7.00	5000	10000
HUT61104	1-1/4" x 6"	15.45	16.03	16.69	10.40	4.00	6500	15200
HUT21104	1-1/4" x 12"	19.00	21.20	23.60	14.20	5.93	6500	15200
HUT81104	1-1/4" x 18"	24.10	26.00	26.60	18.00	8.00	6500	15200
HUT41104	1-1/4" x 24"	25.00	28.70	31.20	21.80	10.00	6500	15200
HUT61102	1-1/2" x 6"	---	---	---	15.40	5.80	7500	21400
HUT21102	1-1/2" x 12"	27.00	31.10	35.50	20.50	8.40	7500	21400
HUT81102	1-1/2" x 18"	31.20	36.40	40.70	26.20	11.50	7500	21400
HUT41102	1-1/2" x 24"	38.20	44.20	47.60	31.40	14.10	7500	21400
HUT63304	1-3/4" x 6"	---	---	---	22.70	8.75	---	28000
HUT81304	1-3/4" x 18"	45.20	48.80	52.40	---	---	---	28000
HUT41304	1-3/4" x 24"	58.00	60.00	64.00	43.90	19.50	---	28000
HUT62000	2" x 6"	---	---	---	31.50	12.50	---	37000
HUT42000	2" x 24"	90.00	102.00	115.00	60.30	27.50	---	37000
HUT62102	2-1/2" x 6"	---	---	---	60.80	27.00	---	60000
HUT42102	2-1/2" x 24"	180.00	183.00	200.00	110.00	54.00	---	60000
HUT42304	2-3/4" x 24"	210.00	214.00	248.00	---	67.00	---	75000

PROOF LOAD IS 2.5 TIMES OF W.L.L.; M.B.S. IS 5 TIMES OF W.L.L.
MEET FEDERAL SPECIFICATION FF-T791b ,TYPE I FORM I

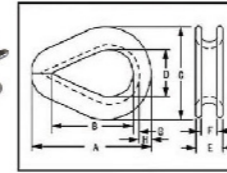

- Hot Dip Galvanized steel.
- The standard choice for light duty applications and loading conditions.

G-411 meets the performance requirements of Federal Specification FF-T-276b Type II, except for those provisions required of the contractor.

Standard Wire Rope Thimbles

Part No.	Rope Dia. (inch)	Weight per 100 (lbs.)	Dimensions (inch)							
			A	B	C	D	E	F	G	H
RLDT0108	1/8	3.50	1.94	1.31	1.06	0.69	0.25	0.16	0.05	0.13
RLDT0316	3/16	3.50	1.94	1.31	1.06	0.69	0.31	0.22	0.05	0.13
RLDT0104	1/4	3.50	1.94	1.31	1.06	0.69	0.38	0.28	0.05	0.13
RLDT0516	5/16	4.00	2.13	1.50	1.25	0.81	0.44	0.34	0.05	0.13
RLDT0308	3/8	6.70	2.38	1.63	1.47	0.94	0.53	0.41	0.06	0.16
RLDT0102	1/2	12.50	2.75	1.88	1.75	1.13	0.69	0.53	0.08	0.19
RLDT0508	5/8	34.50	3.50	2.25	2.38	1.38	0.91	0.66	0.13	0.34
RLDT0304	3/4	47.10	3.75	2.50	2.69	1.63	1.08	0.78	0.14	0.34
RLDT0708	7/8	84.60	5.00	3.50	3.19	1.88	1.27	0.94	0.16	0.44
RLDT1000	1	97.50	5.69	4.25	3.75	2.50	1.39	1.06	0.16	0.41
RLDT1108	1-1/8-1-1/4	175.00	6.25	4.50	4.31	2.75	1.75	1.31	0.22	0.50

- Available in Hot Dip galvanized or Stainless Steel (Type 304).
- Stainless steel recommended for more corrosive environments where greater protection is required.
- Greater protection against wear and deformation of the wire rope eye.
- Longer service life.

G-414 meets the performance requirements of Federal Specification FF-T-276b Type III, except for those provisions required of the contractor.

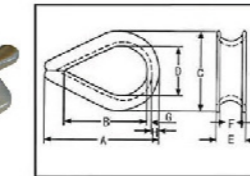

Extra Heavy Wire Rope Thimbles, H.D.G.

Part No.	Rope Dia. (inch)	Weight per 100 (lbs.)	Dimensions (inch)							
			A	B	C	D	E	F	G	H
RHDT0104	1/4	6.50	2.19	1.62	1.50	0.88	0.41	0.28	0.06	0.25
RHDT0516	5/16	11.80	2.50	1.88	1.81	1.06	0.50	0.34	0.08	0.30
RHDT0308	3/8	21.60	2.88	2.12	2.12	1.12	0.63	0.41	0.11	0.39
RHDT0716	7/16	34.70	3.25	2.38	2.38	1.25	0.72	0.47	0.12	0.45
RHDT0916	1/2-9/16	51.00	3.62	2.75	2.75	1.50	0.89	0.59	0.15	0.48
RHDT0508	5/8	75.70	4.25	3.25	3.12	1.75	1.00	0.66	0.16	0.53
RHDT0304	3/4	158.10	5.00	3.75	3.81	2.00	1.22	0.78	0.22	0.69
RHDT0708	7/8	177.80	5.50	4.25	4.25	2.25	1.38	0.94	0.22	0.78
RHDT1000	1	313.90	6.12	4.50	4.75	2.50	1.56	1.06	0.25	0.88
RHDT1104	1-1/8-1-1/4	400.00	7.00	5.12	5.88	2.88	1.88	1.31	0.25	1.25
RHDT1308	1-1/4-1-3/8	886.00	9.08	6.50	6.81	3.50	2.25	1.44	0.37	1.29
RHDT1102	1-3/8-1-1/2	1294.00	9.00	6.25	7.12	3.50	2.62	1.56	0.50	1.31
RHDT1508	1-5/8	1700.00	11.25	8.00	8.12	4.00	3.00	1.72	0.50	1.38
RHDT1304	1-3/4	1775.00	12.19	9.00	8.50	4.50	3.06	1.84	0.50	1.50
RHDT2000	1-7/8-2	2775.00	15.12	12.00	10.38	6.00	3.38	2.09	0.50	1.69
RHDT2104	2-1/4	3950.00	17.50	14.00	11.88	7.00	3.88	2.38	0.62	1.82

*SS-414 sizes available in stainless steel type 304.

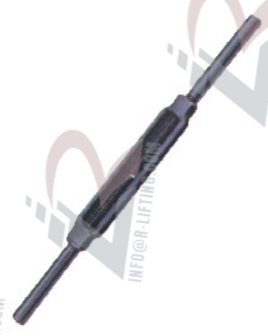

H/E

J/E

J/J

STUB END

THIMBLE

DIN 6899A Thimble

Part No.	Rope Dia. (mm)	Weight kg/100pcs
R6AT0025	2.5	0.14
R6AT0030	3	0.35
R6AT0040	4	0.42
R6AT0050	5	0.80
R6AT0060	6	0.85
R6AT0070	7	1.10
R6AT0080	8	1.70
R6AT0090	9	2.10
R6AT0100	10	3.50
R6AT0110	11	3.70
R6AT0120	12	5.25
R6AT0130	13	7.25
R6AT0140	14	8.33
R6AT0160	16	12.30



DIN 6899B Thimble

Part No.	Rope Dia. (mm)	Weight kg/100pcs
R6BT0025	2.5	0.5
R6BT0035	3.5	0.8
R6BT0040	4	1
R6BT0050	5	1.6
R6BT0060	6	1.9
R6BT0070	7	3
R6BT0090	9	4.7
R6BT0100	10	6.8
R6BT0130	13	8
R6BT0140	14	10
R6BT0150	15	14.5
R6BT0170	17	18
R6BT0160	16	20
R6BT0180	18	29
R6BT0200	20	32
R6BT0220	22	47
R6BT0240	24	59
R6BT0260	26	80
R6BT0280	28	110
R6BT0300	30	123
R6BT0320	32	156



BS464 Wire Rope Thimble, H.D.G.

Part No.	Rope Dia. (mm)	N.W. kg/100pcs
RBST0104	1/4"	4
RBST0516	5/16"	6
RBST0308	3/8"	8
RBST0716	7/16"	11
RBST0102	1/2"	13
RBST0916	9/16"	14
RBST0508	5/8"	25
RBST1116	11/16"	35
RBST0304	3/4"	46
RBST0708	7/8"	62
RBST1516	15/16"	82
RBST1000	1"	92
RBST1108	1-1/8"	120
RBST1104	1-1/4"	140
RBST1308	1-3/8"	230
RBST1102	1-1/2"	320
RBST1508	1-5/8"	350
RBST1304	1-3/4"	550
RBST1708	1-7/8"	650
RBST2000	2"	730



EYE BOLT AND EYE NUT

Regular Nut Eye Bolt H.D.G., forged carbon steel G291

Part No.	Size inch	W.L.L. lbs	Thread Length inch	I.D. of Eye inch	N.W. lbs/100pcs
R9E20104	1/4 x 2	650	1.5	0.50	6.00
R9E40104	1/4 x 4	650	2.5	0.50	13.50
R9E20516	5/16 x 2-1/4	1200	1.5	0.62	18.75
R9E40516	5/16 x 4-1/4	1200	2.5	0.62	25.00
R9E20308	3/8 x 2-1/2	1550	1.5	0.75	24.33
R9E40308	3/8 x 4-1/2	1550	2.5	0.75	37.50
R9E60308	3/8 x 6	1550	2.5	0.75	43.75
R9E30102	1/2 x 3-1/4	2600	1.5	1.00	50.00
R9E60102	1/2 x 6	2600	3.0	1.00	62.50
R9E80102	1/2 x 8	2600	3.0	1.00	75.00
R9E00102	1/2 x 10	2600	3.0	1.00	88.00
R9E20102	1/2 x 12	2600	3.0	1.00	100.00
R9E40508	5/8 x 4	5200	2.0	1.25	101.25
R9E60508	5/8 x 6	5200	3.0	1.25	120.00
R9E80508	5/8 x 8	5200	3.0	1.25	131.00
R9E00508	5/8 x 10	5200	3.0	1.25	162.50
R9E20508	5/8 x 12	5200	4.0	1.25	175.00
R9E40304	3/4 x 4-1/2	7200	2.0	1.50	185.90
R9E60304	3/4 x 6	7200	3.0	1.50	180.00
R9E80304	3/4 x 8	7200	3.0	1.50	200.00
R9E00304	3/4 x 10	7200	3.0	1.50	237.50
R9E20304	3/4 x 12	7200	4.0	1.50	251.94
R9E50304	3/4 x 15	7200	5.0	1.50	300.00
R9E50708	7/8 x 5	10600	2.5	1.75	275.00
R9E80708	7/8 x 8	10600	4.0	1.75	325.00
R9E20708	7/8 x 12	10600	4.0	1.75	400.00
R9E61000	1 x 6	13300	3.0	2.00	425.00
R9E91000	1 x 9	13300	4.0	2.00	452.00
R9E21000	1 x 12	13300	4.0	2.00	550.00
R9E81000	1 x 18	13300	7.0	2.00	650.00
R9E81104	1-1/4 x 8	21000	4.0	2.50	750.00
R9E21104	1-1/4 x 12	21000	4.0	2.50	900.00
R9E01104	1-1/4 x 20	21000	6.0	2.50	1150.00



M.B.S. IS 5 TIMES OF W.L.L.

Shoulder Type Nut Eye Bolt H.D.G., forged carbon steel G277

Part No.	Size inch	W.L.L. lbs	Thread Length inch	I.D. of Eye inch	N.W. lbs/100pcs
R7E20104	1/4 x 2	650	1.5	0.50	6.61
R7E40104	1/4 x 4	650	2.5	0.50	8.61
R7E20516	5/16 x 2-1/4	1200	1.5	0.62	12.50
R7E40516	5/16 x 4-1/4	1200	2.5	0.62	18.75
R7E20308	3/8 x 2-1/2	1550	1.5	0.75	19.00
R7E40308	3/8 x 4-1/2	1550	2.5	0.75	31.58
R7E30102	1/2 x 3-1/4	2600	1.5	1.00	37.50
R7E60102	1/2 x 6	2600	3.0	1.00	56.25
R7E40508	5/8 x 4	5200	2.0	1.25	75.00
R7E60508	5/8 x 6	5200	3.0	1.25	100.25
R7E40304	3/4 x 4-1/2	7200	2.0	1.50	125.00
R7E60304	3/4 x 6	7200	3.0	1.50	150.00
R7E50708	7/8 x 5	10600	2.5	1.75	225.00
R7E61000	1 x 6	13300	3.0	2.00	375.00
R7E91000	1 x 9	13300	4.0	2.00	429.00
R7E81104	1-1/4 x 8	21000	4.0	2.50	650.00
R7E21104	1-1/4 x 12	21000	4.0	2.50	775.00
R7E51102	1-1/2 x 15	24000	6.0	3.00	1425.00



M.B.S. IS 5 TIMES OF W.L.L.

EYE BOLT AND EYE NUT

Shoulder Type Machinery Eye Bolt S.C.or H.D.G., forged carbon steel G279

Part No.	Size inch	W.L.L. lbs	Thread Length inch	I.D.of Eye inch	N.W. lbs/100pcs
RMEB0104	1/4 x 1	650	1.00	0.88	3.20
RMEB0516	5/16 x 1-1/8	1200	1.13	1.12	6.20
RMEB0308	3/8 x 1-1/4	1550	1.25	1.38	12.50
RMEB0102	1/2 x 1-1/2	2600	1.50	1.75	25.00
RMEB0508	5/8 x 1-3/4	5200	1.75	2.25	50.00
RMEB0304	3/4 x 2	7200	2.00	2.75	87.50
RMEB0708	7/8 x 2-1/4	10600	2.25	3.25	150.00
RMEB1000	1 x 2-1/2	13300	2.50	3.75	218.00
RMEB1104	1-1/4 x 3	21000	3.00	4.50	380.00
RMEB1102	1-1/2 x 3-1/2	24000	3.50	5.50	700.00

M.B.S. IS 5 TIMES OF W.L.L.



Eye Nuts G400

- Forged Carbon Steel
- Quenched & Tempered
- Ultimate Load is 5 times the Working Load Limit.

Part No.	Std. tap Size inch	Dimensions(in.)								Max. tap Size Possible	W.L.L. (lbs)	Weight (lbs)
		A	C	D	E	F	S	T				
RUEN0104	1/4	1-1/4	3/4	1-1/16	21/32	1/2	1/4	1-11/16	3/8	520	0.09	
RUEN0516	5/16	1-1/4	3/4	1-1/16	21/32	1/2	1/4	1-11/16	3/8	850	0.09	
RUEN0308	3/8	1-5/8	1	1-1/4	3/4	9/16	5/16	2-1/16	7/16	1250	0.18	
RUEN0716	7/16	2	1-1/4	1-1/2	1	13/16	3/8	2-1/2	1/2	1700	0.29	
RUEN0102	1/2	2	1-1/4	1-1/2	1	13/16	3/8	2-1/2		2250	0.29	
RUEN0508	5/8	2-1/2	1-1/2	2	1-3/16	1	1/2	3-3/16	3/4	3600	0.58	
RUEN0304	3/4	3	1-3/4	2-3/8	1-3/8	1-1/8	5/8	3-7/8	7/8	5200	1.00	
RUEN0708	7/8	3-1/2	2	2-5/8	1-5/8	1-5/16	3/4	4-5/16	1	7200	1.70	
RUEN1000	1	4	2-1/4	3-1/16	1-7/8	1-9/16	7/8	5	1-1/4	10000	2.75	
RUEN1108	1-1/8	4	2-1/4	3-1/16	1-7/8	1-9/16	7/8	5	1-1/4	12300	2.75	
RUEN1104	1-1/4	4-1/2	2-1/2	3-1/2	1-15/16	1-7/8	1	5-3/4	1-1/2	15500	3.85	
RUEN1308	1-3/8	5	2-3/4	2-3/4	2	2	1-1/8	6-1/4	1-1/2	18500	5.00	
RUEN1102	1-1/2	5-5/8	3-1/8	4	2-3/8	2-1/4	1-1/4	6-3/4	1-3/4	22500	6.70	
RUEN2000	2	7	4	6-1/4	4	3-3/8	1-1/2	10	2-3/4	40000	18.70	

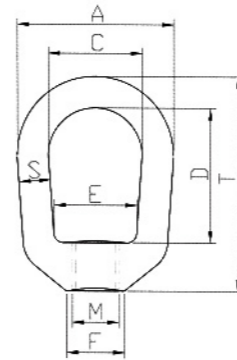

EYE BOLT AND EYE NUT

DIN580 Eye Bolt

Part No.	Size mm	W.L.L. (ton.)	N.W. kg/100pcs	Part No.	Size mm	W.L.L. (ton.)	N.W. kg/100pcs
R5EB0060	M6	0.07	5.00	R5EB0300	M30	3.6	166.00
R5EB0080	M8	0.14	6.00	R5EB0330	M33	4.3	172.00
R5EB0100	M10	0.23	11.00	R5EB0360	M36	5.1	265.00
R5EB0120	M12	0.34	18.00	R5EB0390	M39	6.1	280.00
R5EB0140	M14	0.49	28.50	R5EB0420	M42	7	403.00
R5EB0160	M16	0.7	28.00	R5EB0450	M45	8	425.00
R5EB0200	M20	1.2	45.00	R5EB0480	M48	8.6	638.00
R5EB0220	M22	1.5	67.00	R5EB0520	M52	9.9	660.00
R5EB0240	M24	1.8	78.00	R5EB0640	M64	11.5	880.00
R5EB0270	M27	2.5	88.00	R5EB0650	M65	16	1240.00



DIN582 Eye Nut

Part No.	Size mm	W.L.L. (ton.)	N.W. kg/100pcs	Part No.	Size mm	W.L.L. (ton.)	N.W. kg/100pcs
R5EN0060	M6	0.07	5.00	R5EN0240	M24	1.8	72.00
R5EN0080	M8	0.14	5.00	R5EN0270	M27	2.5	70.00
R5EN0100	M10	0.23	9.00	R5EN0300	M30	3.6	132.00
R5EN0120	M12	0.34	16.00	R5EN0330	M33	4.3	130.00
R5EN0160	M16	0.7	24.00	R5EN0360	M36	5.1	208.00
R5EN0200	M20	1.2	36.00	R5EN0390	M39	6.1	202.00
R5EN0220	M22	1.5	58.00				



Eye Bolt JIS B 1168, ZP

Part No.	Size mm	W.L.L. (kgs)	N.W. kgs
RJEB0080	8	80	0.035
RJEB0100	10	150	0.065
RJEB0120	12	200	0.13
RJEB0160	16	450	0.25
RJEB0200	20	630	0.43
RJEB0240	24	950	0.85
RJEB0300	30	1500	1.5



Eye Nut JIS B 1169, ZP

Part No.	Size mm	W.L.L. (kgs)	N.W. kg/100pcs
RJEN0080	8	80	0.035
RJEN0100	10	150	0.065
RJEN0120	12	220	0.13
RJEN0160	16	450	0.25
RJEN0200	20	630	0.46
RJEN0240	24	950	0.87
RJEN0300	30	1500	1.50



HOOK

Clevis Grab Hooks

- H-330 Forged Carbon Steel.
- A-330 Forged Alloy Steel.
- Quenched & Tempered.
- Ultimate Load is 4 times the Working Load Limit.

Part No.		Chain Size inch	W.L.L. lbs		Dimensions inch					N.W. lbs
H-330	A-330		H-330	A-330	B	E	P	R		
RCGH0104	RCGA0104	1/4	2,600	3,500	0.36	0.40	0.38	1.97	0.40	
RCGH0516	RCGA0516	5/16	3,900	4,700	0.40	0.44	0.44	2.26	0.79	
RCGH0308	RCGA0308	3/8	5,400	7,100	0.48	0.50	0.47	2.63	1.00	
RCGH0716	RCGA0716	7/16	7,200	8,750	0.66	0.56	0.56	2.75	1.50	
RCGH0102	RCGA0102	1/2	9,200	12,000	0.75	0.66	0.63	3.19	2.22	
RCGH0508	RCGA0508	5/8	13,000	15,800	0.91	0.78	0.75	4.09	4.40	
RCGH0304	RCGA0304	3/4	20,200	24,700	0.94	0.94	0.88	4.63	6.50	

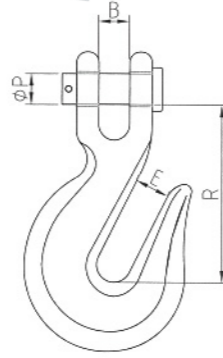

Clevis Slip Hooks

- H-331 Forged Carbon Steel.
- A-331 Forged Alloy Steel.
- Quenched & Tempered.
- Ultimate Load is 4 times the Working Load Limit.

Part No.		Chain Size inch	W.L.L. lbs		Dimensions inch					N.W. lbs
H-331	A-331		H-331	A-331	B	E	P	R		
RCSH0104	RCSA0104	1/4	1,950	2,750	0.44	0.94	0.38	2.56	0.53	
RCSH0516	RCSA0516	5/16	2,875	4,300	0.50	1.06	0.44	2.87	0.77	
RCSH0308	RCSA0308	3/8	4,000	5,250	0.59	1.31	0.47	3.25	1.20	
RCSH0716	RCSA0716	7/16	5,000	7,000	0.66	1.56	0.56	3.70	2.06	
RCSH0102	RCSA0102	1/2	6,500	9,000	0.75	1.69	0.63	4.00	2.80	
RCSH0508	RCSA0508	5/8	9,250	13,500	0.91	2.00	0.75	4.94	4.75	
RCSH0304	RCSA0304	3/4	12,500	19,250	1.31	2.50	1.00	6.09	11.15	

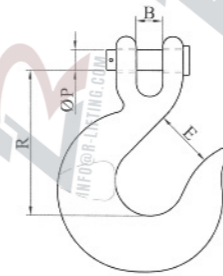

Clevis Slip Hooks With Latches

- Forged Carbon Steel or Alloy Steel.
- Quenched & Tempered.
- Ultimate Load is 4 times the Working Load Limit.

Part No.		Chain Size inch	W.L.L. lbs		Dimensions inch					N.W. lbs
H-331	A-331		H-331	A-331	B	E	P	R	T	
RCLC0104	RCLA0104	1/4	1,950	2,750	0.44	0.79	0.38	2.56	0.79	0.52
RCLC0516	RCLA0516	5/16	2,875	4,300	0.50	0.93	0.44	2.87	0.79	0.77
RCLC0308	RCLA0308	3/8	4,000	5,250	0.59	1.14	0.47	3.25	1.02	1.23
RCLC0716	RCLA0716	7/16	5,000	7,000	0.66	1.18	0.56	3.70	1.06	2.10
RCLC0102	RCLA0102	1/2	6,500	9,000	0.75	1.42	0.63	4.00	1.38	2.85
RCLC0508	RCLA0508	5/8	9,250	13,500	0.91	1.65	0.75	4.94	1.69	5.18
RCLC0304	RCLA0304	3/4	12,500	19,250	1.31	1.81	1.00	6.09	1.81	10.45
RCLC1000	RCLA1000	1	17,600	26,500	1.38	1.98	1.14	7.40	2.50	13.65

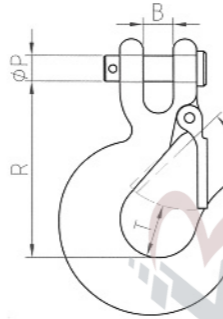

HOOK

Eye Grab Hooks

- H-323 Forged Carbon Steel.
- A-323 Forged Alloy Steel.
- Quenched & Tempered.
- Ultimate Load is 4 times the Working Load Limit.

Part No.		Chain Size inch	W.L.L. lbs		Dimensions inch			N.W. lbs
H-323	A-323		H-323	A-323	B	E	R	
REGH0104	REGA0104	1/4	2,600	3,500	0.50	0.34	1.97	0.28
REGH0516	REGA0516	5/16	3,900	4,700	0.56	0.44	2.25	0.45
REGH0308	REGA0308	3/8	5,400	7,100	0.66	0.50	2.56	0.79
REGH0716	REGA0716	7/16	7,200	8,750	0.75	0.56	2.94	1.19
REGH0102	REGA0102	1/2	9,200	12,000	0.88	0.66	3.38	1.80
REGH0508	REGA0508	5/8	13,000	15,800	1.06	0.78	4.11	3.30
REGH0304	REGA0304	3/4	20,200	24,700	1.38	0.94	5.16	6.00

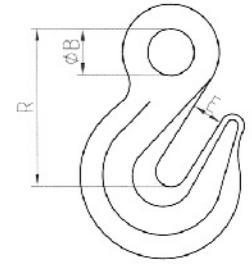

Eye Slip Hooks

- H-324 Forged Carbon Steel.
- A-324 Forged Alloy Steel.
- Quenched & Tempered.
- Ultimate Load is 4 times the Working Load Limit.

Part No.		Chain Size inch	W.L.L. lbs		Dimensions inch			N.W. lbs
H-324	A-324		H-324	A-324	B	E	R	
RESH0104	RESA0104	1/4	1,950	2,750	0.50	0.94	2.56	0.40
RESH0516	RESA0516	5/16	2,875	4,300	0.63	1.06	2.95	0.70
RESH0308	RESA0308	3/8	4,000	5,250	0.72	1.31	3.36	1.00
RESH0716	RESA0716	7/16	5,000	7,000	0.81	1.56	3.88	1.60
RESH0102	RESA0102	1/2	6,500	9,000	0.94	1.69	4.28	2.40
RESH0508	RESA0508	5/8	9,250	13,500	1.13	2.00	5.22	4.00
RESH0304	RESA0304	3/4	12,500	19,250	1.38	2.13	5.80	6.50

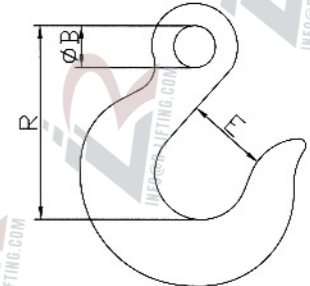

Eye Slip Hooks With Latches

- Forged Carbon Steel or Alloy Steel.
- Quenched & Tempered.
- Ultimate Load is 4 times the Working Load Limit.

Part No.		Chain Size inch	W.L.L. lbs		Dimensions inch				N.W. lbs
H-324	A-324		H-324	A-324	B	E	P	T	
RELH0104	RELA0104	1/4	1,950	2,750	0.50	0.75	2.56	0.79	0.42
RELH0516	RELA0516	5/16	2,875	4,300	0.63	0.88	2.95	0.79	0.72
RELH0308	RELA0308	3/8	4,000	5,250	0.72	1.10	3.36	1.02	1.03
RELH0716	RELA0716	7/16	5,000	7,000	0.81	1.25	3.88	1.06	1.64
RELH0102	RELA0102	1/2	6,500	9,000	0.94	1.38	4.28	1.30	2.45
RELH0508	RELA0508	5/8	9,250	13,500	1.13	1.45	5.22	1.53	4.13
RELH0304	RELA0304	3/4	12,500	19,250	1.38	1.59	5.80	1.62	6.76

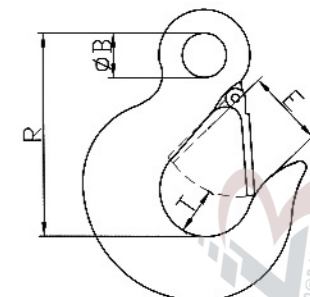

HOOK

Eye Hoist Hooks

- Forged, Quenched & Tempered.
- Proof Load is 2 times the Working Load Limit.
- Ultimate Load is 5 times the Working Load Limit.
- 320C—Carbon Steel; 320A—Alloy Steel.

Part No.		W.L.L. ton		Dimensions inch			N.W. lbs
320C	320A	320C	320A	B	E	R	
REHC0104	REHA0102	1/4	1/2	0.39	0.57	1.78	0.14
REHC0102	RESA0304	1/2	3/4	0.63	0.87	2.80	0.35
REHC0304	RESA1000	3/4	1	0.75	0.94	3.22	0.55
REHC1000	RESA1102	1	1-1/2	0.91	1.03	3.66	0.75
REHC1102	RESA2000	1-1/2	2	1.12	1.06	4.09	1.25
REHC2000	RESA3000	2	3	1.25	1.22	4.69	1.70
REHC3000	RESA5000	3	4-1/2	1.56	1.50	5.78	3.60
REHC5000	RESA7000	5	7	2.00	1.88	7.38	7.08
REHC7102	RESAT110	7-1/2	11	2.44	2.25	9.06	13.00
REHCT100	RESAT150	10	15	2.83	2.52	10.09	22.00
REHCT150	RESAT220	15	22	3.50	3.40	12.53	39.50

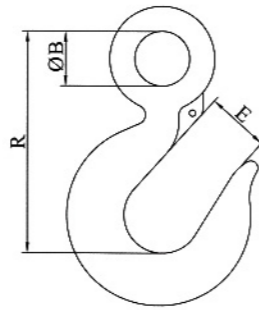

Eye Hoist Hooks With Latches

- Forged, Quenched & Tempered.
- Proof Load is 2 times the Working Load Limit.
- Ultimate Load is 5 times the Working Load Limit.
- 320C—Carbon Steel; 320A—Alloy Steel.

Part No.		W.L.L. ton		Dimensions inch					N.W. lbs
320C	320A	320C	320A	B	E	R	T		
RHLC0104	RHLA0102	1/4	1/2	0.39	0.40	1.78	0.49	0.16	
RHLC0102	RHLA0304	1/2	3/4	0.63	0.81	2.80	0.65	0.37	
RHLC0304	RHLA1000	3/4	1	0.75	0.88	3.22	0.81	0.57	
RHLC1000	RHLA1102	1	1-1/2	0.91	0.97	3.66	0.84	0.77	
RHLC1102	RHLA2000	1-1/2	2	1.12	1.00	4.09	0.84	1.28	
RHLC2000	RHLA3000	2	3	1.25	1.12	4.69	1.19	1.76	
RHLC3000	RHLA5000	3	4-1/2	1.56	1.34	5.78	1.38	3.66	
RHLC5000	RHLA7000	5	7	2.00	1.69	7.38	1.78	7.19	
RHLC7102	RHLAT110	7-1/2	11	2.44	2.06	9.06	2.12	13.17	
RHLCT100	RHLAT150	10	15	2.83	2.22	10.09	2.72	22.15	
RHLCT150	RHLAT220	15	22	3.50	3.02	12.53	2.83	39.55	

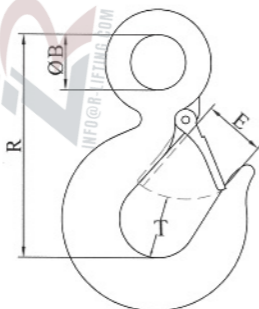

Shank Hooks

- Forged Carbon Steel or Alloy Steel.
- Proof Load is 2 times the Working Load Limit.
- Ultimate Load is 5 times the Working Load Limit.
- 319C—Carbon Steel; 319A—Alloy Steel.

Part No.		W.L.L. ton		Dimensions inch				N.W. lbs
319C	319A	319C	319A	A	B	E	R	
RSHC0304	RSHA1000	3/4	1	0.59	2.00	0.94	2.28	0.50
RSHC1000	RSHA1102	1	1-1/2	0.66	2.25	1.03	2.53	0.75
RSHC1102	RSHA2000	1-1/2	2	0.72	2.50	1.06	2.69	1.00
RSHC2000	RSHA3000	2	3	0.88	2.75	1.22	3.06	1.85
RSHC3000	RSHA5000	3	4-1/2	1.16	3.25	1.50	3.78	3.85
RSHC5000	RSHA7000	5	7	1.41	3.75	1.88	4.75	7.25
RSHC7102	RSHAT110	7-1/2	11	1.69	4.25	2.25	5.88	13.00
RSHCT100	RSHAT150	10	15	1.75	4.50	2.52	6.41	19.40

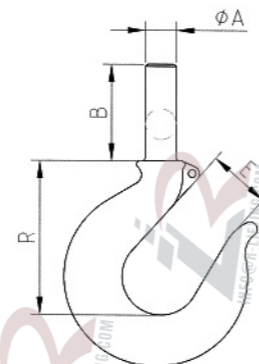

HOOK

Shank Hooks With Latches

- Forged, Quenched & Tempered.
- Proof Load is 2 times the Working Load Limit.
- Ultimate Load is 5 times the Working Load Limit.
- 319C—Carbon Steel; 319A—Alloy Steel.

Part No.		W.L.L. ton		Dimensions inch					N.W. lbs
319C	319A	319C	319A	A	B	O	R	T	
RSLC0304	RSLA1000	3/4	1	0.59	2.00	0.88	2.28	0.81	0.52
RSLC1000	RSLA1102	1	1-1/2	0.66	2.25	0.97	2.53	0.81	0.77
RSLC1102	RSLA2000	1-1/2	2	0.72	2.50	1.00	2.69	0.84	1.03
RSLC2000	RSLA3000	2	3	0.88	2.75	1.12	3.06	1.19	1.88
RSLC3000	RSLA5000	3	4-1/2	1.16	3.25	1.34	3.78	1.38	3.91
RSLC5000	RSLA7000	5	7	1.41	3.75	1.69	4.75	1.78	7.36
RSLCT102	RSLAT110	7-1/2	11	1.69	4.25	2.06	5.88	2.12	13.17
RSLCT100	RSLAT150	10	15	1.75	4.50	2.28	6.41	2.52	19.55

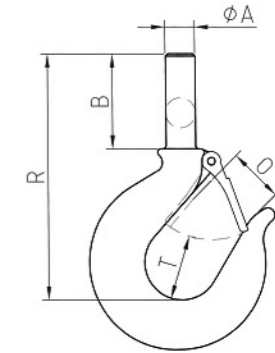

Swivel Hooks

- Forged, Quenched & Tempered.
- Proof Load is 2 times the Working Load Limit.
- Ultimate Load is 5 times the Working Load Limit.
- 322C—Carbon Steel.
- 322A—Hook Alloy Steel; Bail: Carbon Steel.

Part No.		W.L.L. ton		Dimensions inch					N.W. lbs
322C	322A	322C	322A	B	C	E	R	S	
RWHC0304	RWHA1000	3/4	1	15/16	1-1/4	15/16	4-15/32	3/8	0.75
RWHC1000	RWHA1102	1	1-1/2	1-5/16	1-1/2	1-1/32	5-9/32	1/2	1.25
RWHC1102	RWHA2000	1-1/2	2	1-5/8	1-3/4	1-1/16	6-1/64	5/8	2.25
RWHC2000	RWHA3000	2	3	1-9/16	1-3/4	1-7/32	6-3/8	5/8	2.57
RWHC3000	RWHA5000	3	4-1/2	1-3/4	2	1-1/2	7-13/32	3/4	4.75
RWHC5000	RWHA7000	5	7	2-5/16	2-1/2	1-7/8	9-19/32	1	10.29
RWHCT102	RWHAT110	7-1/2	11	2-3/8	2-3/4	2-1/4	11-1/8	1-1/8	16.25
RWHCT100	RWHAT150	10	15	2-13/16	3-1/8	2-1/2	11-15/16	1-1/4	23.25
RWHCT150	RWHAT220	15	22	4	4	3-2/5	16-5/6	1-1/2	54.20

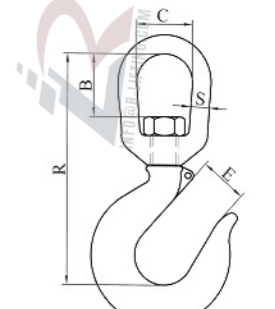

Swivel Hooks With Latches

- Forged, Quenched & Tempered.
- Proof Load is 2 times the Working Load Limit.
- Ultimate Load is 5 times the Working Load Limit.
- 322C—Carbon Steel.
- 322A—Hook Alloy Steel; Bail: Carbon Steel.

Part No.		W.L.L. ton		Dimensions inch						N.W. lbs
322C	322A	322C	322A	B	C	O	R	S	T	
RWLC0304	RWLA1000	3/4	1	15/16	1-1/4	7/8	4-15/32	3/8	13/16	0.77
RWLC1000	RWLA1102	1	1-1/2	1-5/16	1-1/2	31/32	5-9/32	1/2	13/16	1.27
RWLC1102	RWLA2000	1-1/2	2	1-5/8	1-3/4	1	6-1/64	5/8	27/32	2.28
RWLC2000	RWLA3000	2	3	1-9/16	1-3/4	1-1/8	6-3/8	5/8	1-3/16	2.60
RWLC3000	RWLA5000	3	4-1/2	1-3/4	2	1-11/32	7-13/32	3/4	1-3/8	4.81
RWLC5000	RWLA7000	5	7	2-5/16	2-1/2	1-11/16	9-19/32	1	1-25/32	10.40
RWLCT102	RWLAT110	7-1/2	11	2-3/8	2-3/4	2-1/16	11-1/8	1-1/8	2-1/8	16.42
RWLCT100	RWLAT150	10	15	2-13/16	3-1/8	2-1/4	11-15/16	1-1/4	2-1/2	23.40
RWLCT150	RWLAT220	15	22	4	4	2-1/32	16-5/6	1-1/2	2-5/6	54.90

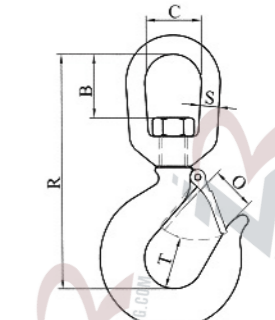

HOOK

Welded Hooks

- Forged Carbon Steel.
- Quenched & Tempered.
- Ultimate Load is 4 times the Working Load Limit.

Part No.	Size inch	W.L.L. lbs	Dimensions mm			N.W. kgs
			E	L	R	
RUWH0516	5/16	3,900	11	54	31	0.19
RUWH0308	3/8	9,200	16.5	85	44	0.86
RUWH0102	1/2	12,750	20.5	102	51	1.23

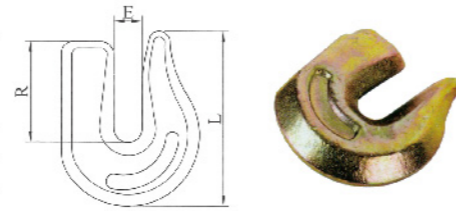

"T" Shank Hook

- Forged Carbon Steel.
- Quenched & Tempered.

Part No.	Size inch	Dimensions mm			N.W. kgs
		A	D	L	
RTSH0516	5/16	41	15.9	101	0.22



"R" Hook

- Forged Carbon or Alloy Steel.
- Quenched & Tempered.

Part No.	Chain Size inch	Dimensions inch				M.B.S. lbs		N.W. lbs
		A	B	L	M	Carbon	Alloy	
RRHC0516	5/16	1.14	0.56	3.37	2.64	11,700	18,800	0.66



"T" Hook

- Forged Carbon or Alloy Steel.
- Quenched & Tempered.

Part No.	Chain Size inch	Dimensions inch			M.B.S. lbs		N.W. lbs
		A	B	L	Carbon	Alloy	
RTHC0516	5/16	1.14	0.56	3.98	15,600	18,800	0.57

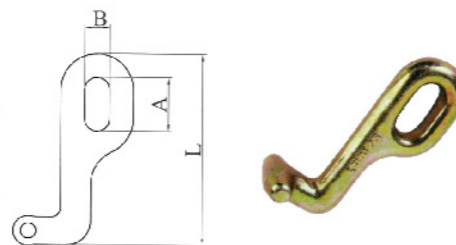

"T-J" Hook

- Forged Carbon or Alloy Steel.
- Quenched & Tempered.

Part No.	Chain Size inch	M.B.S. lbs		Dimensions inch				N.W. lbs
		Carbon	Alloy	A	B	L	LT	
RTJC0516	5/16	11,700	15,600	28.5	12.7	114	100.5	0.32

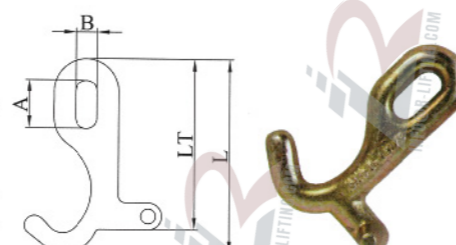

90° T-J Hook

- Forged Alloy Steel.
- Quenched & Tempered.

Part No.	Chain Size inch	Dimensions inch			M.B.S. lbs		N.W. kgs
		A	B	L	'T' Part	'J' Part	
R9TJ0516	5/16	28	14.4	101	15,600	11,200	0.35

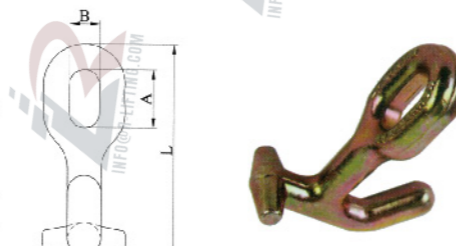

HOOK

Small J Hook

- Forged Alloy Steel.
- Quenched & Tempered.

Part No.	Size inch	M.B.S. lbs	Dimensions mm		N.W. kgs
			B	L	
RSJH0516	5/16-3/8	18,800	14.5	106	0.32



Cluster Hook R-T-J Single Ring

- Part No. RJRS0516
- Hooks Forged Carbon Steel.
- Quenched & Tempered.
- Ultimate Load: 11,700 Lbs.
- Weight: 0.96kgs



Cluster Hook R-T-J Double Ring

- Part No. RJRD0516
- Hooks Forged Carbon Steel.
- Quenched & Tempered.
- Ultimate Load: 11,700 Lbs.
- Weight: 1.15kgs



J Type Hooks With Ellipse Holes

- Forged Alloy Steel.
- Quenched & Tempered.
- Ultimate Load is 4 times the Working Load Limit.

Part No.	Size inch	Dimensions mm				M.B.S. lbs	N.W. kgs
		A	B	R	V		
RJTH8000	8	32	19.5	162	146	5,400	1.15
RJTHT150	15	32	19.5	319	146	5,400	1.76

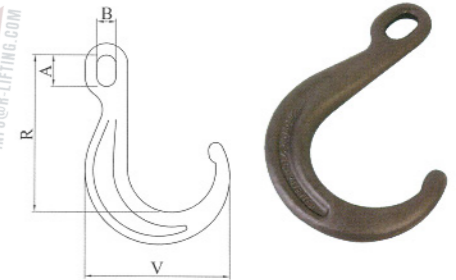

Eye Falcate Hooks

- Forged Alloy Steel.
- Quenched & Tempered.

Part No.	Dimensions inch				M.B.S. lbs	N.W. lbs
	B	D	L	R		
REFHA000	0.55	0.55	1.86	3.35	15,600	0.55
REFHB000	0.56	0.59	1.92	3.21	18,800	0.66

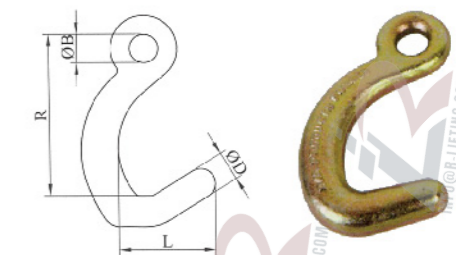

Long Falcate Hooks S Type

- Quenched & Tempered.

Part No.	Dimensions inch				M.B.S. lbs	N.W. lbs
	D	E	L	R		
RSFHA000	0.57	0.46	1.85	3.38	12,600	0.70
RSFHB000	0.57	0.46	1.85	3.38	15,600	0.79
RSFHC000	0.78	0.47	1.85	3.40	18,800	1.00

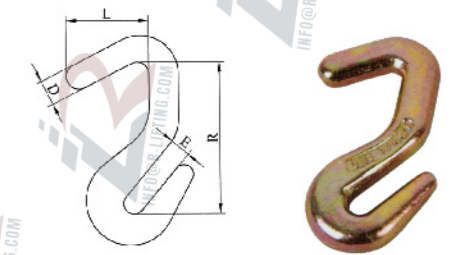

Twin Clevis Links

- Body is Forged Carbon Steel or Alloy steel, Heat Treated.
- Pins made from Alloy Steel, Quenched & Tempered.
- Ultimate Load is 4 times the Working Load Limit.

Part No.		Chain size (inch.)	W.L.L. (lbs.)	Dimensions				Weight (lbs.)
Carbon	Alloy			A	D	G	R	
RTCC0104	RTCA0104	1/4-5/16	4700	0.47	0.38	0.43	1.18	0.32
RTCC0308	RTCA0308	3/8	6600	0.53	0.47	0.48	1.34	0.44
RTCC0716	RTCA0716	7/16-1/2	11250	0.65	0.56	0.63	1.75	1.00
RTCC0508	RTCA0508	5/8	16500	0.78	0.69	0.75	2.12	1.32

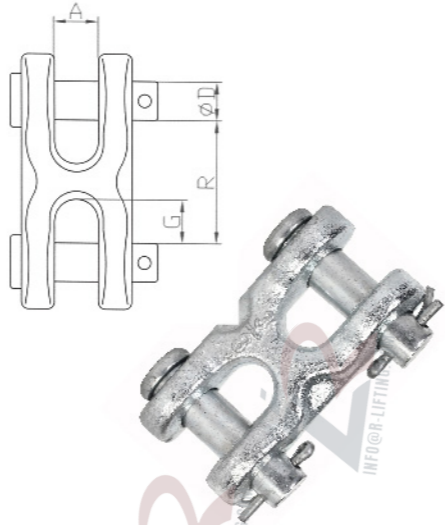

Double Clevis Links

- Forged Carbon Steel or Alloy Steel.
- Quenched & Tempered
- Ultimate Load is 4 times the Working Load Limit.

Part No.		Chain size (inch.)	W.L.L. (lbs.)	Dimensions								Weight (lbs.)
Carbon	Alloy			A	B	C	D	E	F	R		
RDCC0104	RDCA0104	1/4	2600	0.50	0.75	0.50	0.31	0.38	0.75	1.50	0.44	
RDCC0516	RDCA0516	5/16-3/8	5400	0.56	1.00	0.63	0.44	0.47	1.00	1.81	0.81	
RDCC0716	RDCA0716	7/16	7000	0.69	1.13	0.69	0.56	0.59	1.09	2.19	1.28	
RDCC0102	RDCA0102	1/2	9200	0.81	1.25	0.75	0.63	0.66	1.25	2.47	1.68	
RDCC0508	RDCA0508	5/8	17500	0.78	1.63	1.00	0.75	0.83	1.51	3.03	2.91	

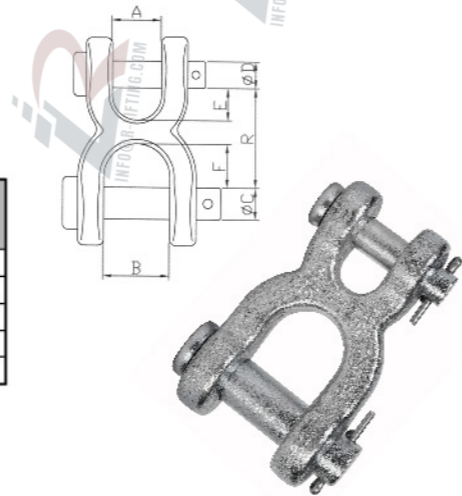

Weldless Alloy Master Links

- Forged Alloy Steel
- Quenched & Tempered
- Minimum Ultimate Load is 5 times the Working Load Limit.

Part No.	Size (inch.)	Inside Length (inch.)	Inside Width (inch.)	Weight (lbs.)	W.L.L. [Single Pull] (lbs.)	Proof Load (lbs)
RAML0102	1/2	5	2-1/2	0.89	7000	14000
RAML0508	5/8	6	3	1.63	9000	18000
RAML0304	3/4	5-1/2	2-3/4	2.25	12300	28400
RAML0708	7/8	7	3-1/2	3.53	15000	30000
RAML1000	1	7	3-1/2	5.00	24360	48700
RAML1104	1-1/4	8-3/4	4-3/8	9.75	36200	72400
RAML1102	1-1/2	10-1/2	5-1/4	17.12	54300	112200
RAML1304	1-3/4	12	6	26.12	84900	169800
RAML2000	2	14	7	38.00	102600	205200



Weldless Rings

- Forged Carbon Steel
 - Quenched & Tempered
- Ultimate Load is 5 times the Working Load Limit.

Part No.	Dimensions (inch)		Weight (lbs)	W.L.L. [Single Pull] (lbs)
	A	B		
RFR20308	3/8	2	0.23	2200
RFRA0308	3/8	2-1/4	0.26	2200
RFR30308	3/8	3-1/2	0.37	2200
RFR20102	1/2	2	0.44	2200
RFR30102	1/2	3	0.62	2200
RFRA0102	1/2	3-1/2	0.71	2200
RFR20508	5/8	2-1/2	0.86	3300
RFR30508	5/8	3	1.00	3300
RFRA0508	5/8	3-5/16	1.08	3300
RFR40508	5/8	4	1.28	3300
RFR30304	3/4	3	1.63	3700
RFRA0304	3/4	3-1/2	1.68	3700
RFR40304	3/4	4	1.89	3700
RFR30708	7/8	3-1/2	2.34	7200
RFR40708	7/8	4	2.70	7200
RFR50708	7/8	5-1/2	3.47	5600
RFR41000	1	4	3.69	10800
RFR51000	1	5-1/2	4.54	10800
RFR61000	1	6	4.85	10800
RFR61108	1-1/8	6	6.60	10800
RFR51104	1-1/4	5	7.00	17000
RFRA1104	1-1/4	5-1/2	7.41	17000
RFR61104	1-1/4	6	7.94	17000
RFR61308	1-3/8	6	10.63	19000
RFR81102	1-1/2	8	14.95	22000

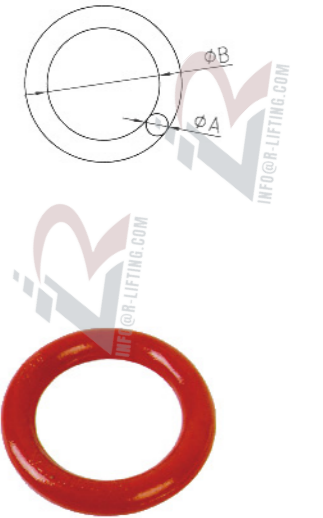

Weldless Pear Links

- Forged Carbon Steel or Alloy Steel.
- Quenched & Tempered.
- Ultimate Load is 5 times the Working Load Limit.

Part No.		Size (inch)	Inside Length (inch)	Inside Width (inch)		Weight (lbs)	W.L.L. [Single Pull] (lbs)	
Carbon	Alloy			Small End	Large End		Carbon	Alloy
RPLC0308	RPLA0308	3/8	2-1/4	3/4	1-1/2	0.23	1600	-
RPLC0102	RPLA0102	1/2	3	1	2	0.55	2900	7000
RPLC0508	RPLA0508	5/8	3-3/4	1-1/4	2-1/2	1.10	4200	9000
RPLC0304	RPLA0304	3/4	4-1/2	1-1/2	3	1.95	6000	12300
RPLC0708	RPLA0708	7/8	5-1/4	1-3/4	3-1/2	2.78	8300	14000
RPLC1000	RPLA1000	1	6	2	4	4.30	10800	24360
RPLC1104	RPLA1104	1-1/4	7-3/4	2-1/2	5	8.50	16750	36000
RPLC1308	RPLA1308	1-3/8	8-1/4	2-3/4	5-1/2	11.50	20500	43000
RPLC1102	RPLA1102	1-1/2	9	3	6	14.25	-	54300
RPLC1304	RPLA1304	1-3/4	10-1/2	3-1/2	7	22.50	-	84900
RPLC2000	RPLA2000	2	12	4	8	34.00	-	102600



Chain Swivel (G-401) Hot Dip Galvanized

- Forged Carbon Steel
- Quenched & Tempered

Ultimate Load is 5 times the Working Load Limit.

Part No.	Chain Size (inch.)	Dimensions(in.)					W.L.L. (lbs)	Weight (kgs)
		B	C	D	G	T		
R401S0104	1/4	0.69	0.75	0.62	0.25	3.00	850	0.06
R401S0516	5/16	0.81	1.00	0.72	0.31	3.59	1250	0.12
R401S0308	3/8	0.94	1.25	1.00	0.38	4.44	2500	0.25
R401S0102	1/2	1.31	1.50	1.25	0.50	5.69	3600	0.51
R401S0508	5/8	1.56	1.75	1.50	0.62	6.89	5200	0.95
R401S0304	3/4	1.75	2.00	1.75	0.75	7.84	7200	1.45
R401S0708	7/8	2.06	2.25	2.00	0.87	9.02	10000	2.30
R401S1000	1	2.31	2.50	2.25	1.00	10.24	12500	3.61
R401S1108	1-1/8	2.33	2.75	2.50	1.13	11.25	16500	5.45
R401S1104	1-1/4	2.66	3.13	2.75	1.25	12.15	18000	7.00
R401S1102	1-1/2	4.40	4.00	3.00	1.50	16.38	45200	15.04

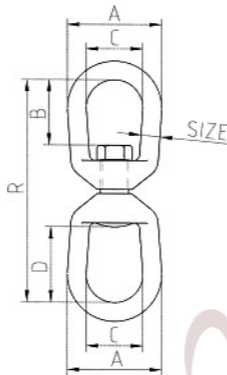
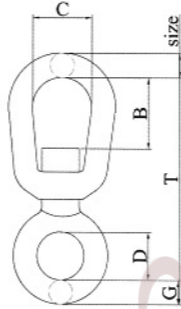

Regular Swivel G402

- Forged, Quenched & Tempered
- Hot Dip Galvanized.
- Ultimate Load is 5 times the Working Load Limit.

Part No.	S size (inch.)	Dimensions(in.)					W.L.L. (lbs)	Weight (lbs)
		A	B	C	D	R		
R402S0104	1/4	1-1/4	1-1/6	3/4	1-1/16	2-15/16	850	0.21
R402S0516	5/16	1-5/8	13/16	1	1-1/4	3-9/16	1250	0.39
R402S0308	3/8	2	15/16	1-1/4	1-1/2	4-5/16	2250	0.75
R402S0102	1/2	2-1/2	1-5/16	1-1/2	2	5-7/16	3600	1.43
R402S0508	5/8	3	1-9/16	1-3/4	2-3/8	6-9/16	5200	2.50
R402S0304	3/4	3-1/2	1-3/4	2	2-5/8	7-3/16	7200	4.13
R402S0708	7/8	4	2-1/16	2-1/4	3-1/16	8-3/8	10000	6.25
R402S1000	1	4-1/2	2-5/16	2-1/2	3-1/2	9-5/8	12500	9.00
R402S1108	1-1/8	5	2-3/8	2-3/4	3-3/4	7-7/32	16500	11.00
R402S1104	1-1/4	5-5/8	2-11/16	3-1/8	2-11/16	11-1/8	18000	16.37
R402S1102	1-1/2	7	4-3/16	4	4-3/16	17-1/8	45200	49.06

Jaw End Swivels G403

- Forged, Quenched & Tempered
- Hot Dip Galvanized.
- Ultimate Load is 5 times the Working Load Limit.

Part No.	Size (Inch.)	Dimensions(in.)							W.L.L. (lbs)	Weight (lbs)
		B	C	K	M	N	P	R		
R403S0104	1/4	0.69	0.75	0.47	0.31	0.88	0.25	2.63	850	0.21
R403S0516	5/16	0.81	1.00	0.50	0.38	0.88	0.31	2.94	1250	0.34
R403S0308	3/8	0.94	1.25	0.63	0.50	1.06	0.38	3.63	2250	0.66
R403S0102	1/2	1.31	1.50	0.75	0.63	1.31	0.50	4.50	3600	1.34
R403S0508	5/8	1.56	1.75	0.94	0.75	1.50	0.63	5.31	5200	2.48
R403S0304	3/4	1.75	2.00	1.13	0.88	1.75	0.75	6.06	7200	3.88
R403S0708	7/8	2.06	2.25	1.19	1.00	2.06	0.88	7.00	10000	5.87
R403S1000	1	2.31	2.50	1.75	1.13	2.81	1.13	8.56	12500	9.84
R403S1104	1-1/4	2.69	3.13	2.06	1.50	2.81	1.38	9.44	18000	15.75
R403S1102	1-1/2	4.19	4.00	2.88	2.25	4.44	2.25	14.74	45200	54.75

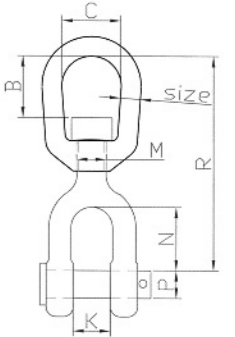

Malleable Cleat, Hot Dip Galvanized

Part No.	Size (inch.)	I.D. of Hole(mm)	N.W. (kg)
RMCT0040	4	6.0	0.106
RMCT0050	5	6.5	0.143
RMCT0060	6	7.9	0.170
RMCT0080	8	9.5	0.680
RMCT0100	10	11.1	0.936
RMCT0120	12	12.7	1.620
RMCT0140	14	14.3	2.670
RMCT0180	18	17.7	4.990



Repair Link, ZP

Part No.	Size (inch.)	O.L. (mm)	N.W. (kg/100pcs)
RRLK0108	1/8 x 3/4	19	0.60
RRLK0316	3/16 x 1	25	1.40
RRLK0732	7/32 x 1-1/4	32	2.30
RRLK0104	1/4 x 1-1/4	32	3.00
RRLA0104	1/4 x 1-1/2	38	3.60
RRLK0516	5/16 x 1-1/2	38	6.00
RRLK0308	3/8 x 1-5/8	42	10.00
RRL40308	3/8 x 2	50	11.00
RRLK0102	1/2 x 2-1/2	64	25.50



Cold Shut, ZP

Part No.	Size (inch.)	O.L. (mm)	W.L.L. lbs	N.W. (kg/100pcs)
RCST0316	3/16	22	1320	3.00
RCST0104	1/4	25	2200	4.00
RCST0516	5/16	30	3300	7.00
RCST0308	3/8	33	5500	9.00
RCST0916	9/16	38	6600	10.00
RCST0102	1/2	40	8800	18.00



SNAP HOOK

Snap Hook, Zinc Plated

Part No.	Size mm	A mm	B mm	C mm	D mm	F mm	W.L.L. lbs	N.W. kg/100pcs
RSHK0440	4X40	4	20	40	7	7	200	0.8
RSHK0550	5X50	5	25	50	8	7	220	1.6
RSHK0660	6X60	6	30	60	9	8	260	2.8
RSHK0770	7X70	7	35	70	10	8	400	4.5
RSHK0880	8X80	8	40	80	12	9	500	6.3
RSHK0990	9X90	9	45	90	12	10	550	9.4
RSHK1010	10X100	10	50	100	15	11	770	12.5
RSHK1112	11X120	11	57	120	18	16	990	19.2
RSHK1214	12X140	12	67	140	20	19	1200	25.8
RSHK1316	13X160	13	74	160	22	25	1400	35.1
RSHK1418	14X180	14	86	180	22	35	1600	45.5
RSHK1520	15X200	15	96	200	26	37	1800	61.8

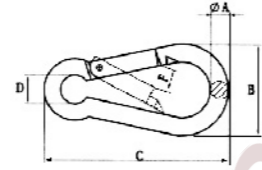

Snap Hook With Eyelet, Zinc Plated

Part No.	Size mm	A mm	B mm	C mm	D mm	F mm	W.L.L. lbs	N.W. kg/100pcs
RSHE0440	4X40	4	20	40	4	7	200	0.85
RSHE0550	5X50	5	25	50	5	7	220	1.80
RSHE0660	6X60	6	30	60	5	8	260	3.00
RSHE0770	7X70	7	35	70	7	8	400	5.00
RSHE0880	8X80	8	40	80	10	9	500	7.00
RSHE0990	9X90	9	45	90	12	10	550	9.80
RSHE1010	10X100	10	50	100	13	11	770	14.20
RSHE1112	11X120	11	57	120	13	16	990	21.00
RSHE1214	12X140	12	67	140	15	19	1200	27.50
RSHE1316	13X160	13	74	160	17	25	1400	35.80
RSHE1418	14X180	14	86	180	17	35	1600	46.30

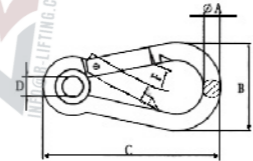

Snap Hook With Screw, Zinc Plated

Part No.	Size mm	A mm	B mm	C mm	D mm	F mm	W.L.L. lbs	N.W. kg/100pcs
RSHS0440	4X40	4	20	40	7	7	200	1.3
RSHS0550	5X50	5	25	50	8	7	220	2
RSHS0660	6X60	6	30	60	9	8	260	3
RSHS0770	7X70	7	35	70	10	8	400	5
RSHS0880	8X80	8	40	80	12	9	500	7.5
RSHS0990	9X90	9	45	90	12	10	550	9.8
RSHS1010	10X100	10	50	100	15	11	770	16
RSHS1112	11X120	11	57	120	18	16	990	21
RSHS1214	12X140	12	67	140	20	19	1200	27
RSHS1316	13X160	13	74	160	22	25	1400	36
RSHS1418	14X180	14	86	180	22	35	1600	51

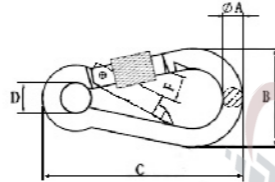

Snap Hook With Eyelet And Screw, Zinc Plated

Part No.	Size mm	A mm	B mm	C mm	D mm	F mm	W.L.L. lbs	N.W. kg/100pcs
RSES0550	5X50	5	25	50	5	7	220	2.1
RSES0660	6X60	6	30	60	5	8	260	3.22
RSES0770	7X70	7	35	70	7	8	400	5.04
RSES0880	8X80	8	40	80	10	9	500	7.7
RSES0990	9X90	9	45	90	12	10	550	9.9
RSES1010	10X100	10	50	100	13	11	770	16.2
RSES1112	11X120	11	57	120	13	16	990	22
RSES1214	12X140	12	67	140	15	19	1200	28
RSES1316	13X160	13	74	160	17	25	1400	37
RSES1418	14X180	14	86	180	17	35	1600	52

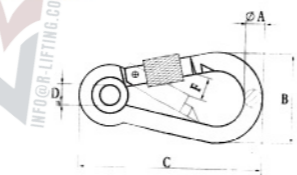

QUICK LINK

Quick Link, Zinc Plated

Part No.	Size mm	A mm	L1 mm	L2 mm	F mm	W.L.L. lbs	N.W. kg/100pcs
RQLK0035	3.5	3.5	36.5	17	5	200	0.80
RQLK0040	4	4	40	19.5	5.5	400	1.20
RQLK0050	5	5	49	23	6.5	660	2.10
RQLK0060	6	6	58	26.5	7.5	880	3.50
RQLK0070	7	7	65	30.5	8.5	1240	5.45
RQLK0080	8	8	75	33.5	10.5	1600	7.50
RQLK0090	9	9	82	35	11.5	2200	10.50
RQLK0100	10	10	90	40.5	12	2640	13.50
RQLK0110	11	11	99	44	13.5	3300	19.00
RQLK0120	12	12	107	47.5	14.5	3300	22.80
RQLK0140	14	14	125	54.5	17	6100	35.00
RQLK0160	16	16	144	61.5	20	8000	50.00

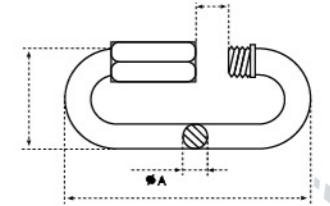

Wide Jaw Quick Link, Zinc Plated

Part No.	Size mm	A mm	L1 mm	L2 mm	F mm	W.L.L. lbs	N.W. kg/100pcs
RWQL0035	3.50	3.50	47.00	17.00	10	200	1.2
RWQL0050	5.00	5.00	62.00	23.00	14	550	2.5
RWQL0060	6.00	6.00	72.00	26.50	16	770	4.12
RWQL0080	8.00	8.00	90.00	33.50	18	1430	8.6
RWQL0100	10.00	10.00	105.00	40.50	20	1760	15.1
RWQL0120	12.00	12.00	122.00	47.50	23	2755	26.55

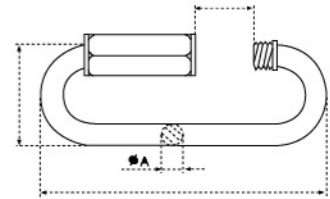

4 Times Of W.L.L. Quick Link, Zinc Plated

Part No.	Size mm	A mm	L1 mm	L2 mm	F mm	W.L.L. lbs	N.W. kg/100pcs
R4QL0035	3.5	3.5	36	17	5	220	0.8
R4QL0040	4	4	39.5	19.5	5.5	400	1.2
R4QL0050	5	5	48.5	23	6.5	660	2.1
R4QL0060	6	6	57	26.5	7.5	880	3.5
R4QL0070	7	7	66	30	8.5	1240	5.45
R4QL0080	8	8	74	33.5	10.5	1600	7.5
R4QL0090	9	9	80	37	11	2200	10.5
R4QL0100	10	10	89	40.5	12	2640	13.5
R4QL0120	12	12	104.5	47.5	15	3300	22.8
R4QL0140	14	14	121	54.5	17	6100	35
R4QL0160	16	16	140	61.5	19	8000	50

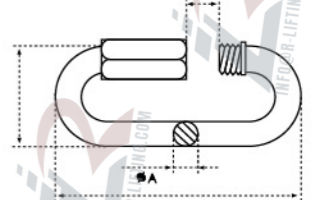

DIE CASTING PRODUCT

Die Casting Single Pulley, Zinc Alloy, Zinc Plated

Part No.	Size inch	Rope Dia. inch	N.W. kg/100pcs
RSPS0304	3/4	1/8	2.30
RSPL0304	3/4	3/16	2.40
RSPM1000	1	1/4	4.70
RSPS1102	1-1/2	5/16	10.70
RSPL1102	1-1/2	3/8	11.00
RSPS2000	2	3/8	20.50



Die Casting Double Pulley, Zinc Alloy, Zinc Plated

Part No.	Size inch	Rope Dia. inch	N.W. kg/100pcs
RDPS0304	3/4	1/8	3.60
RDPL0304	3/4	3/16	4.20
RDPM1000	1	1/4	7.70
RDPS1102	1-1/2	5/16	16.50
RDPL1102	1-1/2	3/8	17.00



Die Casting Single Pulley With Swivel, Zinc Alloy, Zinc Plated

Part No.	Size inch	Rope Dia. inch	N.W. kg/100pcs
RPSS0304	3/4	1/8	2.30
RPSL0304	3/4	3/16	2.40
RPSM1000	1	1/4	4.80
RPSS1102	1-1/2	5/16	11.00
RPSL1102	1-1/2	3/8	11.50
RPSM2000	2	3/8	21.00



Die Casting Double Pulley with Swivel

Part No.	Size inch	Rope Dia. inch	N.W. kg/100pcs
RDSS0304	3/4	1/8	4.00
RDSL0304	3/4	3/16	4.80
RDSM1000	1	1/4	8.00
RDSS1102	1-1/2	5/16	17.00
RDSL1102	1-1/2	3/8	17.50



STAINLESS STEEL PRODUCT

Stainless Steel Malleable Type Wire Rope Clip U.S. TYPE, a.i.s.i. 304 or 316

Part No.	Size inch	N.W. kg	Part No.	Size inch	N.W. kg
RSMC0108	1/8	0.02	RSMC0102	1/2	0.17
RSMC0316	3/16	0.03	RSMC0508	5/8	0.28
RSMC0104	1/4	0.06	RSMC0304	3/4	0.33
RSMC0516	5/16	0.07	RSMC0708	7/8	0.53
RSMC0308	3/8	0.12	RSMC1000	1	0.67



Stainless Steel Drop Forged Type Wire Rope Clip U.S. Type, a.i.s.i. 304 or 316

Part No.	Size inch	N.W. kg	Part No.	Size inch	N.W. kg
RSFC0108	1/8	0.023	RSFC0102	1/2	0.345
RSFC0316	3/16	0.041	RSFC0916	9/16	0.450
RSFC0104	1/4	0.083	RSFC0508	5/8	0.460
RSFC0516	5/16	0.142	RSFC0304	3/4	0.690
RSFC0308	3/8	0.193	RSFC0708	7/8	1.110
RSFC0716	7/16	0.325	RSFC1000	1	1.150



Stainless Steel Screw Pin Anchor Shackle U.S. Type, a.i.s.i. 304 or 316

Part No.	Size inch	W.L.L. lbs	PIN. DIA. inch	I.L. inch	N.W. kg
RSUA0316	3/16	300	1/4	7/8	0.021
RSUA0104	1/4	450	5/16	1-1/8	0.036
RSUA0516	5/16	650	3/8	1-7/32	0.077
RSUA0308	3/8	1000	7/16	1-7/16	0.138
RSUA0716	7/16	1450	1/2	1-11/16	0.175
RSUA0102	1/2	1990	5/8	1-7/8	0.261
RSUA0508	5/8	3050	3/4	2-3/8	0.552
RSUA0304	3/4	4475	7/8	2-13/16	1.020
RSUA0708	7/8	6000	1	3-5/16	1.600
RSUA1000	1	7950	1-1/8	3-3/4	2.400
RSUA1108	1-1/8	10500	1-1/4	4-1/4	3.140
RSUA1104	1-1/4	13600	1-3/8	4-11/16	4.380



STAINLESS STEEL PRODUCT

Stainless Steel Screw Pin Chain Shackle U.S. Type, a.i.s.i. 304 or 316

Part No.	Size inch	W.L.L. lbs	PIN. DIA. inch	I.L. inch	N.W. kg
RSUC0316	3/16	300	1/4	3/4	0.017
RSUC0104	1/4	450	5/16	7/8	0.030
RSUC0516	5/16	650	3/8	1-1/32	0.065
RSUC0308	3/8	1000	7/16	1-1/4	0.125
RSUC0716	7/16	1450	1/2	1-7/16	0.184
RSUC0102	1/2	1990	5/8	1-5/8	0.230
RSUC0508	5/8	3050	3/4	2	0.510
RSUC0304	3/4	4475	7/8	2-3/8	0.930
RSUC0708	7/8	6000	1	2-13/16	1.270
RSUC1000	1	7950	1-1/8	3-3/16	1.870
RSUC1108	1-1/8	10500	1-1/4	3-9/16	2.950
RSUC1104	1-1/4	13600	1-3/8	3-15/16	4.000



Stainless Steel Extra Heavy Duty Wire Rope Thimble U.S. Type, a.i.s.i. 304 or 316

Part No.	Size inch	N.W. kg	Part No.	Size inch	N.W. kg
RSHT0316	3/16	0.026	RSHT0916	9/16	0.240
RSHT0104	1/4	0.028	RSHT0508	5/8	0.330
RSHT0516	5/16	0.054	RSHT0304	3/4	0.690
RSHT0308	3/8	0.107	RSHT0708	7/8	0.830
RSHT0716	7/16	0.147	RSHT1000	1	1.200
RSHT0102	1/2	0.240			



Stainless Steel Standard Wire Rope Thimble U.S. Type, a.i.s.i. 304 or 316

Part No.	Size inch	N.W. kg	Part No.	Size inch	N.W. kg
RSLT0108	1/8	0.015	RSLT0102	1/2	0.060
RSLT0316	3/16	0.015	RSLT0508	5/8	0.167
RSLT0104	1/4	0.015	RSLT0304	3/4	0.262
RSLT0516	5/16	0.019	RSLT0708	7/8	0.403
RSLT0308	3/8	0.031	RSLT1000	1	0.476



Stainless Steel Rigging Screw With Jaw And Jaw, a.i.s.i. 304 or 316

Part No.	Size mm	W.L.L. lbs	Body Length mm	N.W. kg
RSRS0050	5	550	70	0.07
RSRS0060	6	825	80	0.08
RSRS0080	8	1625	90	0.17
RSRS0100	10	2350	100	0.26
RSRS0120	12	3500	140	0.44
RSRS0150	16	5250	200	1.08
RSRS0200	20	6875	230	2.00



STAINLESS STEEL PRODUCT

Stainless Steel Quick Link, a.i.s.i. 304 or 316

Part No.	Size inch	W.L.L. lbs	O.L. mm	N.W. kg/100pcs
RSQL0035	3.5	175	36.50	0.81
RSQL0040	4	500	40.00	1.22
RSQL0050	5	650	49.00	2.10
RSQL0060	6	875	58.00	3.55
RSQL0070	7	1200	65.00	6.60
RSQL0080	8	1525	75.00	7.61
RSQL0090	9	1975	82.00	11.17
RSQL0100	10	2300	90.00	13.70
RSQL0120	12	2500	107.00	25.38
RSQL0140	14	2800	125.00	35.80



Stainless Steel Snap Hook, a.i.s.i. 304 or 316

Part No.	Size inch	W.L.L. lbs	N.W. kg/100pcs
RSSH0440	4X40	80	0.82
RSSH0550	5X50	100	1.83
RSSH0660	6X60	140	2.84
RSSH0770	7X70	200	4.57
RSSH0880	8X80	250	7.11
RSSH0990	9X90	280	9.14
RSSH1010	10X100	400	14.62
RSSH1112	11X120	500	19.49
RSSH1214	12X140	600	27.41
RSSH1316	13X160	700	36.29
RSSH1418	140X180	900	50.00



Stainless Steel U.S. Type Shoulder Type Nut Eye Bolt, Drop Forged, a.i.s.i. 304 or 316

Part No.	Size inch	I.D. of Eye inch	Thread Length inch	N.W. kg/100pcs
HSB20104	1/4x2	0.50	1.50	3.00
HSB40104	1/4x4	0.50	2.50	4.00
HSB20516	5/16x2-1/4	0.62	1.50	5.70
HSB40516	5/16x4-1/4	0.62	2.50	8.50
HSB20308	3/8x2-1/2	0.75	1.50	8.60
HSB40308	3/8x4-1/2	0.75	2.50	14.30
HSB30102	1/2x3-1/4	1.00	1.50	17.00
HSB60102	1/2x6	1.00	3.00	25.50
HSB40508	5/8x4	1.25	2.00	34.00
HSB60508	5/8x6	1.25	3.00	45.50
HSB40304	3/4x4-1/2	1.50	2.00	56.70
HSB60304	3/4x6	1.50	3.00	68.00



STAINLESS STEEL PRODUCT

Stainless Steel Eye Screw DIN 580, a.i.s.i. 304 or 316

Part No.	Size mm	W.L.L. ton	N.W. kg
RS5B0060	6	0.07	0.05
RS5B0080	8	0.14	0.06
RS5B0100	10	0.23	0.11
RS5B0120	12	0.34	0.18
RS5B0160	16	0.70	0.32
RS5B0200	20	1.20	0.45
RS5B0240	24	1.80	0.76
RS5B0300	30	3.60	1.66



Stainless Steel Eye Nut DIN 582, a.i.s.i. 304 or 316

Part No.	Size inch	W.L.L. ton	N.W. kg
RS5N0060	6	0.07	0.049
RS5N0080	8	0.14	0.050
RS5N0100	10	0.23	0.090
RS5N0120	12	0.34	0.160
RS5N0160	16	0.70	0.240
RS5N0200	20	1.20	0.360
RS5N0240	24	1.80	0.720
RS5N0300	30	3.60	1.320



Stainless Steel Clevis Grab Hook, a.i.s.i. 304 or 316

Part No.	Chain Size inch	W.L.L. lbs	I.L. inch	N.W. lbs
RSCG0104	1/4	1250	1.79	0.37
RSCG0516	5/16	1800	2.14	0.64
RSCG0308	3/8	2500	2.46	0.90
RSCG0102	1/2	3600	3.20	1.94



MIN. BREAKING STRENGTH=4 x W.L.L.

Stainless Steel Eye Grab Hook, a.i.s.i. 304 or 316

Part No.	Chain Size inch	W.L.L. lbs	I.L. inch	N.W. lbs
RSEG0104	1/4	1250	2.50	0.28
RSEG0516	5/16	1800	2.78	0.51
RSEG0308	3/8	2500	3.23	0.76
RSEG0102	1/2	3600	4.10	1.60



MIN. BREAKING STRENGTH=4 x W.L.L.

G80 FITTING

G80 European Type Connecting Link

PART NO.	SIZE (mm)	WEIGHT /KG	WLL/T	B.L/T	A	L	K	H
8ECL0060	6	0.08	1.12	4.48	15	58	42	7
8ECL0070	7	0.145	1.5	6	19	71.8	54.8	8.5
8ECL0708	7/8	0.146	2	8	18	79.5	62.5	8.5
8ECL0080	8	0.16	2	8	18	79.5	60.5	8.5
8ECL0100	10	0.3	3.15	12.6	25	93	68	10.8
8ECL0130	13	0.7	5.3	21.2	29	117	87	15
8ECL0160	16	1.1	8	32	34.5	148	108.4	19.8
8ECL0180	18	1.84	10	40	38	154	112	21
8ECL1820	18/20	1.8	12.5	50	41	169.5	121.5	24
8ECL0220	22	3.2	15	60	48	193.5	141.5	26
8ECL0260	26	4.5	21.2	84.8	57.5	220	158	30
8ECL0320	32	9	31.5	126	67	281	205	37

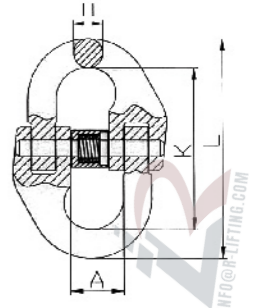

G80 U.S. Type Connecting Link

PART NO.	SIZE (inch)	WEIGHT /lbs	WLL/lbs	B.L/lbs	A	L	K	H
83370104	1/4	0.286	3500	14000	16.5	67	51	8
83370516	5/16	0.32	4500	18000	17	78.5	58.5	10
83370308	3/8	0.73	7100	28400	22	87.6	63.6	12
83370102	1/2	1.67	12000	48000	28.5	115.5	85.5	15
83370508	5/8	2.86	18100	72400	33	143	106	18.5
83370304	3/4	5	28300	113200	41	162	116	23
83370708	7/8	7.5	34200	136800	50.5	188.5	136.5	26
83371000	1	11.03	47700	190800	57	214.5	152.5	31
83371104	1-1/4	20.38	72300	289200	65	265	188.7	38

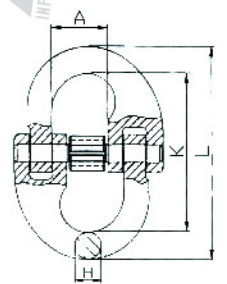

G80 European Type Eye Self-locking Hook

PART NO.	SIZE (mm)	WEIGHT /KG	WLL/T	B.L/T	Φ1	R	D	Φ2	H	E
8EHL0060	6	0.5	1.12	4.48	22	110.5	10	34	19.5	28
8EHL0708	7/8	0.8	2	8	25	136	12	46	24	34
8EHL0100	10	1.55	3.15	12.6	32	171	15	56	28.5	44
8EHL0130	13	3.2	5.3	21.2	40.5	208.5	19.5	69	40	52
8EHL0160	16	5.74	8	32	56	257.5	22	86	50.5	60
8EHL0200	20	8.5	12.5	50	64.5	275	27	100	55	81
8EHL0220	22	13	15	60	70	320	30	98	67	82
8EHL0260	26	18	21.2	84.8	80	363	34	110	75	110
8EHL0320	32	44.5	31.5	126	105	472	45	166	97	168

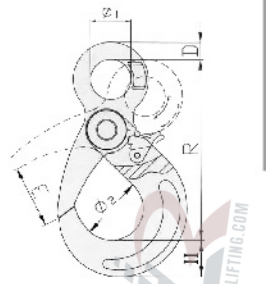

G80 European Type Clevis Self-locking Hook

PART NO.	SIZE (mm)	WEIGHT /KG	WLL/T	B.L/T	E	B	H	Φ	R
8CHL0060	6	0.5	1.12	4.48	29	8.5	19.5	34	95.5
8CHL0708	7/8	0.8	2	8	34	9.5	24	46	121
8CHL0100	10	1.5	3.15	12.8	44	12	28.5	56	146
8CHL0130	13	2.8	5.3	21.2	52	15	40	69	182
8CHL0160	16	5.6	8	32	60	18	50.5	86	218
8CHL0200	20	7.5	12.5	50	83	25	55	100	240
8CHL0220	22	11.5	15	60	88	25.5	67	98	276.5
8CHL0260	26	18.5	21.2	84.8	95.5	30	75	110	310.5

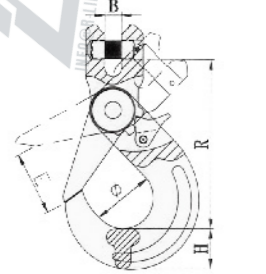

G80 FITTING

G80 European Swivel Self-locking Hook

PART NO.	SIZE (mm)	WEIGHT /KG	WLL/T	B.L/T	B	C	D	L	T	E
8SHL0060	6	0.71	1.12	4.48	32.5	22	11.25	170	34	29
8SHL0708	7/8	1.1	2	8	35.5	26	12.5	210	46	34
8SHL0100	10	2	3.15	12.6	42	34	15	247	56	44
8SHL0130	13	4	5.3	21.2	50	38.5	16	302	69	52
8SHL0160	16	7.3	8	32	61	55	21.5	383	86	60
8SHL0200	20	11.6	12.5	50	72	61	26	418	100	83
8SHL0220	22	16	15	60	95	95	33	527	98	88
8SHL0260	26	21.5	21.2	84.8	122	115	42	610	110	95.5
8SHL0320	32	79	31.5	126	140	146	52	777	166	150

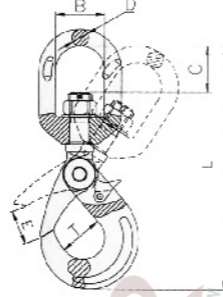

G80 Eye Grab Hook

PART NO.	SIZE (inch)	WEIGHT /lbs	WLL/ lbs	B.L/lbs	E	Φ	H	K	L
8EGH0104	1/4	0.6	3500	14000	10	15	23	64	98
8EGH0308	3/8	1.23	7100	28400	13	20.5	30	82	125
8EGH0102	1/2	3.05	12000	48000	16.5	25	42	106	165
8EGH0304	3/4	8.38	28300	113200	23.5	34.5	56	152	230
8EGH0708	7/8	11.9	34200	136800	23.5	34.5	56	152	230

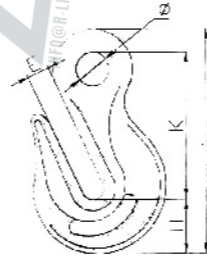

G80 Clevis Grab Hook

PART NO.	SIZE (inch)	WEIGHT /lbs	WLL/ lbs	B.L/ lbs	A	E	B	H	K	L
83380104	1/4	0.66	3500	14000	10	9.5	38	23	65.3	106.5
83380308	3/8	1.43	7100	28400	12.7	13	46	31	82	137
83380102	1/2	3.75	12000	48000	16.5	16.5	61	43	113	184.5
83380508	5/8	5.52	18100	72400	20	20	68.5	49	129.5	215
83380304	3/4	9.35	28300	113200	24	24	88	58	152	254
83380708	7/8	13.67	34200	136800	27.5	26.5	101	66	178	295

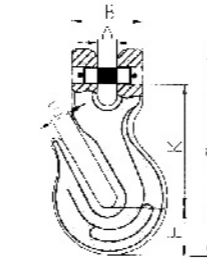

G80 Clevis Sling Hook With Latch

PART NO.	SIZE (mm)	WEIGHT /KG	WLL/T	B.L/T	A	B	Φ	H	K	E
8CSL0060	6	0.32	1.12	4.48	8	32	35	23	76	26
8CSL0708	7/8	0.52	2	8	9.5	37	37	32.5	85.5	29
8CSL0100	10	1.05	3.15	12.6	13	49	46	35	104	39
8CSL0130	13	2	5.3	21.2	16.5	56.5	56	42.5	128	47
8CSL0160	16	3.7	8	32	21.5	70.5	60	54	150	55
8CSL0200	20	6	12.5	50	24	77	79	58	180	61
8CSL0220	22	10.4	15	60	27	91	101	62	213	72

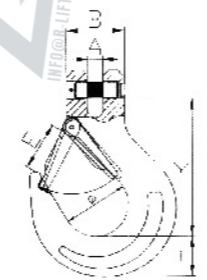

G80 FITTING

G80 Eye Sling Hook With Latch

PART NO.	SIZE (mm)	WEIGHT /KG	WLL/T	B.L/T	Φ1	E	D	Φ	L
8ESL0060	6	0.3	1.12	4.48	9	24	21	20	108
8ESL0708	7/8	0.4	2	8	11	30	26	25	133
8ESL0100	10	0.9	3.15	12.6	15	34	39	38	167
8ESL0130	13	1.7	5.3	21.2	19	39	54	43	213
8ESL0160	16	3.2	8	32	23	46	64	50	255
8ESL0200	20	5.8	12.5	50	24	40	80	62	305
8ESL0220	22	8.5	15	60	32	71	80	62	348
8ESL0260	26	13	21.2	84.8	35	81	82	64	394
8ESL0320	32	17	31.5	126	37	102	112	88	480

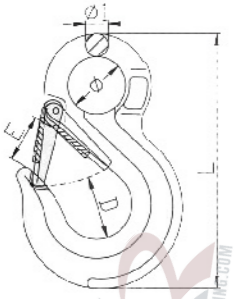

G80 Eye Foundry Type

PART NO.	SIZE (inch)	WEIGHT /lbs	WLL/lbs	B.L/lbs	E	Φ	L
8EFT0104	1/4	2.4	3500	14000	63.5	18	163
8EFT0308	3/8	4.5	7100	28400	76	22	200
8EFT0102	1/2	7.1	12000	48000	89	27	238
8EFT0508	5/8	12.2	18100	72400	102	32	278
8EFT0304	3/4	19.3	28300	113200	114.5	38	325
8EFT0708	7/8	26.3	34200	136800	127.5	45	361

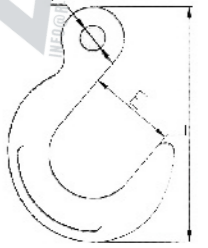

G80 Eye Shortening Grab Hook

PART NO.	SIZE (mm)	WEIGHT /KG	WLL/T	B.L/T	E	Φ	H	R	L
8ESG0060	6	0.14	1.12	4.48	8	13.5	16	51	75.2
8ESG0708	7/8	0.245	2	8	10.8	17	18.5	60.5	88.5
8ESG0100	10	0.65	3.15	12.6	13	20	29	79.5	121.5
8ESG0130	13	1.39	5.3	21.2	16.5	26	42.8	99.7	158
8ESG0160	16	2.2	8	32	19.2	30	45.7	104	169
8ESG0200	20	4.6	12.5	50	24	37	56	140	219
8ESG0220	22	8.2	15	60	28	44	68	165	259
8ESG0260	26	9.8	21.2	84.8	30	41	77	188.5	298
8ESG0320	32	19.4	31.5	126	38	57	95	228	361

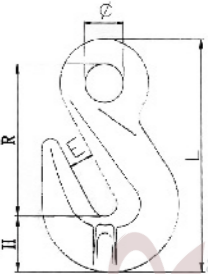

G80 Clevis Shortening Grab Hook

PART NO.	SIZE (mm)	WEIGHT /KG	WLL/T	B.L/T	E	A	H	L
8CSG0060	6	0.25	1.12	4.48	8	8	16	75
8CSG0708	7/8	0.32	2	8	10.8	9.5	21.6	90
8CSG0100	10	0.73	3.15	12.6	13.5	12.5	30	126
8CSG0130	13	1.6	5.3	21.2	16.5	15	42.5	163.5
8CSG0160	16	2.8	8	32	19.2	19.5	45.5	183.5
8CSG0200	20	5	12.5	50	24	24	56	219
8CSG0220	22	6.3	15	60	27	27	68.5	254

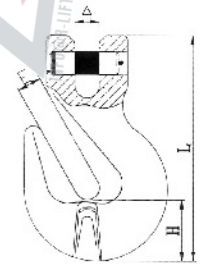

G80 FITTING

G80 Sliding Choke Hook

PART NO.	SIZE (inch)	WEIGHT /KG	WLL/T	B.L/T	Φ	A	B	E	L
8SCH3812	3/8-1/2	0.68	1.6	8	17	50	71	21	132
8SCH0508	5/8	1.21	2	10	22	63.5	79	23	151.5
8SCH0304	3/4	1.99	3	15	28	69	103	29	170
8SCH1000	1	4.18	5	25	32.5	85.7	105	38	213

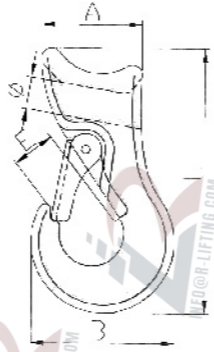

G80 Clevis Chain Clutch

PART NO.	SIZE (mm)	WEIGHT /KG	WLL/T	B.L/T	A	B	C	E	L
8CCC0060	6	0.17	1.12	4.48	7.5	7.5	33	26	73.5
8CCC0708	7/8	0.41	2	8	9.5	9.5	45	36	101
8CCC0100	10	0.97	3.15	12.6	13	13	55	48	138
8CCC0130	13	2.01	5.3	21.2	18	16	75	59	177
8CCC0160	16	3.32	8	32	21	21	93	73	220
8CCC1820	18/20	6.2	12.5	50	22	22	99	78	238
8CCC0220	22	8.5	15	60	25.5	25.5	118	98	295

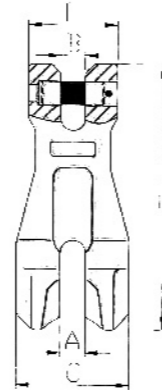

G80 Omega Link

PART NO.	SIZE (mm)	WEIGHT /KG	WLL/T	B.L/T	A	B	Φ	H	L
8OLS0060	6	0.12	1.12	4.48	8	41	20.5	25	52
8OLS0708	7/8	0.22	2	8	10	52	23.5	35	68.5
8OLS0100	10	0.36	3.15	12.6	12	62	31.5	40.5	81
8OLS0130	13	0.71	5.3	21.2	15	81	41	54	108
8OLS0160	16	1.3	8	32	19	99	49.5	64	126
8OLS0200	20	2.2	12.5	50	23	118	58	75.6	152

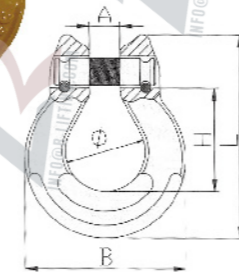

G80 FITTING

Cpd(A-346) (Wa-w) Master Link Assembly (No Flat DIN5688 Master Link)

PART NO.	SIZE (mm)	WEIGHT /KG	WLL/T	B.L/T	A	B	D	a	b	d	s	H
83460060	6	1.18	2.36	9.44	135	75	18	54	25	13	7	25
83460070	7	1.24	3.15	12.6	135	75	18	60	38	13	7	25
83460080	8	2.2	4.25	17	160	90	22	70	34	16	7	25
83460100	10	3.4	6.7	26.8	180	100	26	85	40	18	11	35
83460130	13	6.1	11.2	44.8	200	110	32	115	50	22	13	35
83460160	16	9.98	17	68	260	140	36	140	65	26	17	45
83460180	18	18.9	21.2	84.8	340	180	45	180	100	32	-	-
83460200	20	22.6	26.5	106	350	190	50	180	100	32	-	-
83460220	22	25.2	31.5	126	350	190	50	180	100	36	-	-
83460260	26	34.26	45	180	400	200	56	200	110	40	-	-
83460280	28	47.11	50	200	430	220	63	200	110	45	-	-
83460320	32	66.46	63	252	460	250	72	200	110	50	-	-

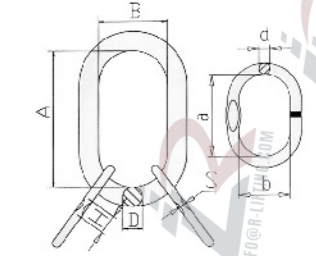

Cpd(A-343) (Wa-w) Master Link Welded (No Flat DIN5688 Master Link)

PART NO.	SIZE (mm)	WEIGHT /KG	WLL/T	B.L/T	A	B	D	S	L
83430706	7/6	0.34	1.6	6.4	110	60	13	7	25
83430807	8/7	0.54	2.12	8.48	110	60	16	7	25
83431008	10/8	0.823	3.15	12.6	135	75	18	7	35
83431310	13/10	1.5	5.3	21.2	160	90	22	11	35
83431613	16/13	2.32	8	32	180	100	26	13	45
83431816	18/16	3.95	11.2	44.8	200	110	32	17	45
83432018	20/18	6.34	14	56	260	140	36	-	-
83432220	22/20	8.96	17	68	300	160	40	-	-
83432622	26/22	12.8	21.2	84.8	340	180	45	-	-
83433226	32/26	16.55	31.5	126	350	190	50	-	-
83433632	36/32	23.28	45	180	400	200	56	-	-
83434036	40/36	32	56	224	430	220	63	-	-
83430720	72	45.76	63	252	460	250	72	-	-

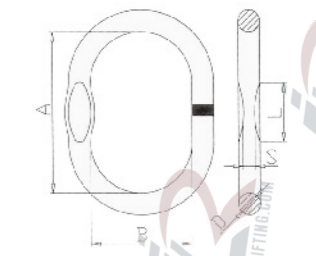

G80 FITTING

A-342 Forged Master Link

PART NO.	SIZE (inch)	WEIGHT /KG	WLL/T	B.L/T	A	B	D
8FML0102	1/2	0.36	3.2	16	127	63.5	13
8FML0508	5/8	0.7	4.1	20.5	152	76	16
8FML0304	3/4	0.93	5.6	28	140	70	19
8FML0708	7/8	1.5	6.8	34	160	90	22
8FML1000	1	2.1	11	55	178	89	25
8FML1104	1-1/4	4.24	16.4	82	222	111	32
8FML1102	1-1/2	7.17	24.6	123	267	135	38
8FML1304	1-3/4	11.55	38.5	192.5	305	152	45
8FML2000	2	17.2	46.5	232.5	355	178	51
8FML2104	2-1/4	24.5	64.9	324.5	406	203	57
8FML2102	2-1/2	30.9	72.6	363	406	203	63.5
8FML2304	2-3/4	39.5	98.4	492	406	241	70
8FML3000	3	50.34	103.4	517	457	228	76
8FML3104	3-1/4	65.68	119	595	508	254	82.5
8FML3102	3-1/2	90.24	126.5	632.5	310	305	89
8FML3304	3-3/4	89.27	152.4	762	508	254	95
8FML4000	4	103.43	169.2	846	508	254	101.6



A-345 Master Link Assembly (Forged Main Link)

PART NO.	SIZE (inch)	WEIGHT /KG	WLL /T	B.L/T	A	B	D	a	b	d	s
83450304	3/4	1.55	4.1	20.5	140	70	20	85	40	14	7.6
83451000	1	3.29	8.4	42	178	89	25	100	60	18	8.4
83451104	1-1/4	7.18	14.1	70.5	220	110	32	100	60	22	13.5
83451102	1-1/2	12.91	21.3	106.5	267	135	38	180	100	28	16.5
83451304	1-3/4	21.25	33.3	166.5	305	152	45	180	100	35	18.5
83452000	2	30.34	40.3	201.5	356	178	50	180	100	38	-

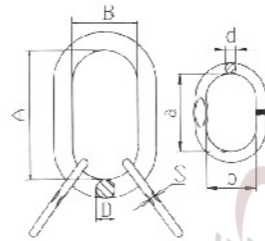

A-344 Master Link (Welded)

PART NO.	SIZE (inch)	WEIGHT /KG	CHAIN(4:1)		STEEL(5:1)		A	B	D	S
			WLL/T	B.L/T	WLL/T	B.L/T				
83440716	7/16	0.27	1.6	6.4	1.2	6	100	60	12	6
83440102	1/2	0.38	2.76	11.04	2.2	11	100	60	14	7.6
83441116	11/16	0.85	4	26	3.2	16	160	90	18	8.4
83340304	3/4	1.2	6.5	26	5.2	26	160	90	20	10.4
83340708	7/8	1.63	8.2	32.8	6.5	32.5	180	100	22	13.5
83341000	1	2.13	11.5	46	9.2	46	180	100	25	16.5
83341108	1-1/8	3.81	11.8	47.2	9.4	47	270	140	28	-
83341104	1-1/4	5.05	16	64	12.8	64	270	140	32	-

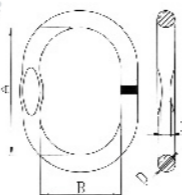

G80 FITTING

A-347 Master Link Assembly (Welded)

PART NO.	SIZE (inch)	WEIGHT /KG	CHAIN(4:1)		STEEL(5:1)		A	B	D	a	b	d	s
			WLL/T	B.L/T	WLL/T	B.L/T							
83470102	1/2	0.82	2.4	9.6	2	10	100	60	14	85	40	12	6
83471116	11/16	1.6	3.2	12.8	2.5	12.5	160	90	18	100	60	14	7.6
83470508	5/8	1.61	3.2	12.8	2.5	12.5	160	90	18	100	60	14	7.6
83470304	3/4	1.95	5	20	4	20	160	90	20	100	60	14	7.6
83470708	7/8	3.16	8	32	6.4	32	180	100	22	150	70	18	8.4
83471108	1-1/8	6.75	12	48	9.6	48	270	140	28	160	90	22	13.5
83471104	1-1/4	9.31	17.4	69.6	13.9	69.5	270	140	32	180	100	25	16.5
83471102	1-1/2	18.4	21	84	-	-	300	160	40	270	140	31	-
83471304	1-3/4	26.4	30	120	-	-	340	180	45	285	155	36	-
83472000	2	42.91	40	160	-	-	350	190	51	340	180	45	-

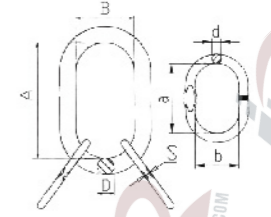

Master Link With Flat (Welded)

PART NO.	MODEL	WEIGHT /KG	WLL/T	B.L/T	A	B	D	S	H
8MLF13B5	13B5	0.3	2.6	10.4	95	51	13	7	50
8MLF13B6	13B6	0.35	2.4	9.6	115	60	13	7	50
8MLF16B6	16B6	0.6	3.8	15.2	120	70	16	9	70
8MLF16B7	16B7	0.86	2.8	11.2	190	100	16	9	70
8MLF20B6	20B6	1.1	6.4	25.6	150	80	20	11	50
8MLF20B7	20B7	1.25	5.8	23.2	170	90	20	11	70
8MLF22B6	22B6	1.53	7.6	30.4	170	90	22	12	70
8MLF22B7	22B7	1.83	6.4	25.6	210	110	22	12	70
8MLF25B6	25B6	2.21	10	40	190	100	25	13	80
8MLF28B6	28B6	3.06	12.7	50.8	210	110	28	15	80
8MLF28B7	28B7	3.81	10.5	42	270	140	28	15	70
8MLF32B6	32B6	5.05	15.2	60.8	270	140	32	17	70
8MLF38B6	38B6	7.3	25.1	100.4	270	140	38	20	55
8MLF38B7	38B7	10.78	17	68	420	220	38	20	55
8MLF45B6	45B6	12.2	34	136	320	170	45	24	60
8MLF45B7	45B7	17.06	24.5	98	470	250	45	24	60
8MLF50B6	50B6	17.65	40	160	380	200	50	-	-
8MLF60B6	60B6	28.85	58	232	430	220	60	-	-
8MLF70B6	70B6	45.48	84	336	500	250	70	-	-

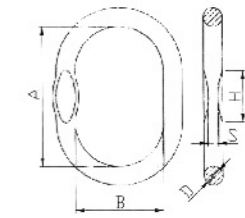

Master Link Assembly With Flat (Welded)

PART NO.	MODEL	WEIGHT /KG	WLL/T	B.L/T	A	B	D	a	b	d
8MLAMA16	16B	1.19	3.8	15.2	120	70	16	95	51	13
8MLAMA20	20B	2.41	5.8	23.2	170	90	20	120	70	16
8MLAMA22	22B	3.77	7.6	30.4	170	90	22	150	80	20
8MLAMA25	25B	4.45	10	40	190	100	25	150	80	20
8MLAMA28	28B	6.12	12.7	50.8	210	110	28	170	90	22
8MLAMA32	32B	9.47	15.2	60.8	270	140	32	190	100	25
8MLAMA38	38B	17.4	25	100	270	140	38	270	140	32
8MLAMA45	45B	26.76	34	136	320	170	45	270	140	38

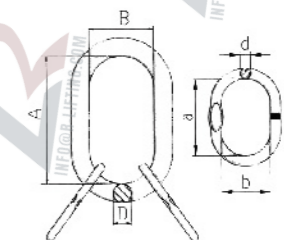



LIFTING EQUIPMENT



Steel Pulley

Part No.	Size (inch)	S.W.L (kgs)	Dia. of Rope (mm)	N.W. (kgs)
HSPM1102	1 1/2	300	5	0.11
HSPM2102	2 1/2	300	5	0.29
HSPA3102	3 1/2	450	12	0.60
HSPB3102	3 1/2	450	12	0.72
HSPC3102	3.5	450	12	0.60
HSPD3102	3.5	450	12	0.72



H418 Light Type Champion Snatch Block with Hook

Part No.	Size (inch)	S.W.L (ton)	Dia. of Rope (inch)	N.W. (kgs)
H4183000	3	2	3/8	2.3
H4184102	4 1/2	4	1/2	5.74
H4186000	6	8	3/4	11.5
H4188000	8	8	3/4	15.75
H418T100	10	8	3/4	21.9
H418T120	12	8	3/4	30
H418T140	14	8	3/4	36
H418T160	16	15	7/8	99
H418T180	18	15	1	112.5



H419 Light Type Champion Snatch Block with Shackle

Part No.	Size (inch)	S.W.L (ton)	Dia. of Rope (inch)	N.W. (kgs)
H4193000	3	2	3/8	2.24
H4194102	4 1/2	4	1/2	5.74
H4196000	6	8	3/4	12.5
H4198000	8	8	3/4	16.5
H419T100	10	8	3/4	22
H419T120	12	8	3/4	29.5
H419T140	14	8	3/4	35.6
H419T160	16	15	7/8	102
H419T180	18	15	1	118



H404 Light Type Champion Snatch Block tail Board

Part No.	Size (inch)	S.W.L (ton)	Dia. of Rope (inch)	N.W. (kgs)
H4043000	3	2	3/8	1.4
H4044102	4 1/2	4	1/2	3.44
H4046000	6	8	3/4	6.94
H4048000	8	8	3/4	11
H404T100	10	8	3/4	16
H404T120	12	8	3/4	25



LIFTING EQUIPMENT

HRBS Red Snatch Block with Shackle

Part No.	Size (inch)	S.W.L (ton)	Dia. of Rope (mm)	N.W. (kgs)
HRBS3500	3	1.5	4-6	1.5
HRBS4000	4	3	6-9	2.3
HRBS5000	5	4.5	8-12	4.14
HRBS6000	6	6	10-14	6.6
HRBS8000	8	8	14-18	13.5

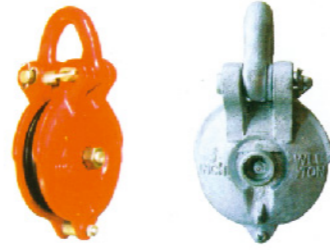

HRBE Red Snatch Block with Eye

Part No.	Size (inch)	S.W.L (ton)	Dia. of Rope (mm)	N.W. (kgs)
HRBE3000	3	1.5	4-6	1.65
HRBE4000	4	3	6-9	2.9
HRBE5000	5	4.5	8-12	5.4
HRBE6000	6	6	10-14	7.95
HRBE8000	8	8	14-18	18.05



Single Sheave Pulley

Part No.	Size (inch)	S.W.L (kgs)	Dia. of Rope (inch)	N.W. (kgs)
HSSP0102	1/2	50	5/32	0.015
HSSP0304	3/4	75	3/16	0.025
HSSP1000	1	100	1/4	0.05
HSSP1104	1 1/4	150	5/16	0.1
HSSP1308	1 3/8	200	5/16	0.13
HSSP1102	1 1/2	250	5/16	0.131
HSSP1304	1 3/4	275	3/8	0.21
HSSP2000	2	300	7/16	0.29
HSSP2102	2 1/2	350	1/2	0.5
HSSP3000	3	400	5/8	0.6
HSSP4000	4	450	3/4	1.7
HSSP5000	5	500	3/4	2.7



Double Sheave Pulley

Part No.	Size (inch)	S.W.L (kgs)	Dia. of Rope (inch)	N.W. (kgs)
HDSP0102	1/2	50	5/32	0.04
HDSP0304	3/4	75	3/16	0.06
HDSP1000	1	100	1/4	0.09
HDSP1104	1 1/4	150	5/16	0.15
HDSP1102	1 1/2	250	5/16	0.225
HDSP2000	2	300	7/16	0.4
HDSP2102	2 1/2	350	1/2	0.71
HDSP3000	3	400	5/8	1.16
HDSP4000	4	450	3/4	2.7
HDSP5000	5	500	3/4	4.6



LIFTING EQUIPMENT

Single Sheave Pulley Swivel

Part No.	Size (inch)	S.W.L (kgs)	Dia. of Rope (inch)	N.W. (kgs)
HSPS0102	1/2	50	5/32	0.02
HSPS0304	3/4	75	3/16	0.033
HSPS1000	1	100	1/4	0.0625
HSPS1104	1 1/4	150	5/16	0.085
HSPS1102	1 1/2	250	5/16	0.155
HSPS2000	2	300	7/16	0.39
HSPS2102	2 1/2	350	1/2	0.59
HSPS3000	3	400	5/8	0.80
HSPS4000	4	450	3/4	1.7
HSPS5000	5	500	3/4	2.7



Hay Fork Pulley

Part No.	Size (inch)	S.W.L (ton)	Dia. of Rope (inch)	N.W. (kgs)
HHFP4001	4	1	1 1/4	2.46
HHFP4002	4	1	1/2	2.36
HHFP6001	6	2	1 1/2	5.95
HHFP6001	6	2	5/8	6.25



Pulley Block double With Oval Eye A Type

Part No.	Size (inch)	S.W.L (ton)	Dia. of Rope (mm)	N.W. (kgs)
HPBA3000	3	0.5	8	1.65
HPBA4000	4	1	10	3.40
HPBA5000	5	1.5	13	5.25
HPBA6000	6	2	16	10.50
HPBA7000	7	3	19	14.30
HPBA8000	8	4	22	18.10
HPBAT100	10	5	25	28.80



Pulley Block double With Oval Eye B Type

Part No.	Size (inch)	S.W.L (ton)	Dia. of Rope (mm)	N.W. (kgs)
HPBB3000	3	0.5	8	1.65
HPBB4000	4	1	10	3.40
HPBB5000	5	1.5	13	5.25
HPBB6000	6	2	16	10.50
HPBB7000	7	3	19	14.30
HPBB8000	8	4	22	18.10
HPBBT100	10	5	25	28.80



Oval Eye Snatch Block

Part No.	Size (inch)	S.W.L (ton)	Dia. of Rope (mm)	N.W. (kgs)
HOES5000	5	3	18-20	6.70
HOES6000	6	5	20-22	11.60



LIFTING EQUIPMENT

Pulley Block single With Hook K Type

Part No.	Size (inch)	S.W.L (ton)	Dia. of Rope (mm)	N.W. (kgs)
HPBH3000	3	0.5	8	1.55
HPBH4000	4	1	10	2.60
HPBH5000	5	1.5	13	3.95
HPBH6000	6	2	16	6.6
HPBH7000	7	3	19	9.70
HPBH8000	8	4	22	13
HPBHT100	10	5	25	20
HPBHT120	12	6	28	27

Pulley Block single With Eye K Type

Part No.	Size (inch)	S.W.L (ton)	Dia. of Rope (mm)	N.W. (kgs)
HPBE3000	3	0.5	8	1.3
HPBE4000	4	1	10	2.5
HPBE5000	5	1.5	13	3.67
HPBE6000	6	2	16	6.75
HPBE7000	7	3	19	9.75
HPBE8000	8	4	22	12.20
HPBET100	10	5	25	18.30

H408 Light Type Champion Snatch Block double With Hook

Part No.	Size (inch)	S.W.L (ton)	Dia. of Rope (inch)	N.W. (kgs)
H4084102	4 1/2	4	1/2	9.5
H4086000	6	12	3/4	23.83
H4088000	8	12	3/4	32.17
H408T100	10	12	3/4	59.25
H408T120	12	12	3/4	50
H408T140	14	12	3/4	55.75
H408T160	16	15	7/8	183.25
H408T180	18	15	1	230

H409 Light Type Champion Snatch Block double With Shackle

Part No.	Size (inch)	S.W.L (ton)	Dia. of Rope (inch)	N.W. (kgs)
H4094102	4 1/2	4	1/2	10
H4096000	6	12	3/4	12
H4098000	8	12	3/4	29.67
H409T100	10	12	3/4	60
H409T120	12	12	3/4	50.5
H409T140	14	12	3/4	56.25
H409T160	16	15	7/8	183.25
H409T180	18	15	1	220

LIFTING EQUIPMENT

H420 Block (Champion Snatch Block with Hook)

Part No.	Size (in)	S.W.L (ton)	Diam Of Rope (in)	Q'ty/case (pcs)	N.W/G.W (kg)	Wd Size (cm)
H4206000	6	12	7/8	10	190/210	69 × 62 × 53
H4208000	8	15	7/8	10	280/300	74 × 69 × 62
H420T100	10	15	7/8	6	208/228	87 × 76 × 46

H421 Block (Champion Snatch Block with Shackle)

Part No.	Size (in)	S.W.L (ton)	Diam Of Rope (in)	Q'ty/case (pcs)	N.W/G.W (kg)	Wd Size (cm)
H4216000	6	12	7/8	10	210/230	69 × 62 × 53
H4218000	8	15	7/8	10	295/315	74 × 69 × 62
H421T100	10	15	7/8	6	225/250	87 × 76 × 46

H430 Block (Super Champion Snatch Block with Hook)

Part No.	Size (in)	S.W.L (ton)	Diam Of Rope (in)	Q'ty/case (pcs)	N.W/G.W (kg)	Wd Size (cm)
H4308000	8	20	1 1/8	6	300/330	105 × 79 × 41
H430T100	10	20	1 1/8	6	278/300	85 × 60 × 40
H430T120	12	20	1 1/8	4	215/240	85 × 62 × 45
H430T140	14	20	1 1/8	4	256/280	85 × 67 × 50
H430T180	18	25	1 1/8	4	523/550	120 × 61 × 66
H430T200	20	30	1 1/8	2	374/404	133 × 36 × 71

H431 Block (Super Champion Snatch Block with Shackle)

Part No.	Size (in)	S.W.L (ton)	Diam Of Rope (in)	Q'ty/case (pcs)	N.W/G.W (kg)	Wd Size (cm)
H4318000	8	20	1 1/8	6	315/340	105 × 80 × 41
H431T100	10	20	1 1/8	4	211/235	85 × 62 × 40
H431T120	12	20	1 1/8	4	240/265	85 × 64 × 45
H431T140	14	20	1 1/8	4	281/305	85 × 69 × 50
H431T180	18	25	1 1/8	4	523/550	120 × 61 × 66
H431T200	20	30	1 1/8	2	374/404	133 × 36 × 71

Heavy Duty Snatch Block (All Drop Forged)

Model	Working load (ton)	Hook latch H(mm)	Rope Dia. (mm)	Dimensions(mm)										N.W. (kg)
				B	B1	B2	H1	H2	H3	D1	D2	R		
KBO 05	0.5	20	φ 5	95	62	16	260	190	20	75	88	3	2	
KBO 10	1	23	φ 7	118	76	17	305	200	23	85	105	4	3.2	
KBO 20	2	27	φ 13	119	92	24	425	263	30	150	190	7	7.3	
KBO 3.2	3.2	31	φ 15	230	108	28	496	295	40	180	220	9	13.1	
KBO 6.4	6.4	24	φ 18	270	116	35	655	375	47	210	260	10	22.1	

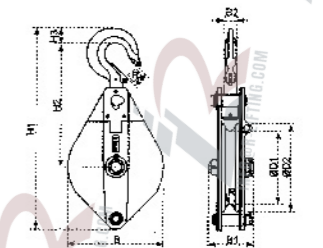

LIFTING EQUIPMENT

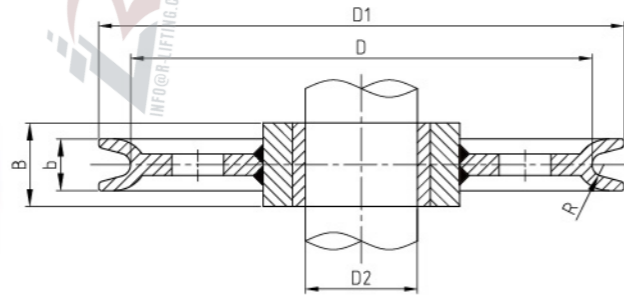

- Processed from high-quality low-content alloy steel plate by roll forging. It is of light weight and high strength, with wide application as well.
- The pulley material can be customized as required.
- Pulley with special dimensions can also be made according to the customer's drawing.
- Pulleys meeting API8C are accessible.

Part No.	Wire Rope Diameter (mm)	Size (mm)						Referential Bearing Model	Approx. Weight (Kg)
		D	D1	R	b	D2	B		
HBPL1014	10-14	280	325	7	37	55	63	211	14.5
						60	69	212	15
						65	75	213	16
						70	80	214	16
HBPL1419	> 14-19	355	415	10	50	80	90	216	26
						85	96	217	27.5
						90	102	218	28.5
						95	108	219	30
HBPL1924	> 19-23.5	450	521	12	60	95	108	219	40
						100	113	220	41.5
						110	124	222	44
						120	135	224	46
HBPL2430	> 23.5-30	560	650	15	73	130	146	226	73
						140	158	228	76
						150	170	230	79
						160	180	232	82
HBPL3037	> 30-37	710	822	19	92	160	188	42232	124
						170	202	42234	128
						180	212	42236	132
						190	225	42238	135
HBPL3743	> 37-43	800	926	22	104	160	188	42232	159
						170	202	42234	164.5
						180	212	42236	166
						190	225	42238	168
HBPL4350	> 43-50	900	1052	26	123	190	225	42238	278
						200	235	42240	275
						220	260	42244	305
						240	278	42248	286
HBPL5058	> 50-58	1120	1292	29	135	190	225	42238	385
						200	235	42240	384
						220	260	42244	417
						240	278	42248	397

*The approx. weight doesn't include the bearing weight.

LIFTING EQUIPMENT

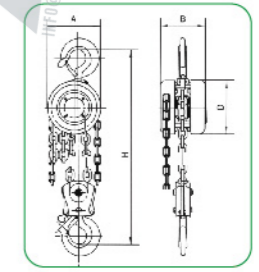

MODEL: SK



Model	SK-0.5	SK-1	SK-1.5	SK-2	SK-3	SK-5	SK-7.5	SK-10	SK-15	SK-20
Capacity(t)	0.5	1	1.5	2	3	5	7.5	10	15	20
Standard lift(m)	2.5	2.5	2.5	2.5	3	3	3	3	3	3
Running test load(t)	0.75	1.5	2.25	3	4.5	6.25	10	12.5	20	28
Headroom(drawn close up)Hmin(mm)	240	270	347	380	470	600	700	700	820	1000
Effort required to lift max.load(N)	221	304	343	314	343	381	392	392	392	392
No.of coluns of load chain	1	1	1	2	2	2	3	4	6	8
Load chain dia.(mm)	6	6	8	6	8	10	10	10	10	10
Dimensions(mm)	A	120	142	178	142	178	210	356	358	400
	B	108	122	139	122	139	162	162	196	189
	C	24	28	34	34	38	48	64	64	69
	D	120	142	178	142	178	210	210	210	210
Net Weight(kg)	8	10	16	14	24	36	58	68	112	155
Gross weight(kg)	10	13	20	17	28	45	70	83	127	193
Packing measurements (L x W x H)(cm)	28x21x17	30x24x18	34x29x20	33x28x19	38x38x20	45x39x24	62x50x28	55x51x29	68x60x34	70x46x75
Extra weight per meter of extra lift(kg)	1.7	1.7	2.3	2.5	3.7	5.3	7.3	9.7	14.1	19.4

MODEL: CK



Model	CK-0.5	CK-1	CK-1.5	CK-2D	CK-2	CK-3	CK-5	CK-10	CK-20
Capacity(t)	0.5	1	1.5	2	2	3	5	10	20
Standard lift(m)	2.5	2.5	2.5	3	2.5	3	3	3	3
Running test load(t)	0.75	1.5	2.25	3	3	4.5	6.25	12.5	25
Headroom(drawn close up)Hmin(mm)	258	274	347	444	396	486	616	700	1000
Effort required to lift max.load(N)	221	304	343	294	314	343	382	392	392
No.of coluns of load chain	1	1	1	1	2	2	2	4	8
Load chain dia.(mm)	6	6	8	8	6	8	10	10	10
Dimensions(mm)	A	125	147	183	215	147	183	215	360.5
	B	111	126	141	163	126	141	163	163
	C	24	28	34	38	34	38	48	64
	D	134	154	192	224	154	192	224	224
Net Weight(kg)	8	10	16	18	14	24	36	68	156
Gross weight(kg)	9	11	17	19	15	26	38	83	194
Packing measurements (L x W x H)(cm)	28x21x17	30x24x18	34x29x20	45x39x24	33x28x19	38x33x20	45x39x24	55x51x29	70x46x75
Extra weight per meter of extra lift(kg)	1.7	1.7	2.3	2.3	2.5	3.7	5.3	9.7	19.4

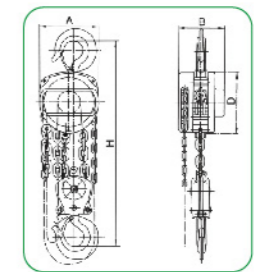

LIFTING EQUIPMENT



MODEL: VJ

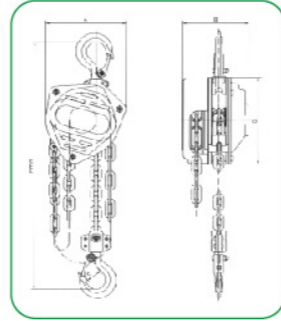

Model	VJ-0.5	VJ-1	VJ-1.5	VJ-2	VJ-3	VJ-5	VJ-10	VJ-20
Capacity(t)	0.5	1	1.5	2	3	5	10	20
Standard lift(m)	2.5	2.5	2.5	2.5	3	3	3	3
Running test load(t)	0.75	1.5	2.25	3	4.5	6.25	12.5	25
Headroom(drawn close up)Hmin(mm)	271	400	453	420	620	704	720	1000
Effort required to lift max.load(N)	221	304	343	314	343	382	392	392
No.of coluns of load chain	1	1	1	2	2	2	4	8
Load chain dia.(mm)	6	6	8	6	8	10	10	10
Dimensions(mm)	A	138	164	198	164	195	228	367
	B	114	124	142	124	142	167	167
	C	21.5	27	30	30	37	46	54
	D	145	182	219	182	219	252	252
Net Weight(kg)	9	11	17	15	24	39	72	160
Gross weight(kg)	11	14	21	18	28	48	87	190
Packing measurements (L x W x H)(cm)	28x21x17	30x24x18	34x29x20	33x28x19	38x33x20	45x39x24	55x51x29	70x46x75
Extra weight per meter of extra lift(kg)	1.7	1.7	2.3	2.5	3.7	5.3	9.7	19.4



MODEL: VC

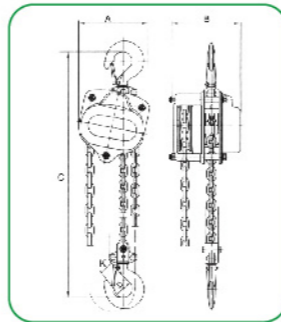

Model	VC-0.5	VC-1	VC-1.5	VC-2	VC-3	VC-5	VC-10	VC-20	VC-30	VC-50
Capacity(t)	0.5	1	1.5	2	3	5	10	20	30	50
Standard lift(m)	2.5	2.5	2.5	3	3	3	3	3	3	3
Running test load(t)	7.5	15	22.5	45	45	62.5	125	250	375	625
Effort required to lift max. load(N)	200(20.5)	320(32.5)	360(36.5)	365(370)	385(39)	465(44.3)	435(44.3)	435*2(44.3*2)	435*2(44.3*2)	435*2(44.3*2)
Load chain dia.(mm)	5*15	6.3*18	7.1*21	8*24	7.1*21	9*2.7	9*27	9.0*27	9.0*27	
Dimensions(mm)	A	131	140	161	161	161	183	207	215	350
	B	127	158	187	187	210	253	398	650	962
	C	270	317	399	414	465	636	798	890	1380
	D	35	40	45	50	58	64	85	110	110
	K	30	34	38	41	18	52	64	85	85
Net Weight(kg)	8.4	11	16.2	18.5	25.6	42.8	79.5	193	220	1095
Packing measurements (L x W x H)(cm)	22*15*19.5	23*18*19.5	28*21*24	28*21*24	32*21*26	40*21*21	64*21*21	64*38*64	72*50*68	110*100*130
Extra weight per meter of extra lift(kg)	1.7	1.7	2.3	2.3	3.7	5.6	9.7	19.4	26.4	48.4

LIFTING EQUIPMENT

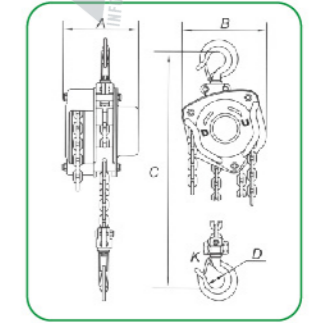

MODEL: TD



Model	TD-0.5	TD-1	TD-1.5	TD-2	TD-3	TD-5	TD-10	TD-20
Capacity(t)	0.5	1	1.5	2	3	5	10	20
Standard lift(m)	2.5	2.5	2.5	3	3	3	3	3
Running test load(t)	6.1	12.3	18.4	24.5	36.8	61.1	91.9	235.2
running test load(n)	200	320	360	365	385	435	414	414x2
strands of load chain	1	1	1	1	2	2	4	8
Load chain dia.(mm)	6	6	8	8	8	10	10	10
Dimensions(mm)	A	137.5	146.5	170	170	170	190	209
	B	137	162	183	194	220	288	384
	C	270	317	399	414	465	636	798
	D	35	35.5	45	42.5	50	64	85
	K	28	26	32.5	32	37	46	64
Net Weight(kg)	10	12	19	20	27	45.5	83	193
Packing measurements (L x W x H)(cm)	22x15x19.5	23x18x19.5	28x18x19.5	28x21x24	32x21x26	40x21x31	50x41x21	64x38x64
Extra weight per meter of extra lift(kg)	1.7	1.7	2.3	2.3	3.7	5.6	9.7	19.4



MODEL: VB

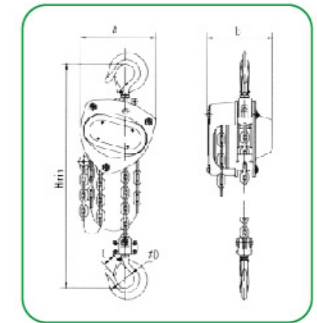

Model	VB-0.25	VB-0.5	VB-1	VB-1.5	VB-2	VB-3	VB-5	VB-10
Capacity(t)	0.25	0.5	1	1.5	2	3	5	10
Standard lift(m)	2.5	2.5	2.5	2.5	2.5	3	3	3
Effort required to lift max. load(N)	235	240	250	265	335	372	360	380
Load chain dia.(mm)	4x12	5x15	6x18	7x21	8x24	10x30	10x30	10x30
Headroom(Drawn close-up)mm Hmin	280	345	376	442	470	548	688	765
Dimensions(mm)	A	121	148	172	196	210	255	280
	B	114	132	151	173	175	205	189
	C	21	23	27	33	35	39	45
	D	31	35	40	45	50	55	65
Net Weight(kg)	6.5	9.3	12.2	16.5	19.5	32	41.1	75.7

LIFTING EQUIPMENT



MODEL: NC Chain Hoist

Model	Capacity (t)	Lifting Height(m)	Test Load (t)	Falls of Load Chain	Dimension of Load Chain(mm)	Force of Full Load(N)	Net Weight (kg)	Dimension (mm)				
								a	b	c	d	Hmin
NC005	0.5	3	0.75	1	5	250	9	140	123	22	34	350
NC010	1	3	1.5	1	6.3	330	11.8	245	143	24	34	390
NC015	1.5	3	2.25	1	7.1	340	14.5	165	143	30	46	430
NC020	2	3	3	1	8	340	19.4	190	175	30	46	480
NC030	3	3	4.5	2	7.1	350	21.7	190	143	32	52	520
NC050	5	3	7.5	2	9	390	36.4	240	175	25	63	690
NC100	10	3	15	4	9	410	69.3	370	190	60	80	1000
NC200	20	3	30	8	9	440	122	750	190	100	70	1400

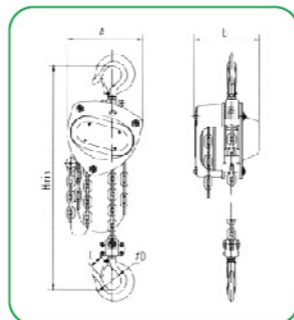

LIFTING EQUIPMENT

MODEL: MINI Chain Hoist

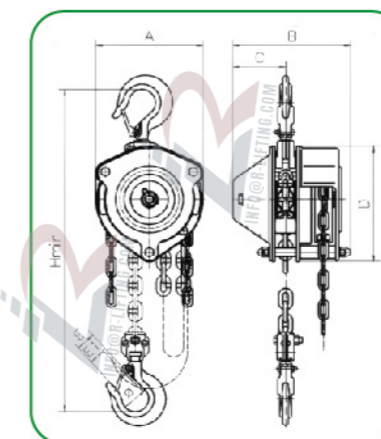

Model	MINI-0.25	MINI-0.5
Capacity(t)	0.25	0.5
Standard lift(m)	2	2.5
Running test load(t)	3.06	6.12
Headroom(drawn close up)-Hmin(mm)	215	255
Effort required to lift max.load(N)	125	180
No. of coluns of load chain	1	1
Load chain dia.(mm)	4mm*12	5mm*15
Dimensions(mm)	A	75
	B	116
	C	41
	D	157
	E	18
	E1	15.5
	Φ	25
Net Weight(kg)	3.5	4.5
Extra weight per meter of extra lift(kg)	0.35	0.55



MODEL: KC Chain Hoist

Model	Capacity (t)	Lifting Height(m)	Test Load (t)	Falls of Load Chain	Dimension of Load Chain(mm)	Force of Full Load(N)	Net Weight (kg)	Dimension (mm)				
								a	b	c	d	Hmin
KC010	1	3	1.25	1	6x18	315	11.3	160	129	30	42	330
KC020S	2	3	2.5	2	6x18	340	17.7	190	129	31	52	450
KC020	2	3	2.5	1	8x24	400	14.1	190	146	31	52	490
KC030	3	3	3.75	2	8x24	394	22.5	225	146	32	50	525
KC050	5	3	6.25	2	10x30	424	37.25	257	171	43	68	620

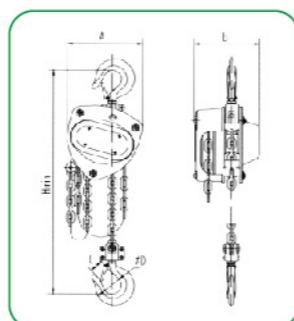

MODEL: MINI Lever Hoists

Model	MINI-0.25	MINI-0.5
Capacity(t)	0.25	0.5
Standard lift(m)	1	1.5
Running test load(t)	3.06	6.12
Headroom(drawn close up)-Hmin(mm)	215	255
Effort required to lift max.load(N)	125	180
No. of coluns of load chain	1	1
Load chain dia.(mm)	4mm*12	5mm*15
Dimensions(mm)	A	75
	B	116
	C	41
	D	157
	E	18
	E1	15.5
	Φ	25
Net Weight(kg)	2	3.5
Extra weight per meter of extra lift(kg)	0.35	0.55

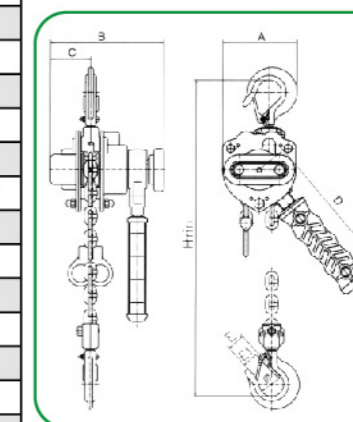

LIFTING EQUIPMENT

MODEL: VA ▶ Lever Hoist

Model	VA-0.75	VA-1.5	VA-3	VA-6	VA-9	
Capacity(t)	0.75	1.5	3	6	9	
Standard lift(m)	1.5	1.5	1.5	1.5	1.5	
Running test load(t)	11	22.5	37.5	75	112.5	
Effort required to lift max.load(N)	140	220	320	340	360	
No. of coluns of load chain	1	1	1	2	3	
Load chain dia.(mm)	6	8	10	10	10	
Dimensions(mm)	A	145	175	203	203	203
	B	86	100	118	118	118
	C	122	130	150	205	316
	D	37	45	50	64	85
	H	320	380	480	620	700
	L	285	370	410	410	410
	K	30	36	40	50	58
Net Weight(kg)	7.5	11.5	21	31.5	47	
Packing measurements (L x W x H)(cm)	35.5x14x16.5	46.5x15.5x19	51x19x21.5	53x22x21.5	82x32x21.5	
Extra weight per meter of extra lift(kg)	0.8	1.4	2.2	4.4	6.6	

MODEL: VL ▶ Lever Hoist

Model	VL-0.75	VL-1	VL-1.5	VL-3.0	VL-6.0	VL-9	
Capacity(t)	0.75	1	1.5	3	6	9	
Standard lift(m)	1.5	1.5	1.5	1.5	1.5	1.5	
Running test load(t)	9.2	12.3	18.4	36.8	73.5	110.3	
Effort required to lift max.load(kg)	148	197	216	336	345	357	
No. of coluns of load chain	1	1	1	1	2	3	
Load chain dia.(mm)	6.3	6.3	7.1	9	9	9	
Net Weight(kg)	6.6	6.6	11.65	21.1	23.7	54	
Dimensions(mm)	A	155	155	170	198	198	
	B	128	128	147	182	230	350
	C	310	310	350	470	590	740
	D	240	240	365	365	365	365
	E	28	32	36	47	49	65

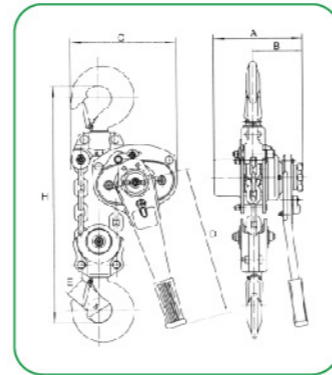

LIFTING EQUIPMENT

MODEL: KL ▶ Lever Hoist

Model	Rated Load ton	Test load kg	Standard lift m	Falls of load chain	Load chain diameter mm	Force of full load N	Net weight kg	Shipping weight kg	Dimension (mm)							
									a	b	c	d	e	g	s	t
KL080	0.8	1200	1.5	1	5.6	284	5.7	6	144	119	280	245	97	23.5	35.5	14
KL160	1.6	2400	1.5	1	7.1	333	8	8.3	159	126	335	265	100	32	42.5	19
KL320	3.2	4800	1.5	1	10	363	15	16	190	159	395	415	112	39	50	24.5
KL630	6.3	7900	1.5	2	10	372	26	27	190	217	540	415	112	50	60	34
KL900	9	11300	1.5	2	10	382	40	42	190	304	680	415	112	72.5	85	41.5

MODEL: NL ▶ Lever Hoist

Model	NL075	NL075	NL100	NL150	NL160	NL300	NL320	NL600	NL900	
Rated weight (kg)	750	800	1000	1500	1600	3000	3200	6000	9000	
Standard lifting height (m)	1.5	1.5	1.5	1.5	1.5	1.5	1.5	1.5	1.5	
Full load when the hand force	1	1	1	1	1	1	1	2	3	
Test load (N)	220	225	240	240	250	330	340	360	380	
Lifting chain specifications (kg)	1125	1200	1500	2250	2400	4500	4800	9000	13500	
Net weight (mm)	5.6X17	6X18	6X18	7.1X21	7.1X21	9X27	9X27	9X27	9X27	
Pack weight (kg)	5.3	5.6	5.6	8.6	8.6	15.2	15.2	23	43	
Package Size (kg)	5.6	5.9	5.9	8.9	8.9	15.6	15.6	23.5	44.5	
Weight for each additional 1m (kg/m)	31.5X16X12	31.5X16X12	31.5X16X12	35X18X13	35X18X13	48X20X13.5	48X20X13.5	48X21.5X17	53X28X25	
Size	a	115	115	115	137	137	169	169	238	300
	b	39	39	44	44	44	60	60	68	91
	c	239	239	239	259	259	374	374	374	374
	d	28	28	30	32	34	41	41	47	61
	e	146	146	146	162	162	187	187	187	187
	f	91	91	91	67	67	98	98	98	98
	Hmin	320	320	320	360	360	431	431	500	635

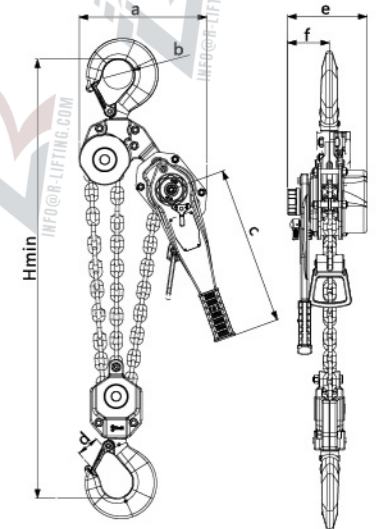

Due to continuous updating of our products, the data is subject to changes without notice.

LIFTING EQUIPMENT

MODEL: DL Aluminium alloy Lever hoist



Black, chic special bag, to the DL series of small hand pull the whole load. Can also be used on the belt.

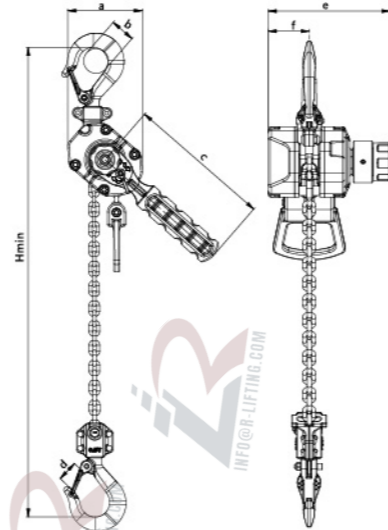

Model		DL025	DL050
Rated weight	(kg)	250	500
Standard lifting height	(m)	1.5	1.5
Full load when the hand force	(N)	170	200
Test load	(kg)	375	750
Lifting chain specifications	(mm)	3x9	4x12
Net weight	(kg)	1.6	2.7
Pack weight	(kg)	1.8	3.0
Weight for each additional 1m	(kg/m)	0.15	0.341
Size	a	74	90
	b	30	35
	c	142	175
	d	20	22
	e	105	117
	Hmin	223	282
	f	36	40

Due to continuous updating of our products, the data is subject to changes without notice.

Model		DL075	DL150	DL300	DL600	DL900
Rated weight	(kg)	750	1500	3000	6000	9000
Standard lifting height	(m)	1.5	1.5	1.5	1.5	1.5
Full load when the hand force	(N)	220	250	340	380	400
Test load	(kg)	1125	2250	4500	9000	13500
Lifting chain specifications	(mm)	5.6x17	7x21	9x27	9x27	9x27
Net weight	(kg)	5.1	7.6	14.7	20	39.5
Pack weight	(kg)	5.5	8.1	15.2	21.5	41.5
Weight for each additional 1m	(kg/m)	0.7	1.1	1.8	3.6	5.4
Size	a	115	140	170	237	300
	b	39	44	60	68	91
	c	233	233	350	350	350
	d	28	30	41	47	61
	e	140	158	185	185	185
	Hmin	329	355	445	500	635
	f	55	70	88	88	90

Due to continuous updating of our products, the data is subject to changes without notice.

LIFTING EQUIPMENT

MODEL: HSH-DC Lever Hoist



Model		HSH-DC250	HSH-DC500
Rated weight	(kg)	250	500
Standard lifting height	(m)	1.5	1.5
Full load when the hand force	(N)	260	260
Test load	(kg)	375	750
Lifting chain specifications	(mm)	4x12	4x12
Net weight	(kg)	2.2	3.2
Pack weight	(kg)	2.4	3.4
Package Size	(cm)	21x12.5x11.5	23.5x13.5x12
Weight for each additional 1m	(kg/m)	0.346	0.346
Size	a	86	95
	b	155	178
	c	170	170
	d	30	35
	e	79	87
	Hmin	245	285
	f	97	117
	G	22	22
	H	77	80

Due to continuous updating of our products, the data is subject to changes without notice.

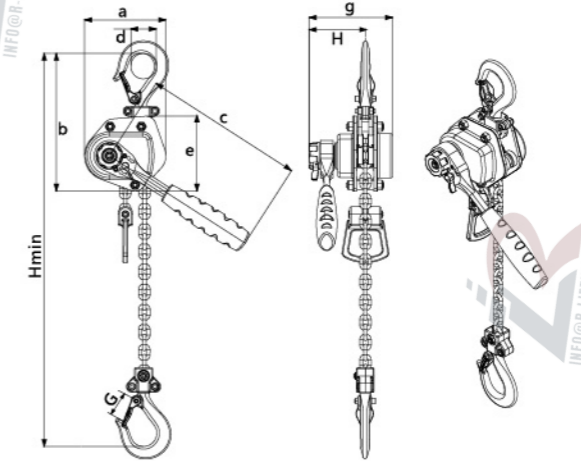

Model		HSH-DC750	HSH-DC1500	HSH-DC2500	HSH-DC3000	HSH-DC5000	HSH-DC6000
Rated weight	(kg)	750	1500	2500	3000	5000	6000
Standard lifting height	(m)	1.5	1.5	1.5	1.5	1.5	1.5
Full load when the hand force	(N)	220	240	330	350	350	380
Test load	(kg)	1125	2250	3750	4500	7500	9000
Lifting chain specifications	(mm)	5x15	7x21	9x27	9x27	9x27	9x27
Net weight	(kg)	4.7	7.6	14	14	22	22
Pack weight	(kg)	5	8	14.5	14.5	22.5	22.5
Package Size	(cm)	30x14x14	33x18x15.7	44x20x19	44x20x19	49x23.5x21.5	49.5x23.5x21.5
Weight for each additional 1m	(kg/m)	0.541	1.1	1.8	1.8	1.8	1.8
Size	a	121	139	173	173	173	173
	b	204	235	286	286	340	340
	c	240	240	335	385	335	385
	d	39	44	60	60	68	68
	e	112	133	162	162	162	162
	Hmin	335	365	448	448	600	600
	f	124	159	178	178	178	178
	G	28	30	41	41	47	47
	H	84	90	97	97	97	97

Due to continuous updating of our products, the data is subject to changes without notice.

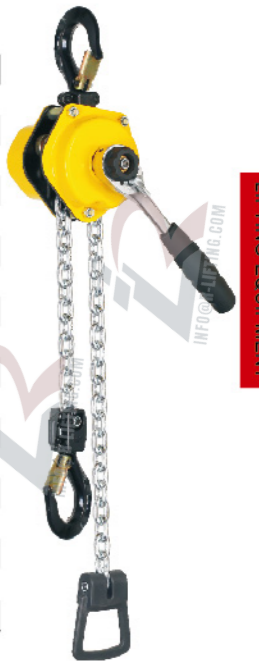

LIFTING EQUIPMENT

MODEL: HTG

Model		HTG-005	HTG-010	HTG-020	HTG-030	HTG-050	HTG-100
Rated weight	kg	500kg	1000kg	2000kg	3000kg	5000kg	10000kg
Standard lifting height	(m)	3	3	3	3	3	3
Number of hoisting chains		1	1	1	1	2	3
Full load when the pull force	(N)	240	305	360	370	370	400
Test load	(kg)	750	1500	3000	4500	7500	15000
Lifting chain diameter x Number of rows	(mm)	5x15	6x18	8x24	10x30	10x30	10x30
Hand chain diameter x Number of rows	(mm)	5x25	5x25	5x25	5x25	5x25	5x25
Lifting chain lifting height for each additional weight of 1m	(kg/m)	0.541	0.77	1.36	2.2	4.4	6.6
Pack weight	(kg)	14.8	23.5	43.7	58	84	140
Minimum clearance Hmin	(mm)	250	259	376	447	595	806
I-beam width	(mm)	50-203	74-203	85-203	100-203	114-203	124-203
Minimum corner radius	(m)	0.85	1	1.1	1.3	1.4	3
Size	a	210	240	280	340	420	452
	b	312	382	481	588	753	988
	c	208	312	329	351	368	387
	d	190	203	203	203	205	203
	e	24	26	35	37	40	41
	F	22	30	34	41	47	61
	G	35	44	49	60	68	91

Due to continuous updating of our products, the data is subject to changes without notice.

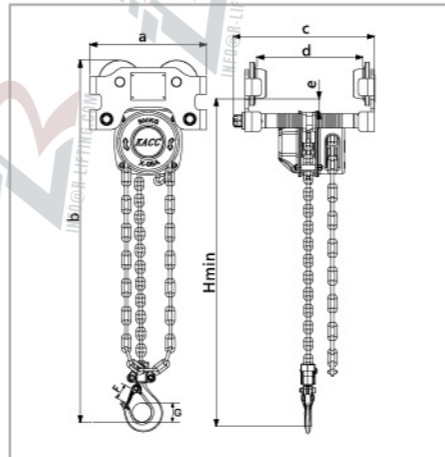
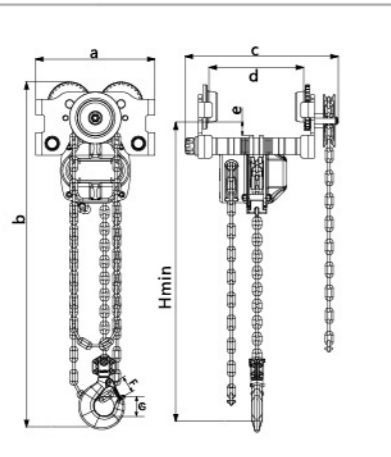

MODEL: HTP

Model		HTP-005	HTP-010	HTP-020	HTP-030	HTP-050	HTP-100
Rated weight	kg	500kg	1000kg	2000kg	3000kg	5000kg	10000kg
Standard lifting height	(m)	3	3	3	3	3	3
Number of hoisting chains		1	1	1	1	2	3
Full load when the pull force	(N)	240	305	360	370	370	400
Test load	(kg)	750	1500	3000	4500	7500	15000
Lifting chain diameter x Number of rows	(mm)	5x15	6x18	8x24	10x30	10x30	10x30
Hand chain diameter x Number of rows	(mm)	5x25	5x25	5x25	5x25	5x25	5x25
Pack weight	(kg)	13.5	22	42	56	82	140
Lifting chain lifting height for each additional weight of 1m	(kg/m)	0.541	0.77	1.36	2.2	4.4	6.6
Minimum clearance Hmin	(mm)	250	259	376	447	595	806
I-beam width	(mm)	50-203	74-203	85-203	100-203	114-203	124-203
Minimum corner radius	(m)	0.85	1	1.1	1.3	1.4	3
Size	a	210	240	280	340	420	452
	b	312	382	481	588	753	988
	c	255	259	284	302	318	338
	d	190	203	203	203	205	203
	e	24	26	35	37	40	41
	F	22	30	34	41	47	61
	G	35	44	49	60	68	91

Due to continuous updating of our products, the data is subject to changes without notice.



MODEL: NHSS

Alum. Body Type

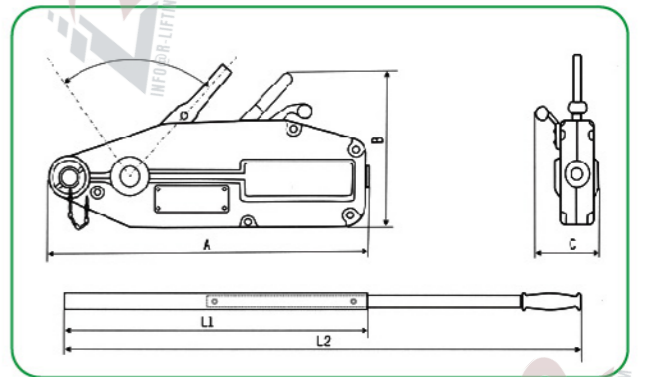
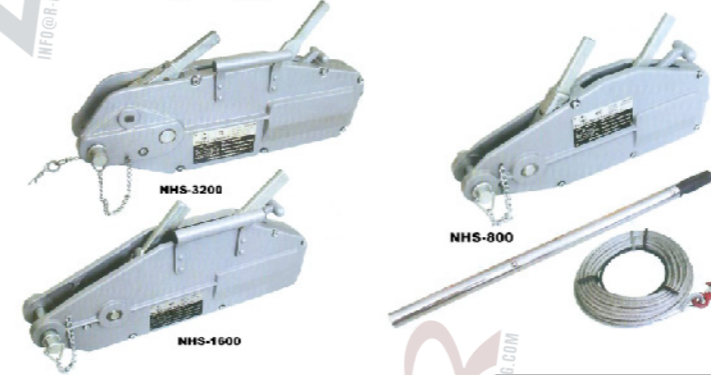

Model	NHSS-800	NHSS-1600	NHSS-3200	NHSS-5400
Capacity(kg)	800	1600	3200	5400
rared for wan handpower(N)	343	441	441	745
rated for ward travel(mm)	≥52	≥55	≥28	≥30
rope die meter(mm)	8.3	11	16	20
wire rope safety factor load capacity(times)	5	5	5	5
safety factor & static load capacity	5	5	5	5
running test load(kg)	1200	2400	4000	8000
Dimensions(mm)	A	426	545	660
	B	235	280	325
	C	64	97	116
	L1(cm)	88	80	80
L2(cm)	136	120	120	
Net Weight(kg)	6	11	22	58

MANUAL INSTRUCTION:

- Push ahead the handle of pincers C, Cis in the position when you hear crack sound. The mouth of the pincers will be opened for the wire rope.
- Fix the machine, adjust the length of wire rope, press the handle C backward till the mouth of pincers bites the wire rope.

- Insert the bar in handle A, and swing it front and backward. The wire rope will move ahead accordingly.
 - Insert the bar in handle B, and swing it front and backward. The wire rope will move backward and come out of the mouth of pincers.
 - Make sure of the condition that wire rope is under no pulling force and repeat the first step.
- Open the mouth of pincers, and take out the wire rope, and then press handle C backward.
- Finally, put the machine back into the box for the next time.

MODEL: NHST

Steel Type



Model	NHST08	NHST16	NHST32
Capacity(kg)	800kg	1600kg	3200kg
Rated load level of traction	1250kg	2500	5000kg
Rated load biggest lever	≤343N, ≤35Kgf	≤441N, ≤45Kgf	≤441N, ≤45Kgf
Handle reciprocating steel rope biggest stroke at a time	≥46mm	≥42mm	≥16mm
Weight	7kg	14kg	25kg
Size	420×102×250mm	620×126×315mm	630×150×360mm
Rope die meter(mm)	8.3mm	11mm	16mm

MODEL: KKBB

Electric Chain Hoists

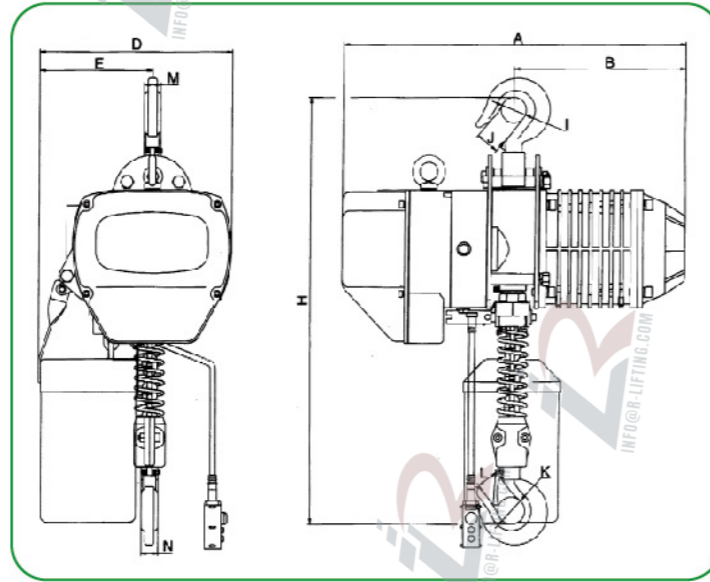

Model	Capacity (t)	Lifting Speed (m/min)	Lifting motor					Operating motor					I-beam (mm)
			Power (kw)	Rotation speed (r/min)	Phases	Voltage (v)	Frequency (Hz/s)	Power (kw)	Rotation speed (r/min)	Phases	Voltage (v)	Frequency (Hz/s)	
KKBB0.5-01	0.3	7.8	1.1	1440	3	220-440	50/60	\	\	\	\	\	\
KKBB0.5-01	0.5	7.8	1.1	1440	3	220-440	50/60	\	\	\	\	\	\
KKBB01-01	1	6.8	1.5	1440	3	220-440	50/60	\	\	\	\	\	\
KKBB01-02	1	3.9	1.1	1440	3	220-440	50/60	\	\	\	\	\	\
KKBB1.5-01	1.5	8.8	3.0	1440	3	220-440	50/60	\	\	\	\	\	\
KKBB02-01	2	6.6	3.0	1440	3	220-440	50/60	\	\	\	\	\	\
KKBB02-02	2	3.4	1.5	1440	3	220-440	50/60	\	\	\	\	\	\
KKBB2.5-01	2.5	5.6	3.0	1440	3	220-440	50/60	\	\	\	\	\	\
KKBB03-01	3	5.6	3.0	1440	3	220-440	50/60	\	\	\	\	\	\
KKBB03-02	3	4.4	3.0	1440	3	220-440	50/60	\	\	\	\	\	\
KKBB05-02	5	2.8	3.0	1440	3	220-440	50/60	\	\	\	\	\	\

Model	Capacity (t)	Dimensions (mm)											
		H	A	B	D	E	I	J	K	L	M	N	Chain
KKBB0.5-01	0.3	580	455	230	240	155	φ 31	29	φ 31	29	20	20	φ 6.3
KKBB0.5-01	0.5	580	455	230	240	155	φ 31	29	φ 31	29	20	20	φ 6.3
KKBB01-01	1	650	520	260	300	176	φ 42	32	φ 42	32	24	24	φ 7.1
KKBB01-02	1	680	455	230	240	155	φ 42	32	φ 42	32	24	24	φ 6.3
KKBB1.5-01	1.5	800	615	295	430	265	φ 49	40	φ 49	40	30	30	φ 10.0
KKBB02-01	2	800	615	295	430	265	φ 49	40	φ 49	40	30	30	φ 10.0
KKBB02-02	2	835	520	260	300	236	φ 49	40	φ 49	40	30	30	φ 7.1
KKBB2.5-01	2.5	845	615	295	430	265	φ 59	48	φ 59	48	35	35	φ 11.2
KKBB03-01	3	845	615	295	430	265	φ 59	48	φ 59	48	35	35	φ 11.2
KKBB03-02	3	950	615	295	430	320	φ 59	48	φ 59	48	35	35	φ 10.0
KKBB05-02	5	1030	615	295	430	325	φ 60	48	φ 60	48	43	43	φ 11.2

MODEL: KKBB

Electric Chain Hoists

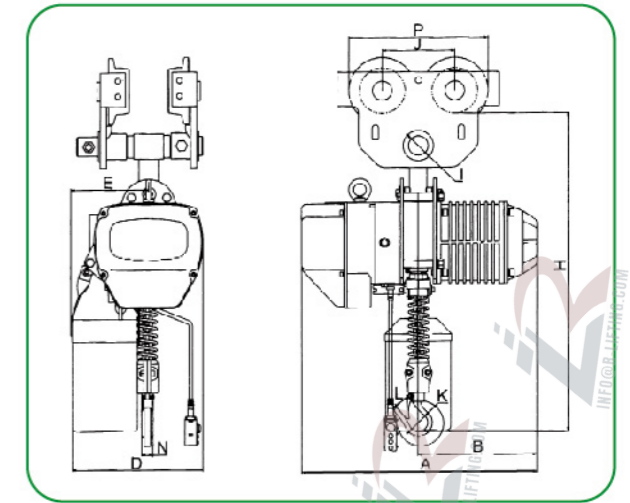

WITH MANUAL TROLLEY

Model	Capacity (t)	Lifting Speed (m/min)	Lifting motor					Operating motor					I-beam (mm)
			Power (kw)	Rotation speed (r/min)	Phases	Voltage (v)	Frequency (Hz/s)	Power (kw)	Rotation speed (r/min)	Phases	Voltage (v)	Frequency (Hz/s)	
KKBB0.5-01	0.3	7.8	1.1	1440	3	220-440	50/60	\	\	\	\	\	68-130
KKBB0.5-01	0.5	7.8	1.1	1440	3	220-440	50/60	\	\	\	\	\	68-130
KKBB01-01	1	6.8	1.5	1440	3	220-440	50/60	\	\	\	\	\	68-130
KKBB01-02	1	3.9	1.1	1440	3	220-440	50/60	\	\	\	\	\	68-130
KKBB1.5-01	1.5	8.8	3.0	1440	3	220-440	50/60	\	\	\	\	\	82-153
KKBB02-01	2	6.6	3.0	1440	3	220-440	50/60	\	\	\	\	\	82-153
KKBB02-02	2	3.4	1.5	1440	3	220-440	50/60	\	\	\	\	\	82-153
KKBB2.5-01	2.5	5.6	3.0	1440	3	220-440	50/60	\	\	\	\	\	82-153
KKBB03-01	3	5.6	3.0	1440	3	220-440	50/60	\	\	\	\	\	82-153
KKBB03-02	3	4.4	3.0	1440	3	220-440	50/60	\	\	\	\	\	82-153
KKBB05-02	5	2.8	3.0	1440	3	220-440	50/60	\	\	\	\	\	100-178

Model	Capacity (t)	Dimensions (mm)											
		H	A	B	D	E	K	L	N	I	J	P	Chain
KKBB0.5-01	0.3	580	455	230	240	155	φ 31	29	20	φ 27	91	163	φ 6.3
KKBB0.5-01	0.5	580	455	230	240	155	φ 31	29	20	φ 27	91	163	φ 6.3
KKBB01-01	1	650	520	260	300	176	φ 42	32	24	φ 31	115	221	φ 7.1
KKBB01-02	1	680	455	230	240	155	φ 42	32	24	φ 31	115	221	φ 6.3
KKBB1.5-01	1.5	800	615	295	430	265	φ 49	40	30	φ 36	138	265	φ 10.0
KKBB02-01	2	800	615	295	430	265	φ 49	40	30	φ 36	138	265	φ 10.0
KKBB02-02	2	835	520	260	300	236	φ 49	40	30	φ 36	138	265	φ 7.1
KKBB2.5-01	2.5	845	615	295	430	265	φ 59	48	35	φ 43	157	277	φ 11.2
KKBB03-01	3	845	615	295	430	265	φ 59	48	35	φ 43	157	277	φ 11.2
KKBB03-02	3	950	615	295	430	320	φ 59	48	35	φ 43	157	277	φ 10.0
KKBB05-02	5	1030	615	295	430	325	φ 60	48	43	φ 45	178	332	φ 11.2

LIFTING EQUIPMENT

MODEL: KKBB

Electric Chain Hoists

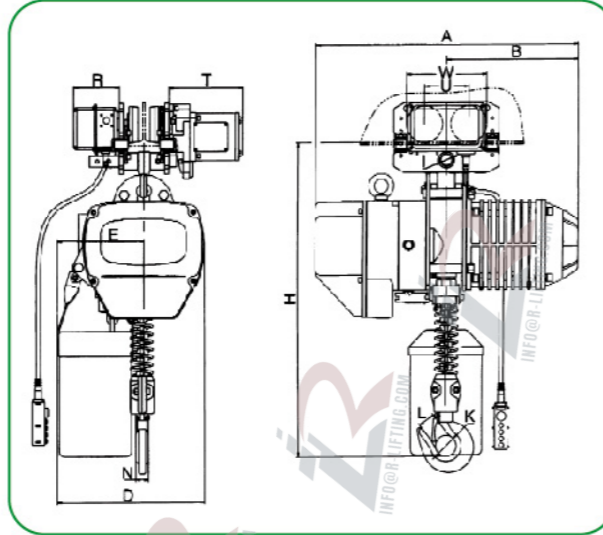

WITH ELECTRIC TROLLEY

Model	Capacity (t)	Lifting Speed (m/min)	Lifting motor					Operating motor					I-beam (mm)	
			Power (kw)	Rotation speed (r/min)	Phases	Voltage (v)	Frequency (Hz/s)	Power (kw)	Rotation speed (r/min)	Operating speed (m/min)	Phases	Voltage (v)		Frequency (Hz/s)
KKBB0.5-01	0.3	7.8	1.1	1440	3	220-440	50/60	0.12	1440	24	3	220-440	50/60	68-130
KKBB0.5-01	0.5	7.8	1.1	1440	3	220-440	50/60	0.12	1440	24	3	220-440	50/60	68-130
KKBB01-01	1	6.8	1.5	1440	3	220-440	50/60	0.4	1440	11/21	3	220-440	50/60	68-130
KKBB01-02	1	3.9	1.1	1440	3	220-440	50/60	0.4	1440	11/21	3	220-440	50/60	68-130
KKBB1.5-01	1.5	8.8	3.0	1440	3	220-440	50/60	0.4	1440	11/21	3	220-440	50/60	82-153
KKBB02-01	2	6.6	3.0	1440	3	220-440	50/60	0.4	1440	11/21	3	220-440	50/60	82-153
KKBB02-02	2	3.4	1.5	1440	3	220-440	50/60	0.4	1440	11/21	3	220-440	50/60	82-153
KKBB2.5-01	2.5	5.6	3.0	1440	3	220-440	50/60	0.75	1440	11/21	3	220-440	50/60	82-153
KKBB03-01	3	5.6	3.0	1440	3	220-440	50/60	0.75	1440	11/21	3	220-440	50/60	82-153
KKBB03-02	3	4.4	3.0	1440	3	220-440	50/60	0.75	1440	11/21	3	220-440	50/60	82-153
KKBB05-02	5	2.8	3.0	1440	3	220-440	50/60	0.75	1440	11/21	3	220-440	50/60	100-178

Model	Capacity (t)	Dimensions (mm)												
		H	A	B	D	E	K	L	N	I	J	P	Chain	
KKBB0.5-01	0.3	580	455	230	240	155	φ31	29	20	φ27	91	163	φ6.3	
KKBB0.5-01	0.5	580	455	230	240	155	φ31	29	20	φ27	91	163	φ6.3	
KKBB01-01	1	650	520	260	300	176	φ42	32	24	φ31	115	221	φ7.1	
KKBB01-02	1	680	455	230	240	155	φ42	32	24	φ31	115	221	φ6.3	
KKBB1.5-01	1.5	800	615	295	430	265	φ49	40	30	φ36	138	265	φ10.0	
KKBB02-01	2	800	615	295	430	265	φ49	40	30	φ36	138	265	φ10.0	
KKBB02-02	2	835	520	260	300	236	φ49	40	30	φ36	138	265	φ7.1	
KKBB2.5-01	2.5	845	615	295	430	265	φ59	48	35	φ43	157	277	φ11.2	
KKBB03-01	3	845	615	295	430	265	φ59	48	35	φ43	157	277	φ11.2	
KKBB03-02	3	950	615	295	430	320	φ59	48	35	φ43	157	277	φ10.0	
KKBB05-02	5	1030	615	295	430	325	φ60	48	43	φ45	178	332	φ11.2	

LIFTING EQUIPMENT

MODEL: KKBB

Electric Chain Hoists

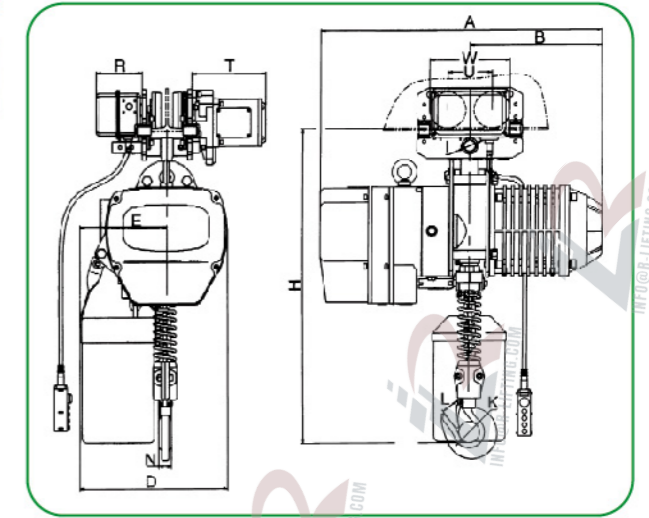

HOIST PARAMETERS OF DUAL SPEEDS

Model	Capacity (t)	Lifting Speed (m/min)	Lifting motor					I-beam (mm)
			Power (kw)	Rotation speed (r/min)	Phases	Voltage (v)	Frequency (Hz/s)	
KKBB01-01D	1	2.3/6.9	0.6/1.8	930/2830	3	220-440	50/60	68-130
KKBB1.5-01D	1.5	2.9/8.8	1.0/3.0	930/2830	3	220-440	50/60	82-153
KKBB02-01D	2	2.2/6.6	1.0/3.0	930/2830	3	220-440	50/60	82-153
KKBB02-02D	2	1.1/3.3	0.6/1.8	930/2830	3	220-440	50/60	82-153
KKBB2.5-01D	2.5	1.8/5.6	1.0/3.0	930/2830	3	220-440	50/60	82-153
KKBB03-01D	3	1.8/5.6	1.0/3.0	930/2830	3	220-440	50/60	82-153
KKBB03-02D	3	1.5/4.5	1.0/3.0	930/2830	3	220-440	50/60	82-153
KKBB03-03D	3	0.8/2.3	0.6/1.8	930/2830	3	220-440	50/60	82-153
KKBB05-02D	5	0.9/2.8	1.0/3.0	930/2830	3	220-440	50/60	100-178

Model	Capacity (t)	Dimensions (mm)														
		H	A	B	D	E	I	K	L	N	W	U	R	T	Chain	
KKBB01-01D	1	650	595	280	300	236	φ31	φ42	32	24	207	113	142	231	φ7.1	
KKBB1.5-01D	1.5	770	675	315	430	265	φ36	φ49	40	30	237	127	142	231	φ10.0	
KKBB02-01D	2	770	675	315	430	265	φ36	φ49	40	30	237	127	142	231	φ10.0	
KKBB02-02D	2	815	595	280	300	236	φ36	φ49	40	30	237	127	142	231	φ7.1	
KKBB2.5-01D	2.5	830	675	315	430	265	φ43	φ59	48	35	265	140	142	231	φ11.2	
KKBB03-01D	3	830	675	315	430	265	φ43	φ59	48	35	265	140	142	231	φ11.2	
KKBB03-02D	3	930	675	315	430	320	φ43	φ59	48	35	265	140	142	231	φ10.0	
KKBB03-03D	3	1015	595	280	430	176	φ43	φ59	48	35	265	140	142	231	φ7.1	
KKBB05-02D	5	1015	675	315	430	325	φ54	φ60	48	43	296	156	142	231	φ11.2	

LIFTING EQUIPMENT

MODEL: CQ Mini Electric Hoists

Features:

European Standard Attestation CE,GS,EMC & RoHS
 Adopt urgent stop switch and reinforced breaking switch with position limit.
 Protection class up to IP54.
 With thermal prevention device



Model	CQ-PA200A		CQ-PA250A		CQ-PA300A		CQ-PA400A		CQ-PA500A		CQ-PA600A		CQ-PA700A		CQ-PA800A		CQ-PA1000A		CQ-PA1200A	
Method of use	Single hook	Double hook	Single hook	Double hook	Single hook	Double hook	Single hook	Double hook	Single hook	Double hook	Single hook	Double hook	Single hook	Double hook	Single hook	Double hook	Single hook	Double hook	Single hook	Double hook
Rated volt(V)	AC 220/230/240 50/60Hz																			
Input power(W)	480		510		600		950		1020		1200		1250		1300		1600		1800	
Rated capacity(kg)	100	200	125	250	150	300	200	400	250	500	300	600	350	700	400	800	500	1000	600	1200
Lifting speed(M/min)	10	5	10	5	10	5	10	5	10	5	10	5	8	4	8	4	8	4	8	4
Lifting height(m)	12	6	12	6	12	6	12	6	12	6	12	6	12	6	12	6	12	6	12	6
Qty./CTN(pcs)	2										1									
Packing size(mm)	470*370*160						520*420*170						560*250*350							
G.w/N.w(kg)	24/22		25/23		35/33		39/37		33/32											

MODEL: CQR Mini Electric Hoist With Moving Vehicle

Features:

Adopt urgent stop switch and reinforced breaking switch with position limit.
 Protection class up to IP54.
 With thermal prevention device



Model	CQR-200C		CQR-250C		CQR-300C		CQR-400C		CQR-500C		CQR-600C		CQR-700C		CQR-800C		CQR-1000C		CQR-1200C	
Method of use	Single hook	Double hook	Single hook	Double hook	Single hook	Double hook	Single hook	Double hook	Single hook	Double hook	Single hook	Double hook	Single hook	Double hook	Single hook	Double hook	Single hook	Double hook	Single hook	Double hook
Rated volt(V)	AC 100/110/120/ 220/230/240 50/60Hz										AC 220/230/240 50/60Hz									
Input power(W)	100	200	125	250	150	300	200	400	250	500	300	600	350	700	400	800	500	1000	600	1200
Rated capacity(kg)	12/6										1000									
Lifting speed(M/min)	500										1000									
Lifting height(m)	13																			
Qty./CTN(pcs)	1																			
Packing size(mm)	490*410*470						540*480*480						620*510*530							
G.w/N.w(kg)	31/29		35/33		35/33		39/37		56/54											

LIFTING EQUIPMENT

Suspending Electric winch



Model	ATX-180A	ATX-250A
Rated load	180KG	250KG
Speed	12m/min	
Voltage	AC 100-240V/50/60HZ	
Power source	1300W	
Lift height	25M	15M
Diameter	Φ4*25mm	Φ5*15mm
Dimension	477*265*280mm	
Weight	18.5KG/17KG	

KDA-GT250A Suspension Hoist

SDY300 Portable Crane

GF800A Electric Windlass



Model	GF-800A
Rated Volt	230V 50Hz
Input Power(W)	1600
Capacity(KG)	800
Lifting Height(M)	20
Lifting Speed(m/min)	9
Wire Diameter(mm)	6
Breaking Strength(N/M2)	>1870
Insulation Grade	B
Protection Grade	IP54
Duty	M1

Model	SDY300
Rated Volt	230V 50Hz
Input Power(W)	1200
Capacity(KG)	300
Lifting Height(M)	25
Lifting Speed(m/min)	9
Wire Diameter(mm)	5.1
Breaking Strength(N/M2)	>1870
Insulation Grade	B
Protection Grade	IP54
Duty	M1
Net Weight(KG)	22

Model	GT250A
Rated Volt	230V 50Hz
Current(A)	5.7
Input Power(W)	1300
Capacity(KG)	250
Lifting Height(M)	60
Lifting Speed(m/min)	15
Wire Diameter(mm)	5.1
Breaking Strength(N/M2)	>1870
Insulation Grade	B
Protection Grade	IP54
Working Rate	S3 40%~10min
Duty	M1
Advised Beam Diameter(mm)	40-50
Net Weight(KG)	31

LIFTING EQUIPMENT

MODEL: AP

Plain Trolley

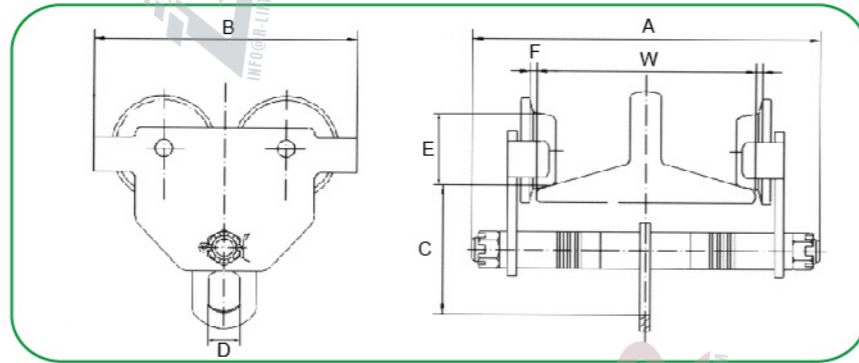

Model	Capacity (ton)	Fits Beam (mm)				Dimensions(mm)						Minimum Revolving Radius(mm)	N.W. (kg)
		W		H		A	B	C	D	E	F		
AP005	0.5	75	125	100	150	206	174	120	45	55	27	900	7.8
AP010	1	75	125	125	250	206	231	120	45	80	27	1300	14
AP020	2	100	150	150	400	241	271	155	60	100	33	1500	22
AP030	3	100	150	180	400	261	311	185	70	113	47	2000	35
AP050	5	125	175	250	450	294	351	220	80	125	53	2600	47
AP100	10	150	175	250	450	294	721	165	∞	125	53	∞	87

MODEL: AG

Geared Trolley

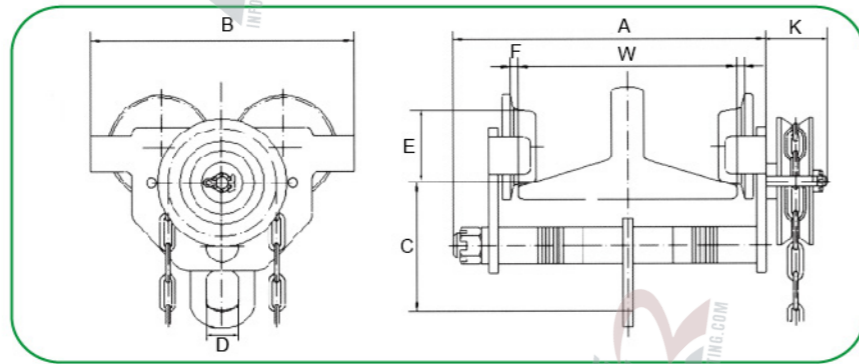

Model	Capacity (ton)	Fits Beam (mm)				Dimensions(mm)						Minimum Revolving Radius	N.W. (kg)	
		W		H		A	B	C	D	E	F			K
AG010	1	75	125	125	250	206	231	120	45	80	27	117	1300	15
AG020	2	100	150	150	400	241	271	155	60	100	33	119	1500	23
AG030	3	100	150	180	400	261	311	185	70	113	47	134	2000	36
AG050	5	125	175	250	450	294	351	220	80	125	53	134	2600	49
AG100	10	150	175	250	450	294	721	165	∞	125	53	134	∞	89

LIFTING EQUIPMENT

MODEL: GCT-A

Plain Trolley

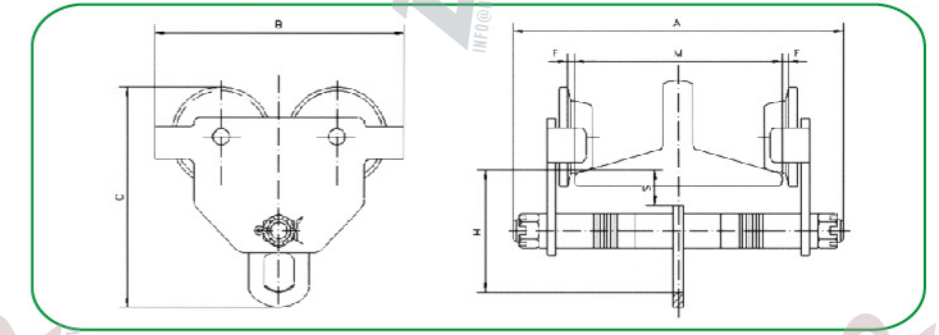

Model	GCT-A0.5	GCT-A1	GCT-A1.5	GCT-A2	GCT-A3	GCT-A5	GCT-A10	GCT-A20	
Capacity(t)	0.5	1	1.5	2	3	5	10	20	
Running test load(kN)	7.35	14.71	22.06	29.42	44.13	61.29	122.58	245.7	
Min radius of curve(m)	0.8	0.9	1	1	1.2	1.3	2	3.5	
Dimensions(mm)	A	186-236	263-303	245-310	260-317	284-333	322-355	525	600
	B1	174	206	219	233	276	302		
	B2	194	236	250	268	322	362	424	555
	C	176	208	225	247	295	342	396	498
	H	95	111	121	134	157	185	190	233
	F	1.5-3						2-3.5	
I-beam commended(mm)	50-152	64-203	74-203	88-203	100-203	114-203	124-305	136-305	
Net Weight(kg)	5	9	11.5	14	24	37			

MODEL: GCL-A

Geared Trolley

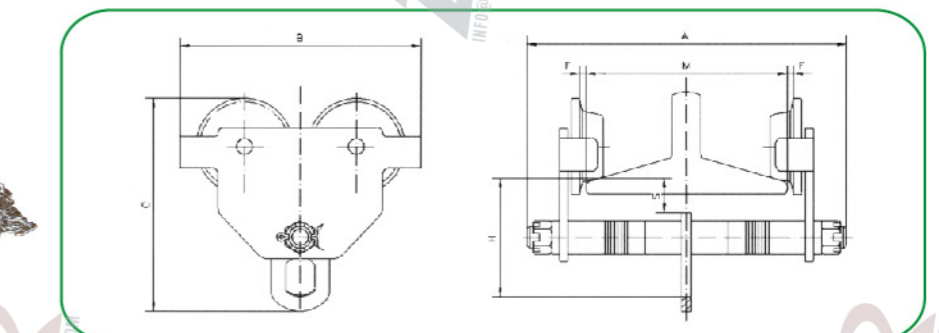

Model	GCL-A0.5	GCL-A1	GCL-A1.5	GCL-A2	GCL-A3	GCL-A5	GCL-A10	GCL-A20	
Capacity(t)	0.5	1	1.5	2	3	5	10	20	
Running test load(kN)	7.35	14.71	22.06	29.42	44.13	61.29	122.58	245.7	
Min radius of curve(m)	0.8	0.9	1	1	1.2	1.3	2	3.5	
Dimensions(mm)	A	186-236	263-303	245-310	260-317	284-333	322-355	525	600
	B1	174	206	219	233	276	302		
	B2	194	236	250	268	322	362	424	555
	C	176	208	225	247	295	342	396	498
	H	95	111	121	134	157	185	190	233
	F	1.5-3						2-3.5	
I-beam commended(mm)	50-152	64-203	74-203	88-203	100-203	114-203	124-305	136-305	
Net Weight(kg)	5	9	11.5	14	24	37			

LIFTING EQUIPMENT

MODEL: GCT-B Plain Trolley

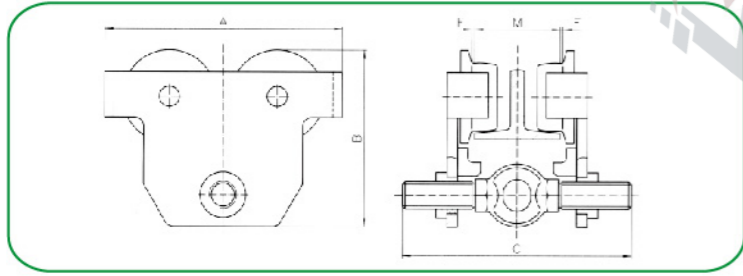

Model	GCT-B0.5T	GCT-B1T	GCT-B2T	GCT-B3T	GCT-B5T	
Capacity(kg)	500	1000	2000	3000	5000	
Running test load(kN)	7.35	14.7	29.42	44.13	61.29	
Min radius of curve(m)	0.9	1	1.2	1.3	1.4	
Dimensions(mm)	A	225	252	300	360	
	B	176.5	188	226	290	
	a	292	300	310	324	
	b	377	385	395	409	
Asius table beam width(mm)	M	≈ 3				
	a	64-220	64-220	88-220	102-220	114-220
Net weight(kg)	b	160-305	160-305	160-305	160-305	160-305
	a	8.3	10.9	18.2	31.4	42.6
Volume(cm)	b	8.7	11.4	19	32.5	44
	a	28.5X8.5X33.5	28.5X8.5X33.5	28.5X8.5X25	40X34X33	45X36X36
	b	28.5X8.5X42	28.5X8.5X42	42X15X25	40X42X33	45X36X44

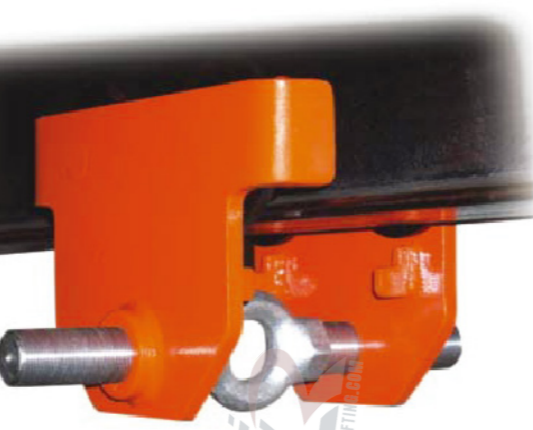

GCT-B type plain trolley have 5 specifications from 1/2 to 5t. the plain trolley is moved by pushing the load lifted by the trolley, running on the bottom flange of monorail. with the screw hanger to adjust the width of i-beam. they are widely used in factories, mines, wharves, docks, warehouses and engine rooms for installation of equipment and conveyance of goods, they are especially suitable for maintenance and repairing of equipment in places where no power supply is available.

GCL-B type geared trolley have 5 specifications from 1/2 to 5t. The geared trolley is hand-operated by pulling the hand-chain. Running on the bottom flange of monorail. with the screw hanger to adjust the width of i-beam. They are widely used in factories, mines, wharves, docks, warehouses and engine rooms for installation of equipment and conveyance of goods, they are especially suitable for maintenance and repairing of equipment in places where no power supply is available.

MODEL: GCL-B Geared Trolley

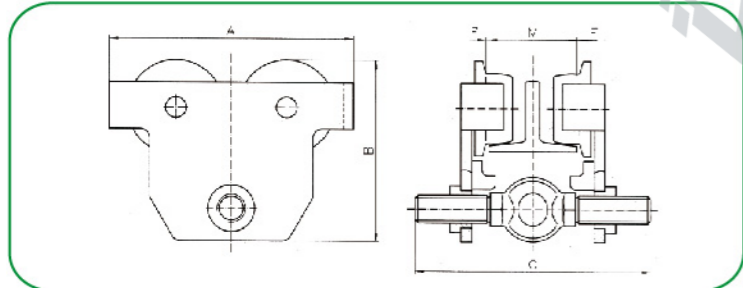

Model	GCL-B0.5T	GCL-B1T	GCL-B2T	GCL-B3T	GCL-B5T	
Capacity(kg)	500	1000	2000	3000	5000	
Running test load(kN)	7.35	14.7	29.42	44.13	61.29	
Min radius of curve(m)	0.9	1	1.2	1.3	1.4	
Dimensions(mm)	A	225	252	300	360	
	B	173	188	226	290	
	a	292	300	310	324	
	b	377	385	395	409	
Asius table beam width(mm)	M	≈ 3				
	a	64-220	64-220	88-220	102-220	114-220
Net weight(kg)	b	160-305	160-305	160-305	160-305	160-305
	a	13.3	15.9	23.2	37.7	48.9
Volume(cm)	b	13.7	16.4	24	38.8	50.3
	a	33X29X24.5	33X29X24.5	38.5X33X29	39X38X35	46.5X39X37
	b	42X29X24.5	42X29X24.5	46X33X29	46X38X35	53X39X37

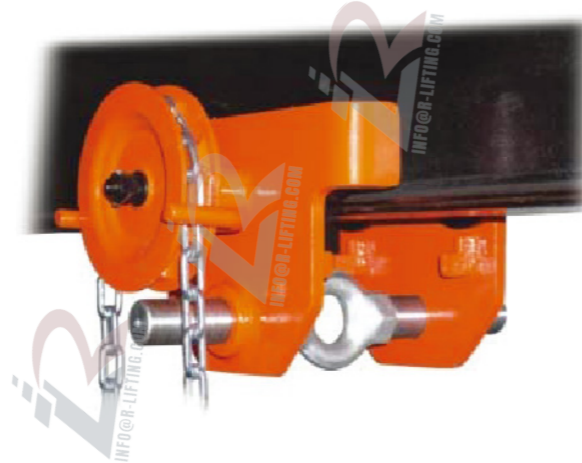

LIFTING EQUIPMENT

MODEL: TBC I-beam Clamp

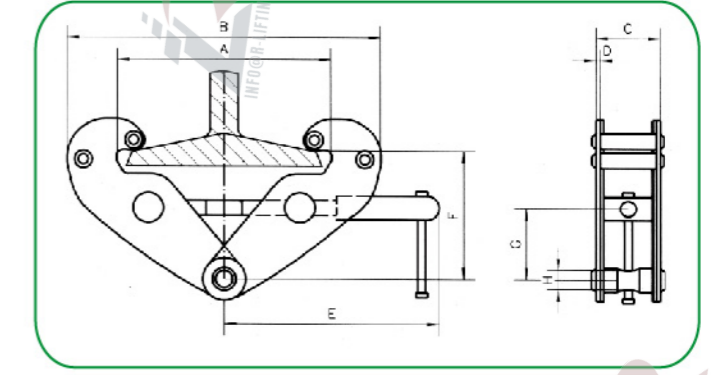

Model	1T	2T	3T	5T	10T
Capacity(kg)	1000	2000	3000	5000	10000
Running test load(kN)	14.71	29.42	44.13	61.29	122.58
Adjustable Beam Width(MM)	75 - 230	75 - 230	80 - 320	90 - 320	90 - 320
Dimensions(mm)	Amax	278	278	356	356
	Bmax	380	380	500	500
	Bmin	183	183	220	220
	C	64	76	100	112
	D	4	6	8	10
	E	217	217	277	277
	Fmax	150	150	220	220
	Fmin	90	90	145	145
G	26	26	50	47	
H	19	21	23	29	
Net weight(kg)	3.5	4.5	9.5	11	

MODEL: TBE I-beam Clamp With Eye

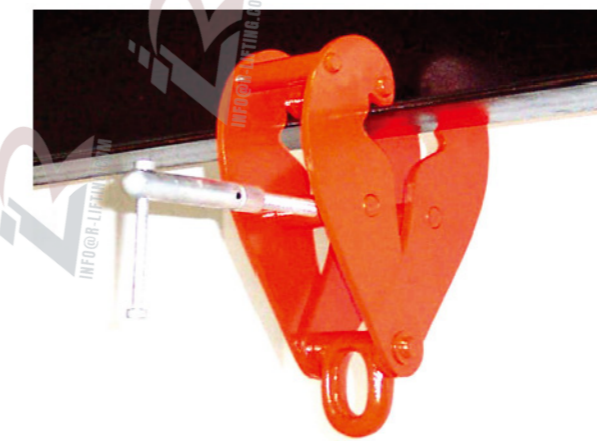

For the Transfer of Steel Beams and Attachment of Tackle Eye

- Available in capacities of 2 thru 10 metric tons.
- Welded alloy steel body for strength and smaller size. Forged alloy components, where required.
- Individually proof tested to 2 times the working load limit with certification.
- Each product is individually serialized, with the serial number and proof load test date stamped on body. Serial number is included on the test certificate with maintenance and warranty logbook.
- Maintenance replacement parts are available.
- Maintenance by a ISO9001 facility.
- All sizes are RFID EQUIPPED.

OPTIONAL EXTRA

- Can be supplied with shackle.
- Special design with flattened, reinforced jaws

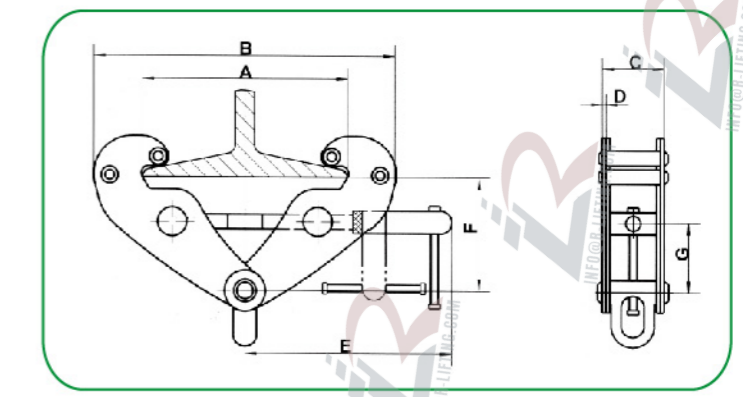

Model	1T	2T	3T	5T	10T
Capacity(kg)	1000	2000	3000	5000	10000
Running test load(kN)	14.71	29.42	44.13	61.29	122.58
Adjustable Beam Width(MM)	75 - 230	75 - 230	80 - 320	90 - 320	90 - 320
Dimensions(mm)	Amax	278	278	356	356
	Bmax	380	380	500	500
	Bmin	183	183	220	220
	C	64	76	100	112
	D	4	6	8	10
	E	217	217	277	277
	Fmax	150	150	220	220
	Fmin	90	90	145	145
G	26	26	50	47	
Net weight(kg)	3.5	4.5	9.5	11	

LIFTING EQUIPMENT

MODEL: E Vertical Lifting Clamp

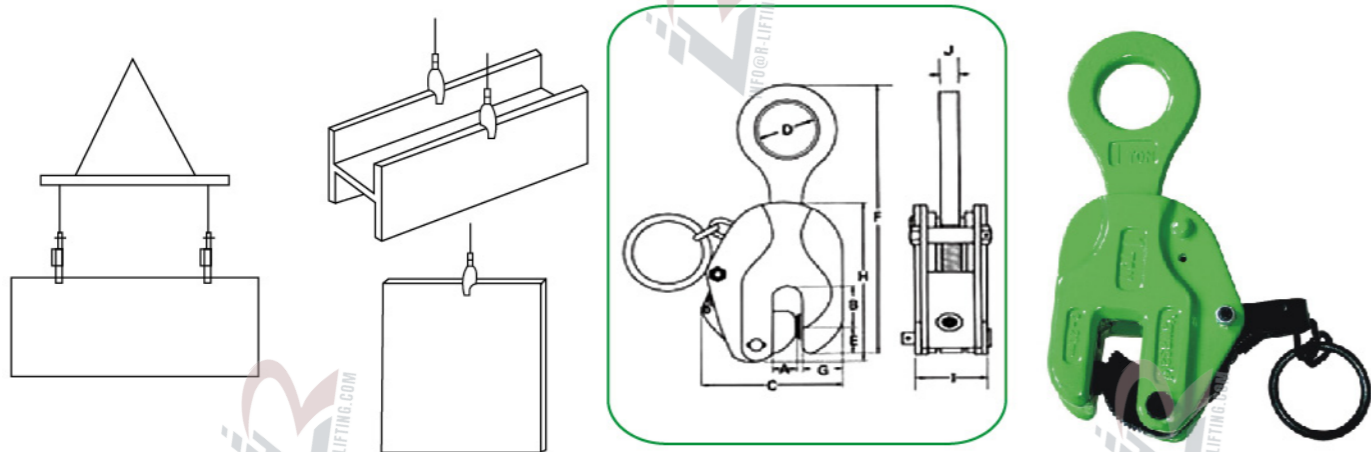

Model	Capacity (ton)	Running test load (kN)	Opening size (MM)	Dimensions (mm)										Net weight (KG)
				A	B	C	D	E	F	G	H	I	J	
E-0001	1000	19.6	0-22	24	36	125	50	24	220-260	30	156	52	14	3.6
E-0002	2000	39.2	0-30	35	45	155	60	30	250-295	38	190	60	18	6
E-0003	3000	58.8	0-35	40	50	175	60	35	296-360	40	226	68	20	9.2
E-0005	5000	98	0-50	50	58	218	65	42	350-420	60	270	76	22	16.5

LIFTING EQUIPMENT

MODEL: QC-A Vertical Lifting Clamp

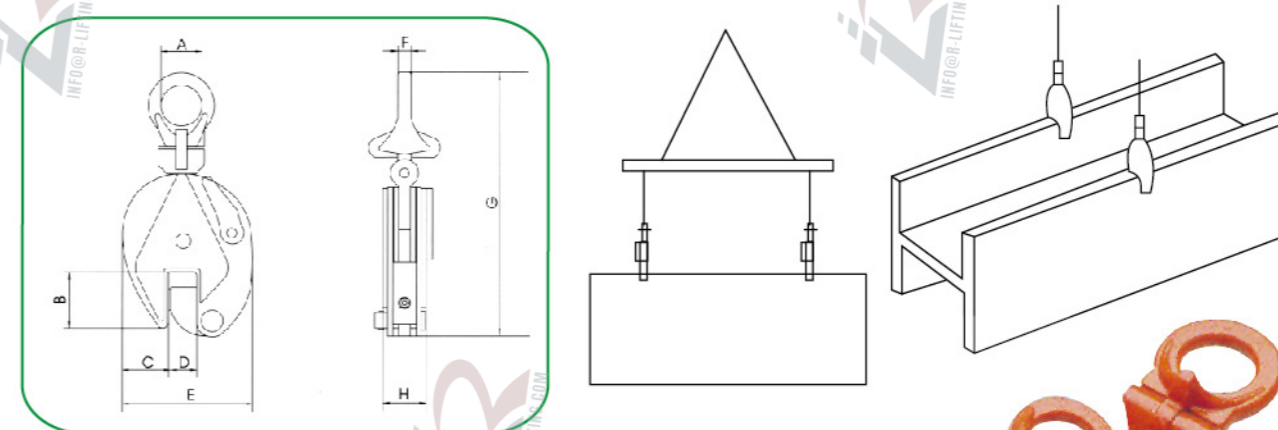

Model	0.5 T	1T	2T	3T	5T	
Capacity(kg)	500	1000	2000	3000	5000	
Running test load(kN)	7.35	14.7	29.4	44.1	73.5	
Max.Jaw Opening(mm)	15	20	25	30	50	
Dimensions(mm)	A	30	48	68	74	80
	B	43	63	76	85	90
	C	34.5	51	59	56	65
	D	0-17	0-22	0-27	0-32	0-52
	E	103	138	164	193	240
	F	10	12	16	20	22
	G	212	294	370	418	450
	H	36	50	52	78	88
Net weight(kg)	2	4.8	6.8	15	23	
Volume(cm)	23 x 5 x 11.5	37 x 7 x 16	38 x 8 x 9	45 x 11 x 22	46 x 11 x 22	

MODEL: HLC Horizontal Lifting Clamp

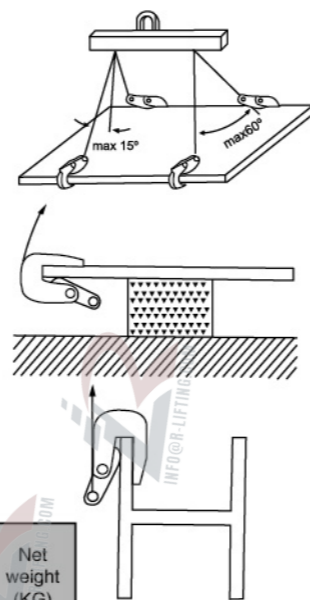
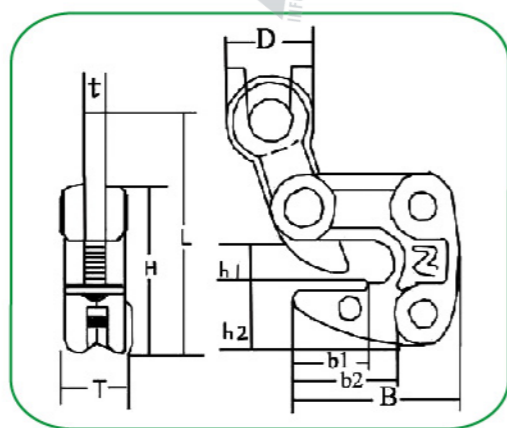

Model	Capacity (ton)	Opening size (MM)	Dimensions (mm)										Net weight (KG)	
			L	t	T	H	h1	h2	B	b1	b2	D		d
HLC-1	1000	1-13	173	14	32	104	23.5	39.5	105	66	44	72	46	1.6
HLC-2	2000	3-22	233	18	42	130	36	50	137	87	58	96	61	3.9
HLC-3	3000	12-35	261	23	52	177	42	67.5	173.5	107	68	80	35	9

MODEL: QP-A Horizontal Lifting Clamp

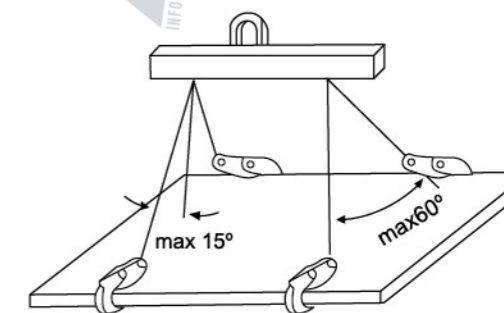
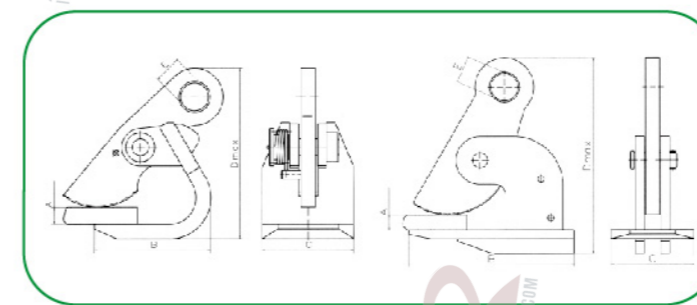

Model	QP-A750	QP-A1500	QP-A2500	
Capacity(kg)	Single	750	1500	2500
	Double	1500	3000	5000
Running test load(kN)	Single	11.04	22.07	36.79
	Double	22.07	44.13	73.58
Jaw opening (MM)		0-50	0-50	0-60
Dimensions (mm)	Amin	50	50	60
	B	127	220	260
	C	100	110	130
	Dmax	218	270	315
	E	φ 30	φ 36	φ 40
	F			
Net weight (kg)	Single	4.3	7.7	14.1
	Double	8.6	15.4	28.2
Volume (cm)		17 x 12 x 24	26 x 13 x 20	30 x 15 x 23



LIFTING EQUIPMENT

MODEL: QP-B

Horizontal Lifting Clamp

Model	QP-B750	QP-B1500	QP-B2500	
Capacity(kg)	Single	750	1500	2500
	Double	1500	3000	5000
Running test load(KN)	Single	11.04	22.07	36.79
	Double	22.07	44.13	73.58
Jaw opening(MM)		0-25	0-25	0-40
	Amin	25	30	50
Dimensions(mm)	B	125	157	231
	C	50	65	90
	Dmax	175	204	310
	E	φ25	φ30	φ40
Net weight(KG)	Single	2.4	3.9	13.4
	Double	4.8	7.8	26.8
Volume(cm)		17 x 8 x 19	21 x 9 x 22	30 x 12 x 31

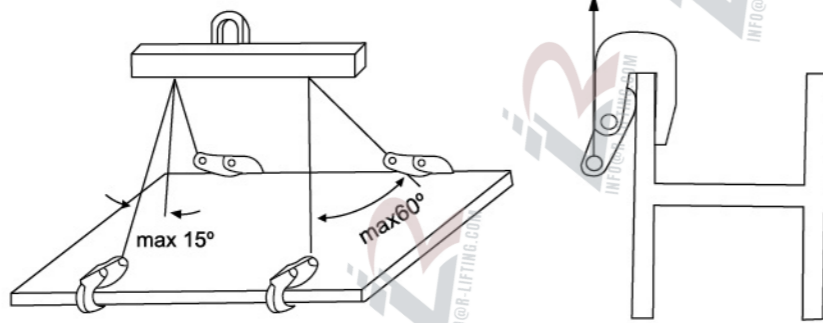
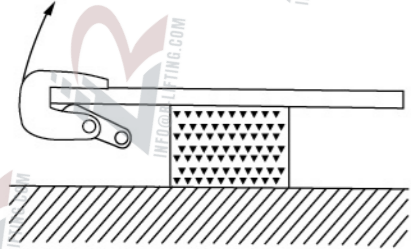
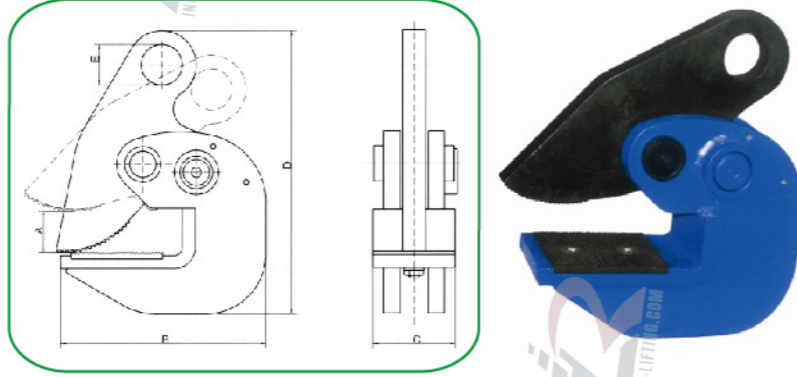

MODEL: VK

Pallet Clamp



Model	VK-2	VK-3	
Capacity(lbs)	2000	5000	
Test load(lbs)	3000	7500	
Max. open width:E(mm)	127	135	
Net weight(kg)	5	7.8	
Dimensions(mm)	A	242	275
	B	75	95
	C	435	485
	D	302	336
	F	205	236
φ	42	50	
Pack size(cm)	32*22*10	35*24*12	

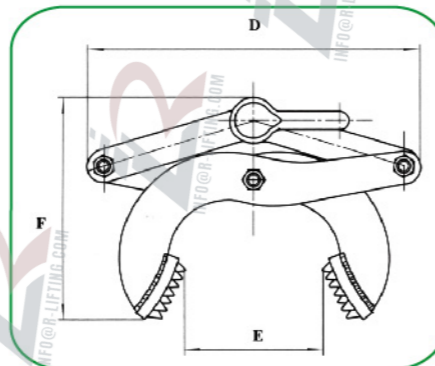
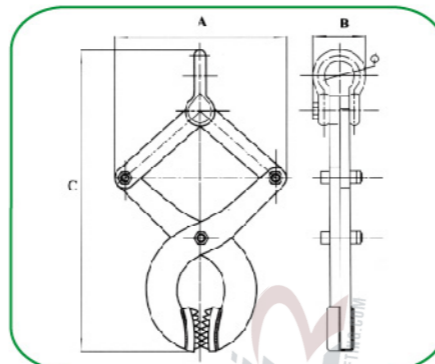

LIFTING EQUIPMENT

MODEL: GPW-C

Hand Winch With Brake

Friction disc brake

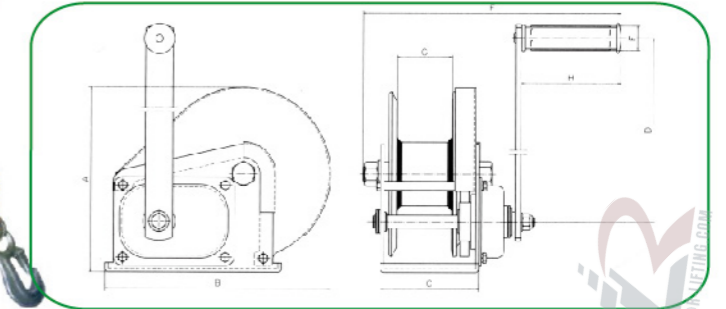

Model (LBS)	Test Load (KN)	Gear Ratio	Dimensions(mm)								Net weight (KG)
			A	B	C	D	E	F	G	H	
1200	8	4:02:01	156	184	88	210	27	272	51	109	3.7
1800	12.13	5:01	203	256	107	319	27	283	60	109	7.7
2600	17.64	10:01	216	293	127	319	27	305	63	109	10.1

MODEL: GPW-B

Hand Winch

Gear brake

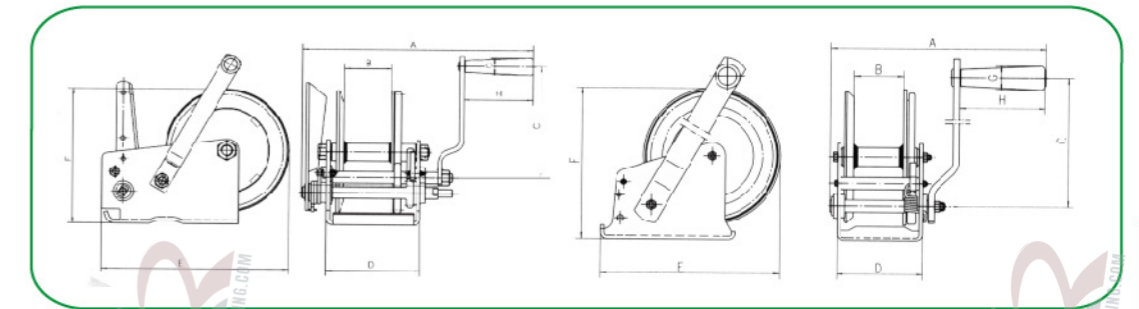
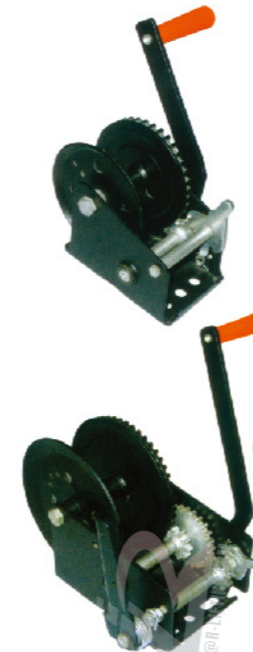

Model (LBS)	Test Load (KN)	Gear Ratio	Number of speeds	Dimensions(mm)								Net weight (KG)
				A	B	C	D	E	F	G	H	
600	4.00	2.9:1	single	232	51	180	88	165	138	25	90	2.5
800	5.34	3.7:1	single	232	51	180	88	165	138	25	90	2.6
1000	6.67	4.2:1	single	232	51	180	88	184	156	25	90	2.8
1200	8.00	4.2:1	single	232	51	180	88	184	156	25	90	2.8
1400	9.34	4.2:1	single	232	51	180	88	184	156	25	90	2.8
2000	13.35	10.35:1/4.5:1	Double	310	65	251	129.5	243	178	25	90	6.2
2500	16.68	11.5:1/5:1	Double	310	65	251	129.5	259	190	25	90	6.5

LIFTING EQUIPMENT

MODEL: CH ALUM . Ratchet Puller



Cable hoist designed to be used in industrial, construction and commercial applications. These durable high quality cable hoists are engineered for safe and easy operation. Cable hoist capacity 340kg~1800kg.

• Safety Features

Reversible aluminum handle is designed to bend for warning of hazardous overload. Superior 360 degrees drop forged swiveling hooks are equipped with safety latches. Meets ASME/ANSI standards B-30.21.

Double in terlocking precision die cast zinc alloy pawl system assures the engagement of one pawl at all times.

Pre-formed heavy duty, extra flexible, aircraft cable.

• Quality and Durability

Stainless steel spring and load bearing shafts resist corrosion. All rotating shafts are mounted on bronze bushings to reduce wear.

Rugged cast aluminum alloy housings are both light weight and dependable. Hard coated anodized aluminum cable guide provides extra abrasivenessistance.

• Easy to operate

Aluminum winding wheel for slack cable take up is standard on all models. Open construction allows for easy cleaning and inspection.

Double in terlocking pawl system assures precise control. Designed for teo-way, two-capacity rigging.

• Special Options

Stainless steel cable for Marine and high corrosion environments. Clevis and gate type hooks.

Model	0.34T	0.68T	0.68T	1.6T	0.9T	1.8T
Capacity(ton)	0.34	0.68	0.68	1.36	1.8	1.8
Test load(kn)	4.46	8.33	8.33	16.66	11	22
Lifting distance(m)	6	3	9	4.5	6	3
No.of cable falls	Single line	Double line	Single line	Double line	Single line	Double line
Max.handle pull on full load(n)	426	450	536	548	509	520
Hmin Min.distance between hooks(mm)	427	590	480	730	520	780
Steel wire model and specification	Single line breakong ≥13.3kn		Single line breakong ≥26.6kn		Single line breakong ≥35.3kn	
Net weight(kg)	3.45	3.85	5.7	6.4	6.2	7.1

LIFTING EQUIPMENT

MODEL: JC-E Heavy Duty Hand Winch

APPLICATIONS

JC-E type lever winch is a new model of manual winch. Compared with other winches, it is more convenient in use, more easy in operation and more widely use. It is mainly applied for cross-country vehicle, agriculture vehicle, pleasure-boat and other special vehicle.

It is the device of self-protection and pulling of vehicles and boats, and also may be used for saving in snowfield, marshland, desert, sea beach, muddy patch and other adverse

circumstances. It may be operated for clearing away obstacles, pulling material and installation.

It is the necessary safe device of mine, environment protection, forestry, transportation, fire fighting and other open field.

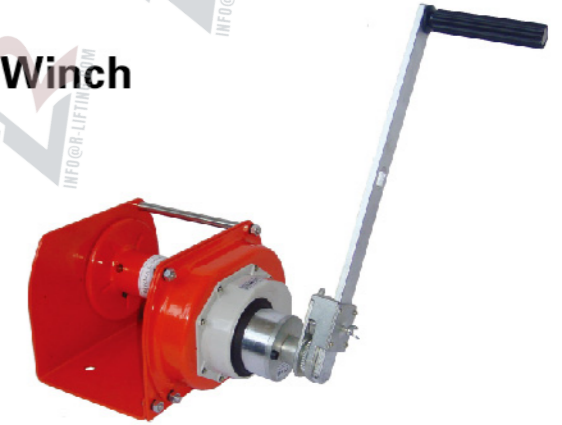

JC-E 0.5t 1t

CHARACTERISTICS

The main advantages of JC-E type lever winch in manufacturing and use are as follows:

- Adopting lever handle, either may shake operation along the whole circle, or may swing operation at any angle in the any position of circle. It has unique advantage in the narrow space.
- The gear box and braking mechanism are designed with sealed structure to avoid foreign matter entering the gear box and braking mechanism, and affect the normal operation.
- The braking material is made of environment material and is more suitable for the special area.
- The new brake pawl is designed for more better ensuring the stability of braking.
- The handle is adopted free structure to adjust the length of handle freely.
- The ratchet is big enough to contain more wire rope and more suitable for the operation in deep well and drawing of long distance.



JC-E 2t 3t

Model	0.5t	1t	2t	3t	
State Working Load(t)	0.5	1	2	3	
Running test load(KN)	6.125	12.25	24.5	36.75	
Adopted Wire Rope dia(mm)*length(m)	6.3*40	8*40	9*40	12.5*40	
Spee rattoo	4.33:1	12.19:1	22.68:1	29.16:1	
The Max.length of link-poleaction(mm)	350	350	350	350	
Min.force of hand turn(N)	120	120	130	180	
Dimensions(mm)	A	60	76	90	100
	B	140	175	190	230
	C	150	154	195	205
	D	100	110	155	155
	E	15	18	18	18
	F	403	443	490	549
	H	182	214	230	296
	I	130	170	170	170
	J	245	266	300	365
	Net.weight(KG)	14.4	19.7	25.1	44.3

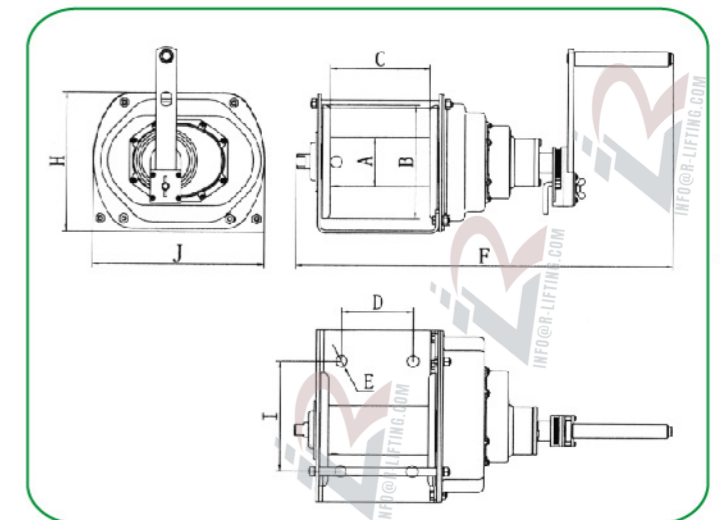

LIFTING EQUIPMENT

MODEL: WRP Ratchet Puller

MODEL 1000



MOVES 360°

Double Wire 5m/m x 2300

CAPACITY	MAX.L.	MIN.L.	WIRE DIA.	NET WT.
1 TON	1210m/m	410m/m	5m/m	3.2kg

MODEL 1500

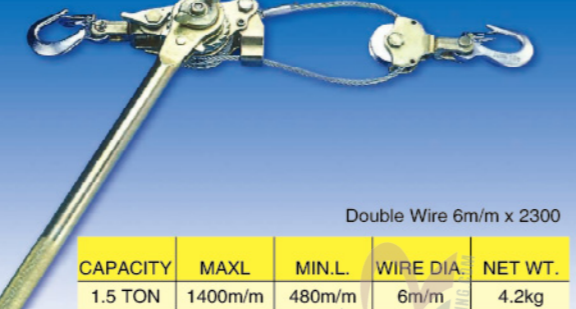

Double Wire 6m/m x 2300

CAPACITY	MAXL	MIN.L.	WIRE DIA.	NET WT.
1.5 TON	1400m/m	480m/m	6m/m	4.2kg

MODEL P1500

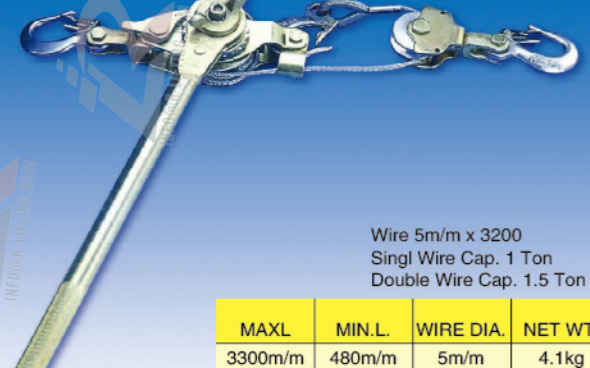

Wire 5m/m x 3200
Singl Wire Cap. 1 Ton
Double Wire Cap. 1.5 Ton

MAXL	MIN.L.	WIRE DIA.	NET WT.
3300m/m	480m/m	5m/m	4.1kg

MODEL 2000

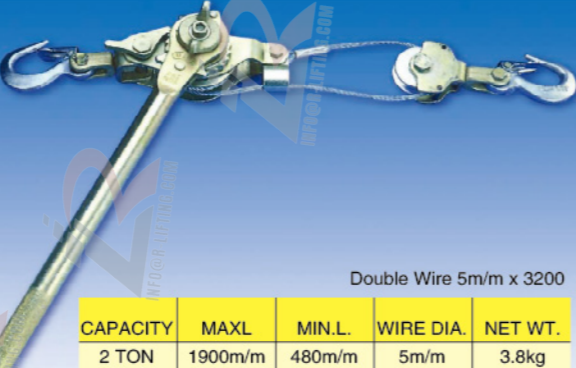

Double Wire 5m/m x 3200

CAPACITY	MAXL	MIN.L.	WIRE DIA.	NET WT.
2 TON	1900m/m	480m/m	5m/m	3.8kg

MODEL 1030



SD. Grip

Wire 5Φ x 2300

Wire 6Φ x 1200

CAPACITY	WEIGHT
1 TON	4.3kg

MODEL 1040

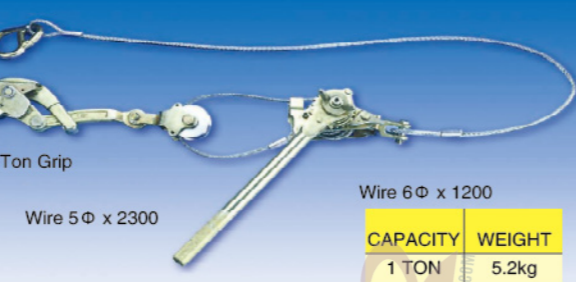

2 Ton Grip

Wire 5Φ x 2300

Wire 6Φ x 1200

CAPACITY	WEIGHT
1 TON	5.2kg

MODEL 1506



2 Ton Grip

Wire 6Φ x 2300

Wire 8Φ x 1200

CAPACITY	WEIGHT
1.5 TON	6.2kg

MODEL 1509



3 Ton Grip

Wire 6Φ x 2300

Wire 8Φ x 1300

CAPACITY	WEIGHT
1.5 TON	7.2kg

LIFTING EQUIPMENT

MODEL: WRG Wire Rope Grip



500G

MINI GRIP
Used for steel rod, messenger wire and barbed wire

Safe Load	Cable Diameter	W.T.
0.5 ton	1 ~ 10 m/m	0.4 kg



SD-L-1000C

SD-L-GRIP
Used for copper cable, covered conductor, steel rod, messenger wire and copper cable

Safe Load	Cable Diameter	W.T.
0.5 ton	2.6~15 m/m	0.75 kg



2000G

2 TON DOUBLE TOOTH GRIP
Double tooth strongly hold the wire without slippage

Safe Load	Cable Diameter	W.T.
2 ton	4 ~ 22 m/m	1.5 kg



S-2000

2 TON-L-GRIP
Model S-2000CL
Copper cable, covered conductor, and messenger wire
Model S-2000AL
Bare aluminum cable and A.C.S.R.

Safe Load	Cable Diameter	W.T.
2 ton	4 ~ 22 m/m	1.5 kg



2000

2 TON MEDIUM-L-GRIP
Model 2000MCL
Copper cable, covered conductor, and messenger wire
Model 2000MAL
Bare aluminum cable and A.C.S.R.

Safe Load	Cable Diameter	W.T.
2 ton	5 ~ 25 m/m	2.4 kg



S-3000

3 TON-L-GRIP
Model S-3000CL
Copper cable, covered conductor, and messenger wire
Model S-3000AL
Bare aluminum cable and A.C.S.R.

Safe Load	Cable Diameter	W.T.
3 ton	16 ~ 32 m/m	2.6 kg



3000

3 TON LARGE-L-GRIP
Model 3000MCL
Copper cable, covered conductor, and messenger wire
Model 3000MAL
Bare aluminum cable and A.C.S.R.

Safe Load	Cable Diameter	W.T.
3 ton	8 ~ 25 m/m	2.2 kg



S-4000

4 TON GRIP
Model S-4000CL
Copper cable, covered conductor, and messenger wire
Model S-4000AL
Bare aluminum cable and A.C.S.R.

Safe Load	Cable Diameter	W.T.
4 ton	20 ~ 35 m/m	3.8 kg

LIFTING EQUIPMENT

MODEL: HS Handling Of Small Tanks

Model	Capacity (t)	N0.of Wheel (PCS)	Length of link & Adjustable range (mm)	Shape dimension L*W*H(mm)	Net weight (kg)	
X4+Y4	X4	8	4	800	230×230×110	31
	Y4		4	300—1000	170×140×110	
X8+Y8	X8	16	8	1100	560×420×110	76
	Y8		8	400—1300	200×200×110	
X12+Y12	X12	24	12	1100	750×450×110	106
	Y12		12	400—1400	256×200×110	
X16+Y16	X16	32	16	1100	936×500×110	132
	Y16		16	400—1500	310×220×110	
X18+Y18	X18	36	18	1500	780×550×110	148
	Y18		18	400—1500	300×250×110	
X24+Y24	X24	48	24	1500	1000×580×120	200
	Y24		24	400—1600	360×315×120	
X32+Y32	X32	64	32	1500	1080×720×140	312
	Y32		32	500—2000	460×315×140	

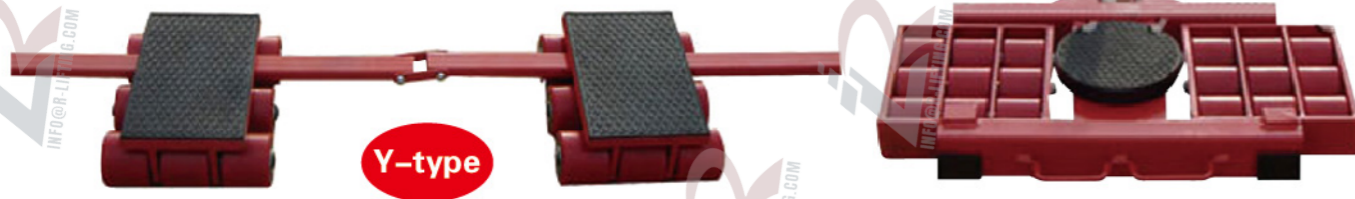

MODEL: CRA Tanks

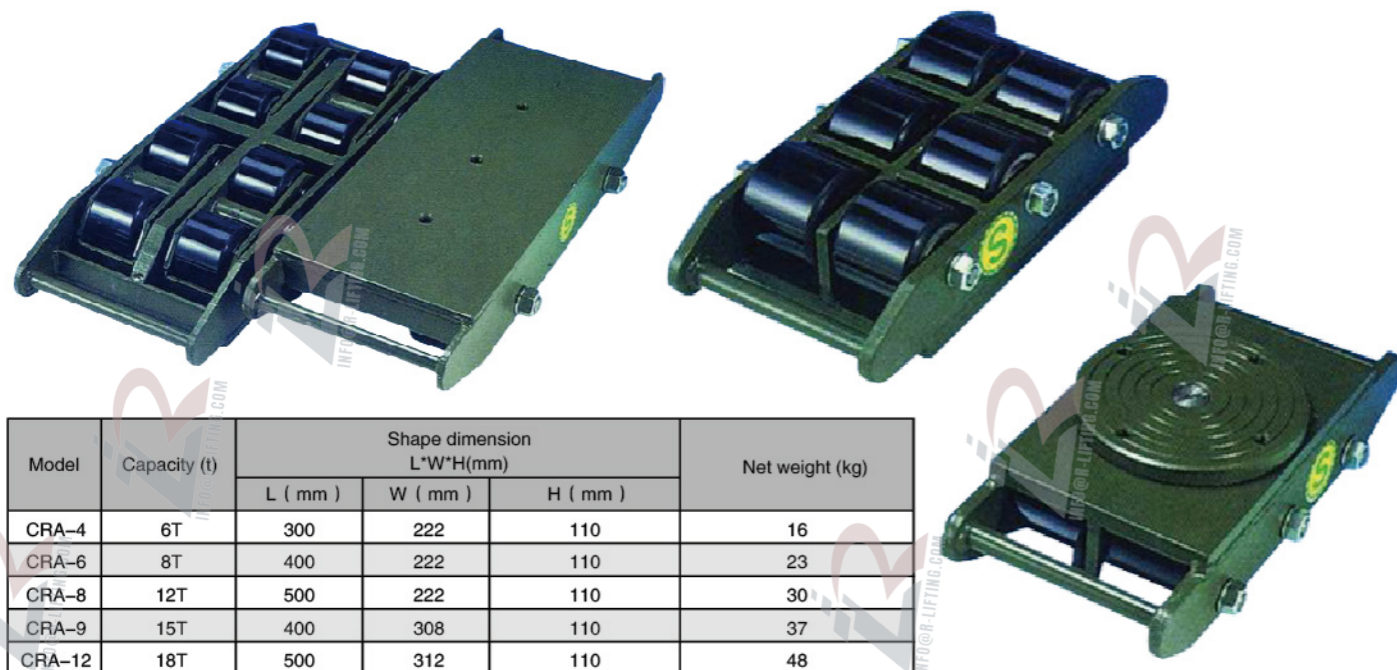

Model	Capacity (t)	Shape dimension L*W*H(mm)			Net weight (kg)
		L (mm)	W (mm)	H (mm)	
CRA-4	6T	300	222	110	16
CRA-6	8T	400	222	110	23
CRA-8	12T	500	222	110	30
CRA-9	15T	400	308	110	37
CRA-12	18T	500	312	110	48

LIFTING EQUIPMENT

MODEL: DL Permanent Magnetic Lifter

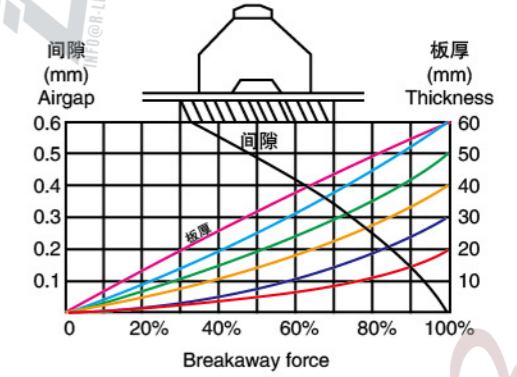
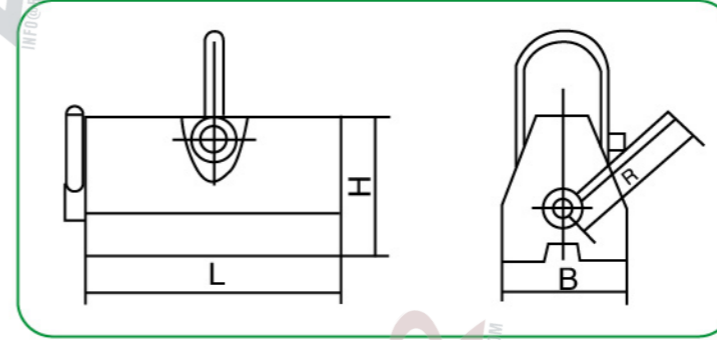

Model	Rated lifting capacity(kg)	Max. breakaway force(kg)	Dimensions(mm)				N.W. (kg)
			L	B	H	R	
DL-A100	100	300	90	63	68	145	3
DL-A400	400	1200	160	95	180	160	11
DL-A600	600	1800	220	115	125	230	20
DL-A1000	1000	3000	260	145	145	280	40
DL-A1500	1500	3750	310	145	145	280	48
DL-A2000	2000	5000	340	160	165	280	60
DL-A3000	3000	7500	420	185	185	410	90
DL-A4000	4000	10500	480	200	200	510	120
DL-A5000	5000	15000	580	300	300	650	400

MODEL: CL Permanent Magnetic Lifter

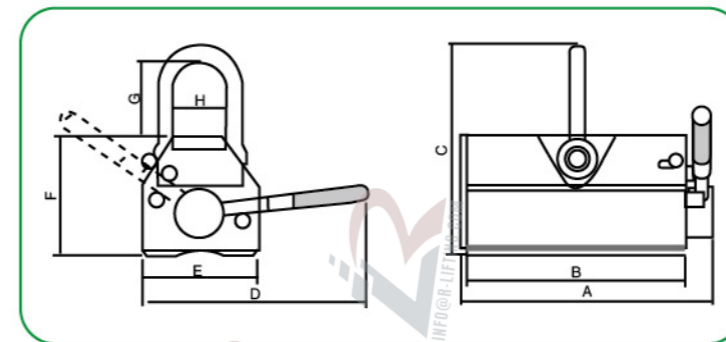

Model	Rated lifting capacity(kg)	Max. breakaway force(kg)	Dimensions(mm)								N.W. (kg)
			A	B	C	D	E	F	G	H	
CL-B100	100	220	107	84	120	125	60	71	41	30	3
CL-B300	300	660	180	155	156	185	90	93	51	41	11
CL-B600	600	1320	255	224	212	260	115	120	77	52	20
CL-B1000	1000	2200	280	245	286	371	165	169	97	87	40

LIFTING EQUIPMENT

MODEL: SBC → G80 Tie-down Chain



Model	Dia. (mm)	Length (Feet)	S.W.L. (Ton)	Breaking Load (Ton)	Net weight (Kgs)
SBC-0709	7.1	9	1.6	6.5	3.30
SBC-0712	7.1	12	1.6	6.5	4.20
SBC-0715	7.1	15	1.6	6.5	5.10
SBC-0718	7.1	18	1.6	6.5	6.30
SBC-0809	8	9	2	8	4.20
SBC-0812	8	12	2	8	5.50
SBC-0815	8	15	2	8	6.90
SBC-0818	8	18	2	8	8.50
SBC-1009	10	9	3.2	13.0	6.50
SBC-1012	10	12	3.2	13.0	8.50
SBC-1015	10	15	3.2	13.0	10.50
SBC-1018	10	18	3.2	13.0	13.20
SBC-1309	13	9	5.5	22.0	10.80
SBC-1312	13	12	5.5	22.0	14.10
SBC-1315	13	15	5.5	22.0	17.40
SBC-1318	13	18	5.5	22.0	21.60

MODEL: T-8 → For Hoist Load Chain



Size d	Diameter Tolerance MM	Pitch t MM	Inside Width d1 ≥ MM	Outside Width d2 ≤ MM	Working Load T	Test Load KN	Breaking Load KN	KG/M (Approx)
4	±0.1	12	4.8	13.6	0.5	13	20	0.35
5	±0.1	15	6	17	0.8	20	31	0.54
6	±0.2	18	7.2	20.4	1	28	45	0.79
6.5	±0.2	19.5	7.8	22.1	1.2	33	53	0.95
7	±0.2	21	8.4	23.8	1.6	38	62	1.05
8	±0.3	24	9.6	27.2	2	50	80	1.38
10	±0.3	30	12	34	3.2	79	126	2.2
12	±0.4	36	14.4	40.8	5	113	181	3.3
13	±0.4	39	15.6	44.2	5.3	133	212	3.7
16	±0.5	48	19.2	54.4	8	201	322	5.6
18	±0.5	54	21.6	61.2	10	254	407	7
19	±0.6	57	22.8	64.6	11.2	284	454	8.1
20	±0.6	60	24	68	12.5	314	503	8.7
22	±0.7	66	26.4	74.8	15	380	608	10.5
23	±0.7	69	27.6	78.2	16	415	665	12
25	±0.8	75	30	85	20	491	785	14.1
26	±0.8	78	31.2	88.4	21.2	531	849	15.2

MODEL: DL → Drum Lifter



Model	Working load limit		Proof Test Load	Dimensions (MM)			Reach (MM)	Weight kg
	Single	Double		Diameter	Length	Dia.		
DL	500kg	1000kg	2000kg	6.3	516	13	690	3.6

LIFTING EQUIPMENT

MODEL: JQ-A → Handle-type Mechanical Jack

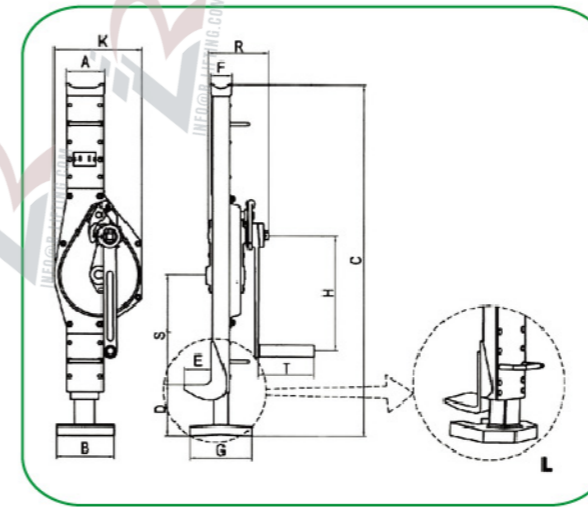
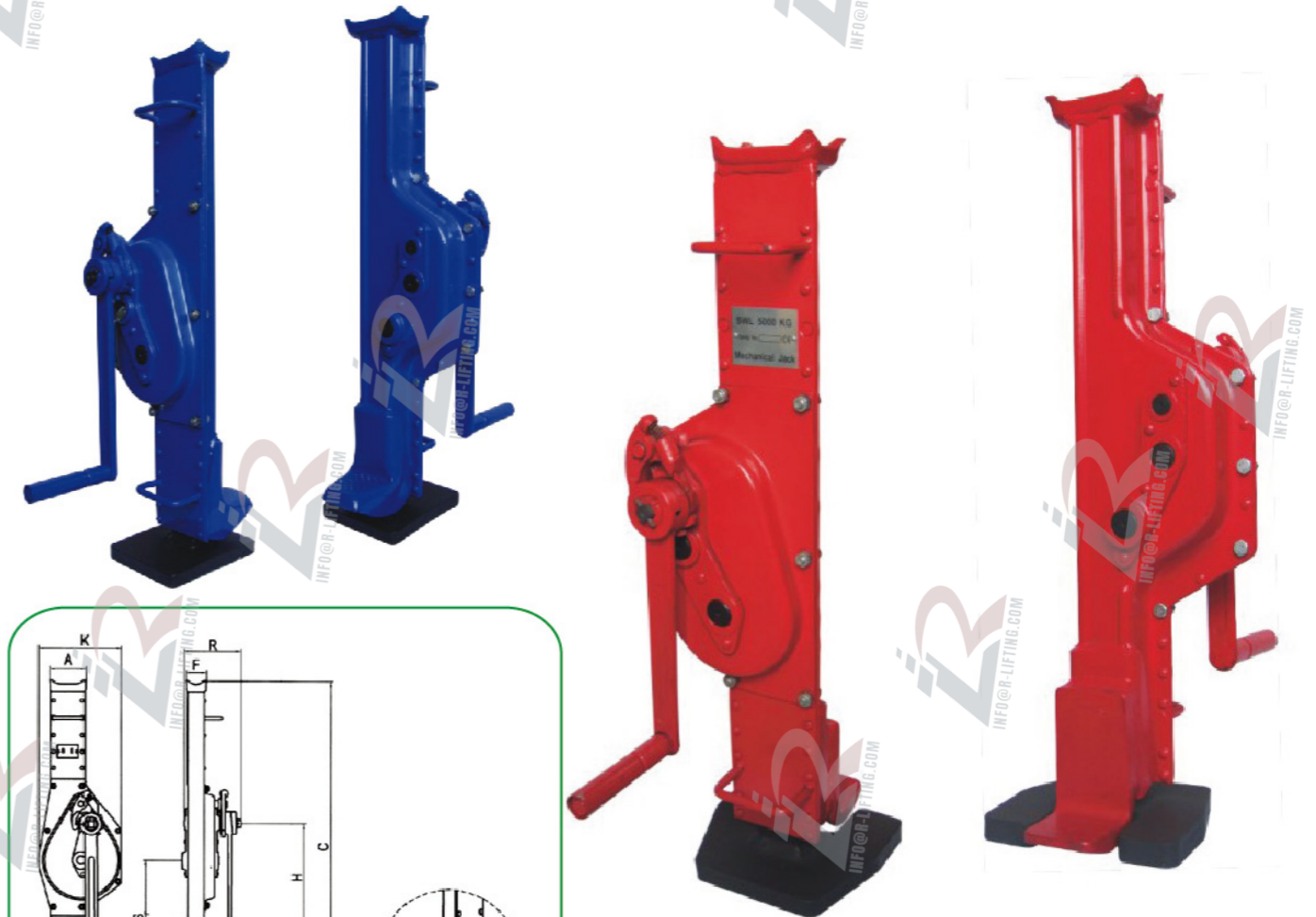

Model	1.5 t	3 t	5 t	10 t	16 t	20 t	25 t	
Capacity(kg)	1500	3000	5000	10000	16000	20000	25000	
Running test load(kN)	18.4	36.8	61.3	122.5	196	245	306	
Chain shake to lift full load (N)	150	280	280	560	640	640	640	
Headroom(drawn close-up)Hmin(MM)	300	350	350	410	320	320	320	
Dimensions(mm)	A	77	83	105	120	153	153	
	B	100	130(165)	145(200)	145(220)	150	150	198
	C	605-905	715-1085	730-1080	795-1160	820-1140	865-1180	950-1360
	D	55-355	60-430 (20-430)	70-420 (30-420)	83-448 (30-448)	135-455	125-440	110-520
	E	55	60(50)	70(60)	80(75)	85	85	85
	F	40	45	68	73	90	90	90
	G	110	135(130)	170	170	182	182	230
	H	225	285	285	330	360	360	360
	K	121	200	190	252	275	275	388
	R	119	140	155	185	210	224	200
	S	185	230(270)	220(280)	220(280)	202	202	205
T	126	126	126	255	255	255	255	
Net weight(kg)	10.7	21.3(24.5)	27(30)	47(53)	64.5	72	93	



PE & PP ROPE



PE & PP ROPE

PP TWISTED ROPE

PP MONOFILAMENT ROPE



Material:PP(Polypropylene)
Size:4-30mm
Structure:3-strand or 4-strand
Color:as per your request
Packing:coil,hank,bundle,reel

PP MULTIFILAMENT ROPE



Material:PP(Polypropylene)
Size:4-60mm
Structure:3-strand or 4-strand
Color:as per your request
Packing:coil,hank,bundle,reel

BRAIDED ROPE

8-STRAND BRAIDED ROPE



Material:PE,PP,POLYESTER,NYLON,COTTON
Size:3-20mm
Structure:8-strand
Color:as per your request
Packing:coil,hank,bundle,reel

16-STRAND BRAIDED ROPE



Material:PE,PP,POLYESTER,NYLON,COTTON
Size:3-30mm
Structure:16-strand
Color:as per your request
Packing:coil,hank,bundle,reel

BRAIDED & PE MARK ROPE

8-STRAND HAWSER

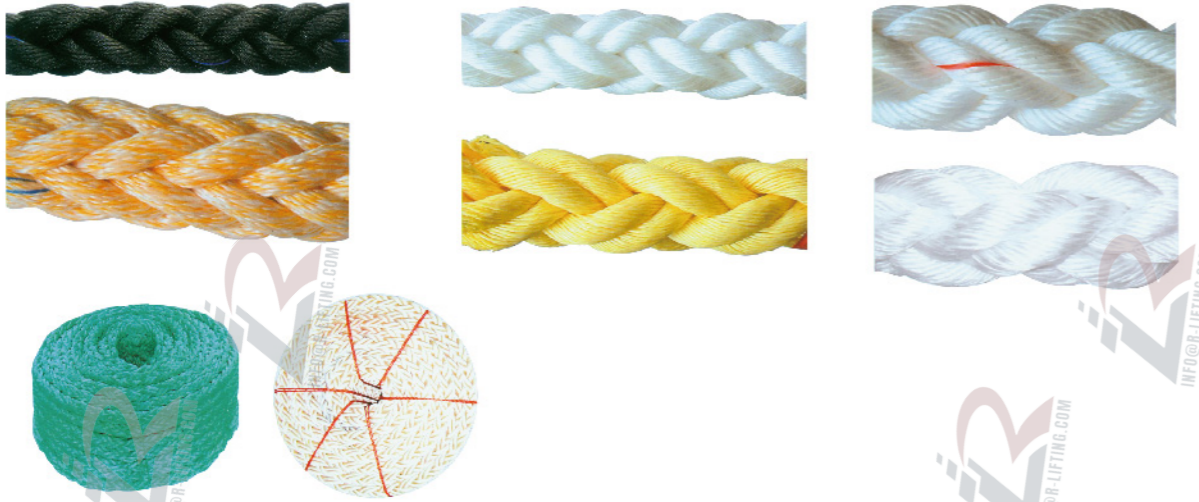

Material: PE, PP, POLYESTER, NYLON
 Size: 40-120mm
 Structure: 8-strand
 Color: as per your request
 Packing: coil

PE MARK ROPE

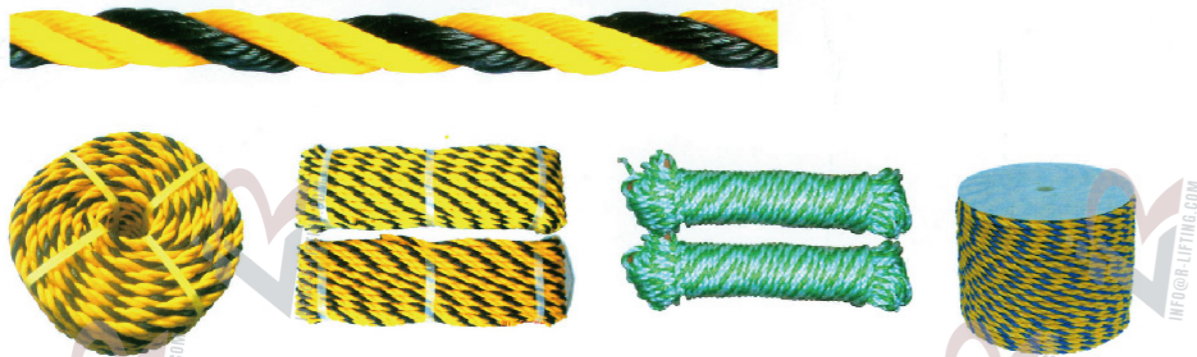

Material: HDPE (Polyethylene)
 Size: 6-20mm
 Structure: 3-strand or 4-strand
 Color: as per your request
 Packing: coil, hank, bundle, reel

Standard Specification of Rope

3,4 & 8-STRAND ROPE

Size			Pol Ypropylene (ISO1346:1990-E)		Pol Yethylene (ISO1969:1990E)		Nylon (ISO1140:1990-E)		Pol Yester (ISO1141:1990-E)		Vinylon (Kurolon KS)		Manila (ISO1181:1990E)	
Dia (mm)	Dia (inch)	Cir (inch)	Weight (kg/220m)	MBL (kgf or Tons)	Weight (kg/220m)	MBL (kgf or Tons)	Weight (kg/220m)	MBL (kgf or Tons)	Weight (kg/220m)	MBL (kgf or Tons)	Weight (kg/220m)	MBL (kgf or Tons)	Weight (kg/220m)	MBL (kgf or Tons)
4	5/32	1/2	1.32	215kgf	1.78	200kgf	2.31	320kgf	2.6	295kgf	2.2	150kgf	3	190kgf
5	3/16	5/8	2.45	320	2.66	300	3.6	500	4.1	400	3.4	230	4	240
6	7/32	3/4	3.74	600	4	400	4.95	750	6	565	5	330	6.4	285
7	1/4	7/8	5.1	750	5.5	550	6.7	1020	8.2	770	6.8	430	7.7	370
8	5/16	1	6.6	1060	7.2	700	8.8	1350	10.6	1020	8.8	560	11.9	545
9	11/32	1-1/8	8.1	1190	9	890	11.2	1700	13.5	1270	11	700	14	620
10	3/8	1-1/4	9.9	1560	10.8	1090	13.6	2080	16.7	1590	13.6	950	15	705
12	1/2	1-1/2	14.3	2210	15.8	1540	19.6	3000	24.2	2270	19.8	1370	23.1	1070
14	9/16	1-3/4	20	3050	21	2090	27	4100	32.6	3180	26.4	1830	30.8	1460
16	5/8	2	25.3	3.78Ts	28	2.8Ts	35	5.3Ts	43	4.1Ts	35.2	2.34Ts	41.8	2.03Ts
18	3/4	2-1/4	32.5	4.82	35	3.5	44	6.7	54	5.15	44	2.92	48.4	2.44
20	13/16	2-1/2	40	5.8	44	4.3	54	8.3	67	6.4	53.9	3.55	60.5	3.25
22	7/8	2-3/4	48.4	6.96	53	5.1	66	10	81	7.6	64.9	4.24	72.6	3.66
24	1	3	57	8.13	65	6.1	78	12	96	9.1	78	5	88	4.57
26	1-1/16	3-1/4	67	9.41	72	7	92	14	113	10.7	91	5.8	103	5.33
28	1-1/8	3-1/2	78	10.7	86	8.2	107	15.8	131	12.2	106	6.64	117	6.1
30	1-1/4	3-3/4	89	12.22	101	9.5	122	17.8	150	13.7	120	7.6	138	6.9
32	1-5/16	4	101	13.5	115	10.7	139	20	171	15.7	136	8.51	154	7.9
34	1-3/8	4-1/4	115	14.4	130	11.6	156	22	192	17.4	154	9.53	176	8.8
36	1-7/16	4-1/2	129	16.93	145	13.4	176	24.9	216	19.4	173	10.6	196	9.65
38	1-9/16	4-3/4	142	17.7	160	14.3	195	27.4	243	21.6	193	11.7	220	10.8
40	1-5/8	5	158	20.51	173	16.3	218	30	267	24	213	12.9	242	12
42	1-11/16	5-1/4	176	21.4	191	17.2	238	32.9	295	26.1	234	14.1	270	13.1
44	1-3/4	5-1/2	194	24.64	209	19.6	264	35.8	323	28.5	258	15.3	295	14.28
46	1-7/8	5-3/4	211	25.3	230	20.6	310	38.9	354	30.9	282	16.7	323	15.5
48	1-15/16	6	229	28.61	253	22.8	312	42	385	33.6	306	18	348	16.83
50	2	6-1/4	248	29.3	275	24.3	339	45.4	418	36.3	332	19.5	382	18.2
52	2-1/8	6-1/2	268	33.11	297	26.4	365	48.9	451	39.2	359	21.1	411	19.59
54	2-3/16	6-3/4	290	33.7	320	28.2	393	52.4	483	41.9	376	22.5	446	20.6
56	2-1/4	7	312	37.86	345	30.4	425	56	524	44.8	405	24.2	473	22.4
58	2-5/16	7-1/4	335	38.6	370	32.2	454	59.9	563	47.2	445	25.6	514	23.5
60	2-3/8	7-1/2	359	43.29	396	34.4	486	63.9	601	49.9	476	27.4	546	25.4
64	2-1/2	8	407	48.96	451	39.1	554	72	684	58	542	30.8	634	29
72	2-7/8	9	515	61.5	570	49.1	702	90	865	72.1	686	38.6	796	35.8
80	3-1/4	10	638	75.64	706	60.4	867	110	1067	88.5	844	46.8	968	43.6
88	3-1/2	11	772	90.77	853	72.5	1049	131	1291	106	1023	55.6	1177	51.5
96	3-3/4	12	916	107	1014	85.5	1250	154	1538	126	1214	65.8	1408	60
104	4-1/8	13	1078	122.9	1190	100.3	1465	182	1804	145				
112	4-1/2	14	1254	141.84	1380	116.3	1698	210	2090	165				
120	4-3/4	15	1430	162.86	1584	133.5	1951	240	2398	190				

*Available Size:
 3-Strand Rope: Φ4mm~60mm
 4-Strand Rope: Φ6mm~60mm
 8-Strand Rope: Φ32mm~120mm

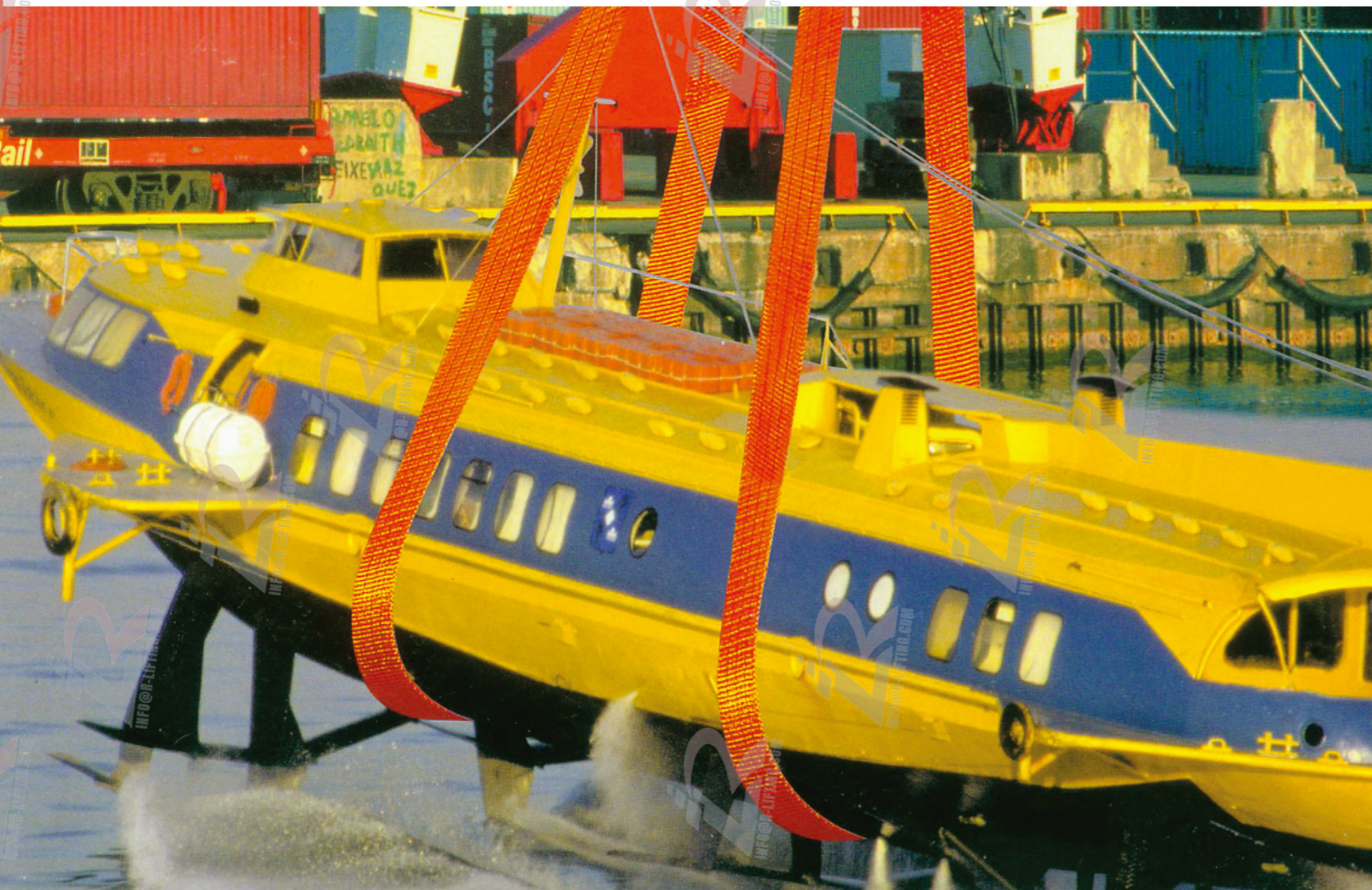

WEBBING SLING

Flat Webbing Sling

1. 100% High tensile polyester material
2. According to EN1492-1:2000
3. With reinforced lifting eyes
4. Safety factor 7:1
5. Low elongation
6. Wear resistant
7. Length available: 1M up to 10M
8. Other safety factors available: 5:1, 6:1, 8:1
9. Single ply or double plies

Lifting eye types

Flat eye	
Reversed eye	
Folded eye width from 1 side	
Folded eye width from 2 side	
Folded eye 1/3 width	

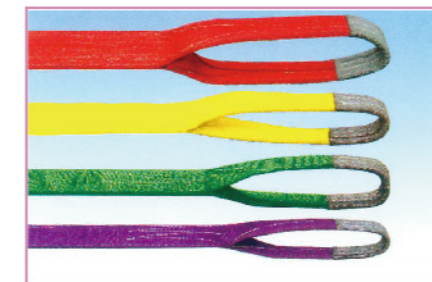

Webbing width (mm)	Colour coded according to EN 1492-1	Working load limited with 1 webbing sling (kgs)					Working load limited with 2 webbing sling (kgs)			
		Straight lift	Choked lift	β			Straight lift up to 45°	Choked lift up to 45°	Straight lift 45-60°	Choked lift 45-60°
				0° -7°	7° -45°	45° -60°				
		1.0	0.8	2.0	1.4	1.0	1.4	1.12	1.0	0.8
25	WLL1T	1.000	8.000	2.000	1.400	1.000	1.400	1.120	1.000	8.000
50	WLL2T	2.000	1.600	4.000	2.800	2.000	2.800	2.240	2.000	1.600
75	WLL3T	3.000	2.400	6.000	4.200	3.000	4.200	3.360	3.000	2.400
100	WLL4T	4.000	3.200	8.000	5.600	4.000	5.600	4.480	4.000	3.200
125	WLL5T	5.000	4.000	10.000	7.000	5.000	7.000	5.600	5.000	4.000
150	WLL6T	6.000	4.800	12.000	8.400	6.000	8.400	6.720	6.000	4.800
200	WLL8T	8.000	6.400	16.000	11.200	8.000	11.200	8.960	8.000	6.400
250	WLL10T	10.000	8.000	20.000	14.000	10.000	14.000	11.200	10.000	8.000

WEBBING SLING

Endless Webbing Sling

1. 100% High tensile polyester material
2. Safety factor available 2:1,5:1,6:1,7:1
3. Low elongation
4. Wear resistant
5. Length available: 1M up to 10M
6. Single ply or double plies

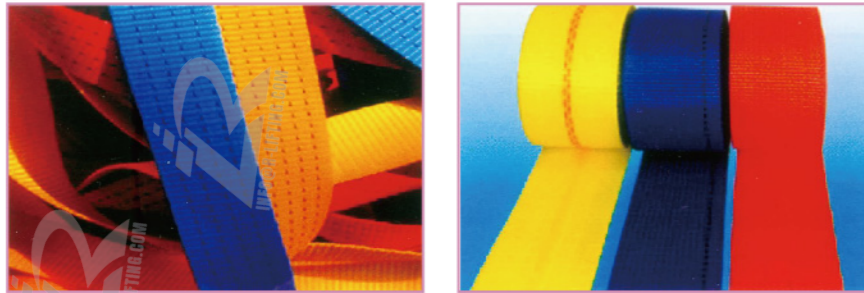

Webbing width (mm)	Colour coded according to EN 1492-1	Working load limited with 1 webbing sling (kgs)						Working load limited with 2 webbing sling (kgs)				
		Straight lift	Choked lift	β				Straight lift up to 45°	Choked lift up to 45°	Straight lift 45-60°	Choked lift 45-60°	
				0° -7°	7° -45°	45° -60°	up to 45°					45° -60°
		1.0	0.8	2.0	1.4	1.0	0.7	0.5	1.4	1.12	1.0	0.8
30	WLL1T	1.000	800	2.000	1.400	1.000	0.700	0.500	1.400	1.120	1.000	8.00
60	WLL2T	2.000	1.600	4.000	2.800	2.000	1.400	1.000	2.800	2.240	2.000	1.600
90	WLL3T	3.000	2.400	6.000	4.200	3.000	2.100	1.500	4.200	3.360	3.000	2.400
120	WLL4T	4.000	3.200	8.000	5.600	4.000	2.800	2.000	5.600	4.480	4.000	3.200
140	WLL5T	5.000	4.000	10.000	7.000	5.000	3.500	2.500	7.000	5.600	5.000	4.000
180	WLL6T	6.000	4.800	12.000	8.400	6.000	4.200	3.000	8.400	6.720	6.000	4.800
240	WLL8T	8.000	6.400	16.000	11.200	8.000	5.600	4.000	11.200	8.960	8.000	6.400
300	WLL10T	10.000	8.000	20.000	14.000	10.000	8.400	6.000	14.000	11.200	10.000	8.000

Webbing width (mm)	Colour coded according to EN 1492-1	Working load limited with 1 webbing sling (kgs)						Working load limited with 2 webbing sling (kgs)				
		Straight lift	Choked lift	β				Straight lift up to 45°	Choked lift up to 45°	Straight lift 45-60°	Choked lift 45-60°	
				0° -7°	7° -45°	45° -60°	up to 45°					45° -60°
		1.0	0.8	2.0	1.4	1.0	0.7	0.5	1.4	1.12	1.0	0.8
25	WLL1T	1.000	800	2.000	1.400	1.000	0.700	0.500	1.400	1.120	1.000	8.00
50	WLL2T	2.000	1.600	4.000	2.800	2.000	1.400	1.000	2.800	2.240	2.000	1.600
75	WLL3T	3.000	2.400	6.000	4.200	3.000	2.100	1.500	4.200	3.360	3.000	2.400
100	WLL4T	4.000	3.200	8.000	5.600	4.000	2.800	2.000	5.600	4.480	4.000	3.200
125	WLL5T	5.000	4.000	10.000	7.000	5.000	3.500	2.500	7.000	5.600	5.000	4.000
150	WLL6T	6.000	4.800	12.000	8.400	6.000	4.200	3.000	8.400	6.720	6.000	4.800
200	WLL8T	8.000	6.400	16.000	11.200	8.000	5.600	4.000	11.200	8.960	8.000	6.400
250	WLL10T	10.000	8.000	20.000	14.000	10.000	8.400	6.000	14.000	11.200	10.000	8.000

WEBBING SLING

Round Sling

1. 100% High tensile polyester material
2. According to EN1492-1:2000
3. Safety factor 7:1
4. Each stripe is equal to 1 ton capacity
5. Low elongation
6. Flexible and wear resistant
7. Length available: 1M up to 10M
8. Other safety factors available: 5:1, 6:1, 8:1
9. Single ply or double plies sleeves

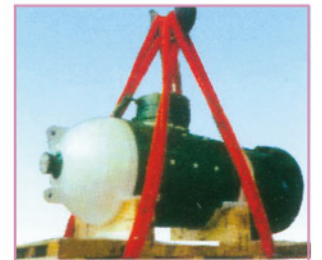
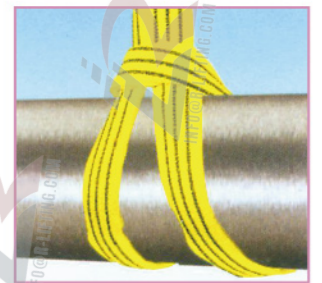

Colour	Colour coded according to EN 1492-1	Working load limited with 1 webbing sling (kgs)						Working load limited with 2 webbing sling (kgs)				
		Straight lift	Choked lift	β				Straight lift up to 45°	Choked lift up to 45°	Straight lift 45-60°	Choked lift 45-60°	
				0° -7°	Bis7°	7° -45°	45° -60°					45° -60°
		1.0	0.8	2.0	1.4	1.0	0.7	0.5	1.4	1.12	1.0	0.8
紫色	WLL1T	1.000	800	2.000	1.400	1.000	0.700	0.500	1.400	1.120	1.000	8.00
綠色	WLL2T	2.000	1.600	4.000	2.800	2.000	1.400	1.000	2.800	2.240	2.000	1.600
黃色	WLL3T	3.000	2.400	6.000	4.200	3.000	2.100	1.500	4.200	3.360	3.000	2.400
灰色	WLL4T	4.000	3.200	8.000	5.600	4.000	2.800	2.000	5.600	4.480	4.000	3.200
紅色	WLL5T	5.000	4.000	10.000	7.000	5.000	3.500	2.500	7.000	5.600	5.000	4.000
棕色	WLL6T	6.000	4.800	12.000	8.400	6.000	4.200	3.000	8.400	6.720	6.000	4.800
藍色	WLL8T	8.000	6.400	16.000	11.200	8.000	5.600	4.000	11.200	8.960	8.000	6.400
桔黃	WLL10T	10.000	8.000	20.000	14.000	10.000	7.000	5.000	14.000	11.200	10.000	8.000
桔黃	WLL12T	12.000	9.600	24.000	16.800	12.000	8.400	6.000	16.800	13.440	12.000	9.600

WEBBING SLING

Jacket Sling

Round Sling is covered with the jacket to protect the inside of ropes and prevent damaging.



Guard

Guard as method of perfect protection could be applied to Rope as well as Roundsling. Guard will prevent Rope as well as Roundsling from abrasion and the life time of ropes and sling will be longer with perfection.



Safety Self-Check Sling

Safety Self-Check sling with Ultra High Molecular Weight Polyethylene(UHMWPE) could check the life time of Round Sling.

- Melting Point : 150°C
- Temperature Range for USE : -40°C to 70°C
- Elongation at Break : 4 ~ 5%
- Specific Gravity : 0.97 (Float)
- Water Proportion : None (Wet strength equals Dry strength)
- Strongest fiber rope, maximum strength to weight ratio and strength comparable to steel wire rope.

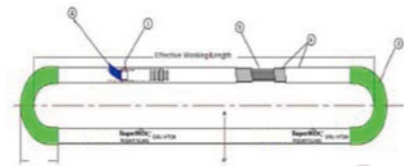

Cargo Lashings

Lasing system 25A



Lasing system 35B

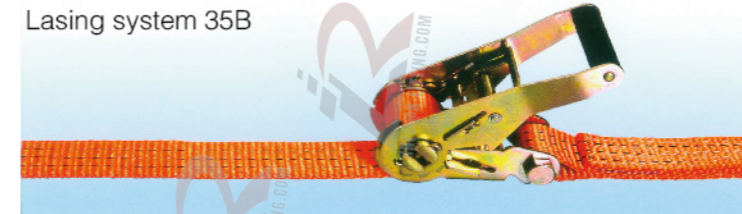

Lasing system 50B

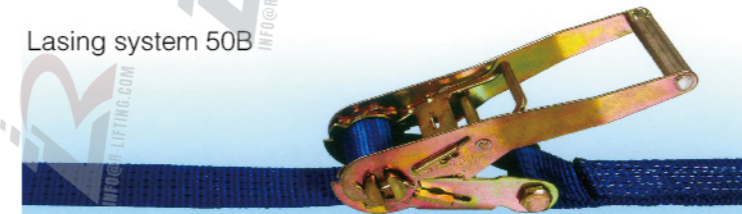

Part No.	Type	Lashing capacity(LC)in accordance with EN 12195-2(daN)	Webbing width (mm)	End fittings(No.)
HQCL25A2	25A/2	300	25	2,3,4,5
HQCL25A1	25A/1	300	25	环形 Loop
HQCL25B2	25B/2	500	25	2,3,4,5
HQCL25B1	25B/1	500	25	环形 Loop
HQCL35A2	35A/2	1000	35	1,2
HQCL35A1	35A/1	1000	35	环形 Loop
HQCL35B2	35B/2	1500	35	1,3,6,8,9,10
HQCL35B1	35B/1	1500	35	环形 Loop
HQCL50A2	50B/2	2000	50	1,3,4,6,8,9,10
HQCL50A1	50B/1	2000	50	环形 Loop
HQCL50B2	50A/2	2500	50	1,3,6,8,9,10
HQCL50B1	50A/1	2500	50	环形 Loop
HQCL75A2	75/2	5000	75	1,2,6,10
HQCL75A1	75/1	5000	75	环形 Loop
HQCL100B2	100/2	5000	100	1,2,6,10
HQCL100B1	100/1	5000	100	环形 Loop

Cargo Lashings

0.8t, 25-08-4m

Lashing Capacity(LC)

25mm Cam buckle
Length:4m

400kgs 
800kgs 



1t, 25-10-6m

Lashing Capacity(LC)

25mm Ratchet buckle, Double J hooks
Length:6m



500kgs 
1000kgs 



1t, 25-10-4m

Lashing Capacity(LC)

25mm Ratchet buckle, S hooks
Length:4m



500kgs 
1000kgs 



1.5t, 25-15-6m

Lashing Capacity(LC)

25mm Ratchet buckle, S hooks
Lenth:6m

750kgs 
1500kgs 



1.5t, 25-10-6m

Lashing Capacity(LC)

25mm Ratchet buckle, S hooks
Length:6m

500kgs 
1000kgs 

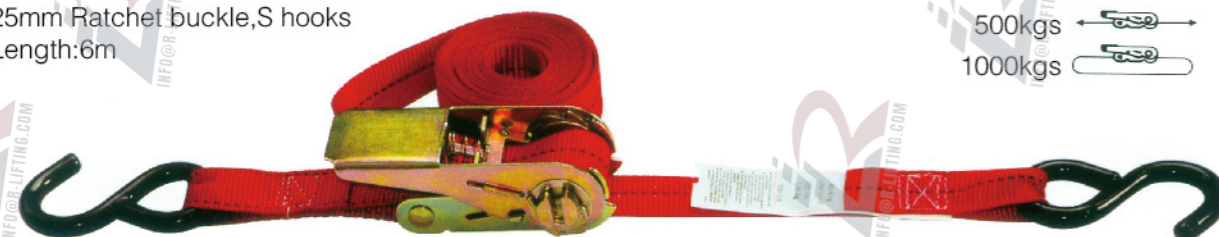



Cargo Lashings

2t, 35-20-6m

Lashing Capacity(LC)

35mm Ratchet buckle,
Double J hooks
Length:6m



1000kgs 
2000kgs 



3t, 35-30-6m

Lashing Capacity(LC)

35mm Ratchet buckle, Single hooks
Length:6m

1500kgs 
3000kgs 



5t, 50J-50-4m

Lashing Capacity(LC)

50mm Ratchet buckle,
Single hook and swivel hook
Length:4m

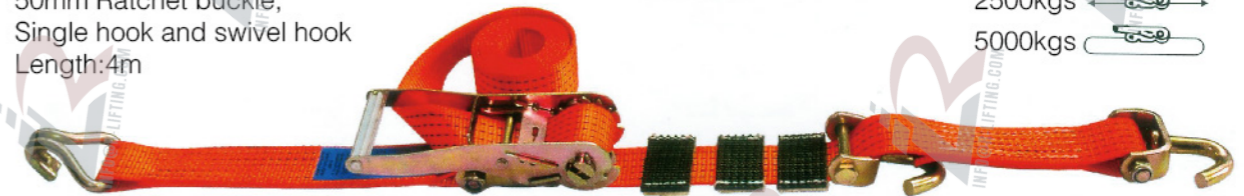

2500kgs 
5000kgs 



4t, 50E-40-8m 50-40-8m

Lashing Capacity(LC)

50mm Ratchet buckle, E spring fittings
Length:8m

2000kgs 
4000kgs 



5t, 50-50-9m

Lashing Capacity(LC)

50mm Reverse Ratchet buckle,
Hooks and keepers
Length:9m

2500kgs 
5000kgs 



5t, 50-50-10m

Lashing Capacity(LC)

50mm Ratchet buckle, Double J Hooks
Length:10m

2500kgs 
5000kgs 

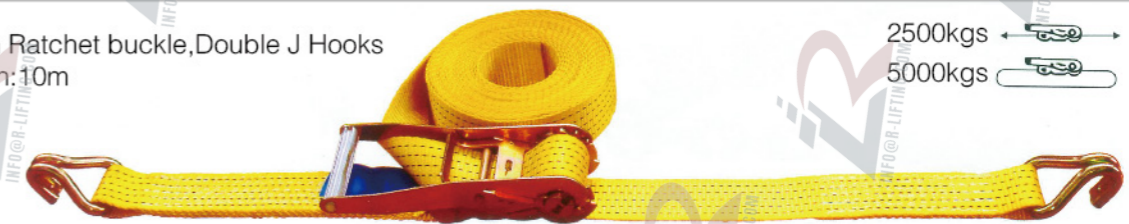

ANCHOR CHAIN

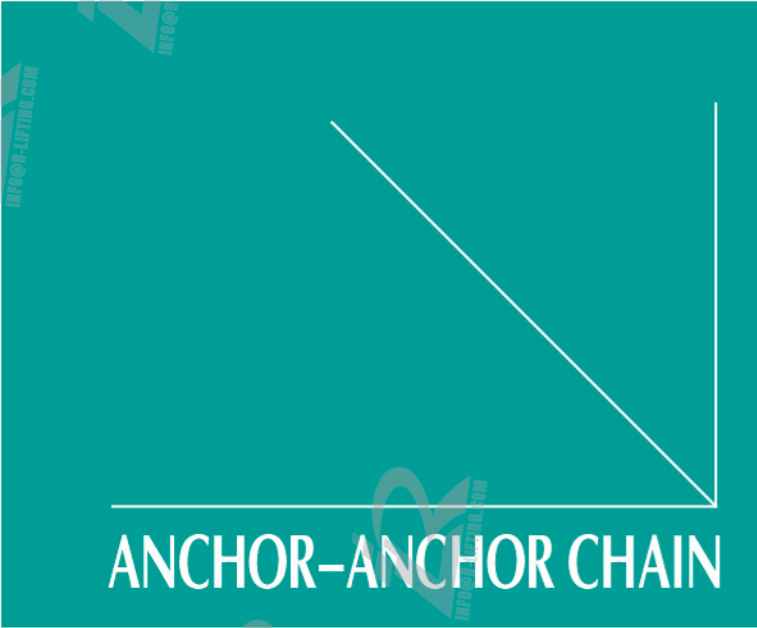

ANCHOR-ANCHOR CHAIN



Testing Load of Anchor Chain and Accessories & Mooring Chain

Diameter of Chain	Anchor Chain						Offshore Mooring Chain									
	ABS, BV, CCS, CR, DNV, GL, KR, LR, NK, RINA, RMRS						API	ABS/DNV			ABS/DNV			ABS/DNV		
	Grade2		Grade3		ORQ			C/EL/E	DNV ABS C/EL/E SL	ABS/DNV C/EL/E SL	C/EL/E	SL	C/EL/E SL	C/EL/E	SL	C/EL/E SL
	PL C=0.098	BL C=0.0137	PL C=0.0137	BL C=0.0196	PL C=0.014	BL C=0.0211	PL C=0.0148	PL C=0.0156	BL C=0.0223	PL C=0.0180	PL C=0.0174	BL C=0.0249	PL C=0.0216	PL C=0.0192	BL C=0.0274	
mm	KN	KN	KN	KN	KN	KN	KN	KN	KN	KN	KN	KN	KN	KN	KN	KN
12.5	66	92	92	132												
14	82	116	116	165	-	-	-	-	-	-	-	-	-	-	-	-
16	107	150	150	216	-	-	-	-	-	-	-	-	-	-	-	-
17.5	127	179	179	256	-	-	-	-	-	-	-	-	-	-	-	-
19	150	211	211	301	-	-	-	-	-	-	-	-	-	-	-	-
20.5	175	244	244	349	-	-	-	-	-	-	-	-	-	-	-	-
22	200	280	280	401	-	-	-	-	-	-	-	-	-	-	-	-
24	237	332	332	476	-	-	-	-	-	-	-	-	-	-	-	-
26	278	389	389	556	-	-	-	-	-	-	-	-	-	-	-	-
28	321	449	449	642	-	-	-	-	-	-	-	-	-	-	-	-
30	368	514	514	735	-	-	-	-	-	-	-	-	-	-	-	-
32	417	583	583	833	-	-	-	-	-	-	-	-	-	-	-	-
34	468	655	655	937	668	1007	706	745	1064	859	831	1188	1031	916	1308	
36	523	732	732	1050	746	1124	789	832	1189	960	928	1327	1151	1022	1460	
38	581	812	812	1160	828	1248	876	923	1319	1065	1029	1473	1278	1135	1621	
40	640	896	896	1280	914	1376	967	1019	1456	1176	1136	1626	1411	1253	1789	
42	703	981	981	1400	999	1513	1056	1114	1592	1285	1242	1777	1542	1370	1956	
44	769	1080	1080	1540	1097	1654	1160	1223	1748	1411	1364	1951	1693	1503	2147	
46	837	1170	1170	1680	1194	1800	1263	1331	1902	1535	1484	2124	1843	1636	2337	
48	908	1270	1270	1810	1295	1952	1369	1443	2063	1665	1610	2304	2037	1775	2535	
50	981	1370	1370	1960	1400	2110	1480	1561	2230	1800	1743	2490	2160	1918	2740	
52	1060	1480	1480	2110	1508	2273	1594	1682	2402	1939	1877	2682	2327	2066	2952	
54	1140	1590	1590	2270	1620	2441	1712	1806	2580	2083	2017	2881	2499	2219	3170	
56	1220	1710	1710	2430	1735	2615	1834	1935	2764	2231	2160	3086	2677	2378	3396	
58	1290	1810	1810	2600	1851	2794	1960	2068	2953	2383	2308	3297	2860	2540	3628	
60	1380	1940	1940	2770	1976	2978	2089	2203	3147	2540	2406	3514	3048	2708	3867	
62	1470	2060	2060	2940	2101	3166	2221	2343	3347	2701	2616	3737	3242	2879	4112	
64	1560	2190	2190	3130	2230	3360	2357	2486	3551	2867	2776	3965	3440	3055	4364	
66	1660	2310	2310	3300	2361	3559	2496	2633	3761	3036	2940	4200	3643	3235	4621	
68	1750	2450	2450	3500	2496	3762	2639	2784	3976	3209	3108	4440	3851	3420	4885	
70	1840	2580	2580	3690	2631	3970	2785	2938	4196	3387	3289	4685	4064	3610	5156	

ANCHOR CHAIN

ANCHOR CHAIN

Testing Load of Anchor Chain and Accessories & Mooring Chain

Diameter of Chain	Anchor Chain				Offshore Mooring Chain												
	ABS, BV, CCS, CR, DNV, GL, KR, LR, NK, RINA, RMRS				API	ABS		DNV		ABS/DNV		ABS/DNV			ABS/DNV		
	Grade2		Grade3			C/EL/E	C/EL/E	SL	C/EL/E/SL	C/EL/E	SL	C/EL/E/SL	C/EL/E	SL	C/EL/E/SL	C/EL/E	SL
	PL	BL	PL	BL	RQ3												
	C=0.098	C=0.0137	C=0.0137	C=0.0196	C=0.014	C=0.0211	C=0.0148	C=0.0156	C=0.0223	C=0.0180	C=0.0174	C=0.0249	C=0.0216	C=0.0192	C=0.0274		
mm	KN	KN	KN	KN	KN	KN	KN	KN	KN	KN	KN	KN	KN	KN	KN	KN	KN
73	1990	2790	2790	3990	2847	4291	3010	3175	4535	3660	3545	5064	4392	3900	5572		
76	2150	3010	3010	4300	3066	4621	3242	3419	4884	3942	3818	5454	4731	4206	6001		
78	2260	3160	3160	4500	3216	4847	3400	3587	5123	4135	4004	5720	4962	4411	6295		
81	2410	3380	3380	4820	3446	5194	3643	3843	5490	4431	4291	6130	5317	4727	6745		
84	2580	3610	3610	5160	3683	5550	3893	4107	5866	4735	4585	6550	5682	5051	7208		
87	2750	3850	3850	5500	3925	5916	4149	4377	6252	5046	4887	6981	6056	5383	7682		
90	2920	4090	4090	5840	4173	6289	4412	4653	6647	5365	5196	7422	6439	5724	8167		
92	3040	4260	4260	6080	4242	6544	4590	4842	6916	5582	5405	7722	6699	5955	8497		
95	3230	4510	4510	6440	4599	6932	4862	5128	7326	5913	5726	8180	7096	6308	9001		
97	3340	4680	4680	6690	4774	7195	5047	5323	7604	6138	5943	8490	7365	6547	9343		
100	3530	4940	4940	7060	5040	7596	5328	5620	8028	6480	6275	8964	7776	6912	9864		
102	3660	5120	5120	7320	5220	7868	5519	5821	8315	6712	6500	9285	8054	7160	10217		
105	3850	5390	5390	7700	5495	8282	5809	6128	8753	7065	6842	9773	8478	7536	10754		
107	3980	5570	5570	7960	5681	8561	6005	6334	9048	7304	7072	10103	8764	7791	11118		
111	4250	5940	5940	8480	6058	9130	6401	6755	9650	7789	7543	10775	9347	8309	11856		
114	4440	6230	6230	8890	6346	9565	6709	7077	10109	8159	7901	11287	9791	8704	12420		
117	4650	6510	6510	9300	6639	10005	7018	7402	10574	8535	8265	11807	10242	9105	12993		
120	4850	6810	6810	9720	6953	10452	7331	7733	11047	8916	8634	12334	10700	9511	13573		
122	5000	7000	7000	9990	7135	10753	7542	7956	11365	9173	8883	12690	11008	9785	13964		
124	5140	7200	7200	10280	7336	11057	7755	8175	11688	9433	9134	13048	11319	10062	14358		
127	5350	7490	7490	10710	7641	11516	8078	8515	12172	9825	9514	13951	11790	10480	14955		
130	5570	7800	7800	11140	7950	11981	8404	8858	12663	10222	9898	14140	12266	10903	15559		
132	5720	8000	8000	11420	8157	12294	8623	9090	12994	10488	10157	14509	12586	11187	15965		
137	6080	8510	8510	12160	8682	13085	9178	9674	13829	11163	10809	15442	13395	11907	16992		
142	6450	9030	9030	12910	9214	13887	9740	10268	14677	11847	11472	16389	14217	12637	18034		
147	6840	9560	9560	13660	9753	14670	10310	10869	15536	12540	12144	17348	15049	13377	19089		
152	7220	10100	10100	14430	10299	15522	10887	11477	16405	13242	12823	18318	15890	14125	20157		
157	7600	10640	10640	15200	11126	16768	11762	12090	17282	13950	13508	19297	16740	14880	21234		
162	7990	11180	11180	15980	11405	17189	12057	12708	18166	14663	14199	20284	17596	15641	22320		

Testing Load of Anchor Chain and Accessories & Mooring Chain

Diameter of Chain	Anchor Chain				Offshore Mooring Chain												
	ABS, BV, CCS, CR, DNV, GL, KR, LR, NK, RINA, RMRS				API	ABS		DNV		ABS/DNV		ABS/DNV			ABS/DNV		
	Grade2		Grade3			C/EL/E	C/EL/E	SL	C/EL/E/SL	C/EL/E	SL	C/EL/E/SL	C/EL/E	SL	C/EL/E/SL	C/EL/E	SL
	PL	BL	PL	BL	RQ3												
	C=1422	C=1991	C=1991	C=2844	C=2030.5	C=3060.3	C=2147	C=2265.2	C=3236	C=2610	C=2527	C=3610	C=3125	C=2783.9	C=3977		
in	lbf	lbf	lbf	lbf	lbf	lbf	lbf	lbf	lbf	lbf	lbf	lbf	lbf	lbf	lbf	lbf	lbf
1/2	15300	21400	21400	30600													
9/16	19300	27000	27000	38600	-	-	-	-	-	-	-	-	-	-	-	-	-
5/8	23700	33200	33200	47500	-	-	-	-	-	-	-	-	-	-	-	-	-
11/16	28600	40100	40100	57300	-	-	-	-	-	-	-	-	-	-	-	-	-
3/4	34000	47600	47600	68000	-	-	-	-	-	-	-	-	-	-	-	-	-
13/16	39800	55700	55700	79500	-	-	-	-	-	-	-	-	-	-	-	-	-
7/8	46000	64400	64400	91800	-	-	-	-	-	-	-	-	-	-	-	-	-
15/16	52600	73700	73700	105000	-	-	-	-	-	-	-	-	-	-	-	-	-
1	59700	83600	83600	119500	-	-	-	-	-	-	-	-	-	-	-	-	-
1 1/16	67200	94100	94100	135000	-	-	-	-	-	-	-	-	-	-	-	-	-
1 1/8	75000	105000	105000	150000	-	-	-	-	-	-	-	-	-	-	-	-	-
1 3/16	83400	116500	1165000	167000	-	-	-	-	-	-	-	-	-	-	-	-	-
1 1/4	92200	129000	129000	184000	-	-	-	-	-	-	-	-	-	-	-	-	-
1 5/16	101500	142000	142000	203000	-	-	-	-	-	-	-	-	-	-	-	-	-
1 3/8	111000	155000	155000	222000	158187	238413	167263	176471	252101	203333	196867	281238	243454	216880	309829		
1 7/16	120500	169000	169000	241000	172361	259777	182251	192284	274691	221553	214507	306439	265269	236314	337592		
1 1/2	131000	183500	183500	262000	187095	281983	197829	208721	298172	240491	232843	332633	287944	256515	366449		
1 9/16	142000	198500	198500	284000	202381	305022	213993	225774	322534	260140	251868	359811	311471	277473	396390		
1 5/8	153000	214000	214000	306000	218215	328885	230735	243437	347767	280492	271573	387961	335838	299181	427401		
1 11/16	166500	229000	229000	327000	234589	353564	248048	261704	373863	301540	291951	417072	361039	321631	459472		
1 3/4	176000	247000	247000	352000	251498	379048	265927	280568	400811	323274	312994	447134	387062	344814	492591		
1 13/16	188500	264000	264000	377000	268935	405330	284366	300021	428601	345689	334696	478136	413899	368721	526745		
1 7/8	201000	281000	281000	402000	286896	432399	303357	320057	457225	368775	357048	510068	441541	393346	561923		
1 15/16	214000	299000	299000	427000	305373	460247	322894	340670	486671	392526	380043	542918	469978	418679	598112		
2	227000	318000	318000	454000	324361	488865	342971	361853	516932	416932	403674	576676	499201	444712	635302		
2 1/16	241000	337000	337000	482000	343853	518243	363582	383598	547997	441988	427932	611331	529200	471437	673481		
2 1/8	255000	357000	357000	510000	363844	548373	384719	405899	579856	467684	452811	646873	559966	498845	712635		
2 3/16	269000	377000	377000	538000	384327	579244	406378	428750	612500	494013	478303	683290	591491	526928	752755		
2 1/4	284000	396000	396000	570000	405297	610849	428551	452144	645920	520968	504400	720572	623764	555679	793827		
2 5/16	299000	418000	418000	538000	426747	643178	451232	476074	680105	548540	531096	758708	656776	585088	835840		
2 3/8	314000	440000	440000	628000	448672	676222	474414	500532	715046	576721	558381	797687	690519	615147	878782		
2 7/16	330000	462000	462000	660000	471064	709972	498092	525514	750733	605505	586250	837499	724982	645849	922641		
2 1/2	346000	4															

ANCHOR CHAIN

Testing Load of Anchor Chain and Accessories & Mooring Chain

Diameter of Chain	Anchor Chain				Offshore Mooring Chain											
	ABS,BV,CCS,CR,DNV,GL, KR,LR,NK,RINA,RMRS				API		ABS	DNV ABS	ABS/DNV	ABS/DNV			ABS/DNV			
					C/EL/E		C/EL/E	C/EL/E/SL	C/EL/E/SL	C/EL/E	SL	C/EL/E/SL	C/EL/E	SL	C/EL/E/SL	
	Grade2		Grade3		ORQ		RQ3	NVR3/RQ3	NVR3/RQ3	RQ3S/NVR3S			RQ4/NVR4			
	PL C=1422	BL C=1991	PL C=1991	BL C=2844	PL C=2030.5	BL C=3060.3	PL C=2147	PL C=2265.2	BL C=3236	PL C=2610	PL C=2527	BL C=3610	PL C=3125	PL C=2783.9	BL C=3977	
in	lbf	lbf	lbf	lbf	lbf	lbf	lbf	lbf	lbf	lbf	lbf	lbf	lbf	lbf	lbf	
2 15/16	467000	654000	654000	934000	666341	1004287	704573	743362	1061945	856514	829276	1184680	1025519	913582	1305116	
3	485000	679000	679000	970000	692677	1043979	732419	772742	1103917	890365	862051	1231501	1066051	949689	1356698	
3 1/16	504000	705000	705000	1008000	719421	1084286	760698	802577	1146538	924742	895334	1279049	1107210	986356	1409079	
3 1/8	523000	732000	732000	1046000	746566	1125199	789400	832860	1189799	959634	929117	1327310	1148987	1023573	1462247	
3 3/16	542000	759000	759000	1084000	774107	1166708	818522	8635584	1233692	995036	963393	1376275	1191374	1061333	1516190	
3 1/4	562000	787000	787000	1124000	802038	1208804	848055	894744	1278205	1030938	998153	1425933	1234361	1099628	1570897	
3 5/16	582000	814000	814000	1163000	830353	1251479	877995	926331	1323330	1067334	1033392	1476274	1277938	1138448	1626355	
3 3/8	602000	843000	843000	1204000	859045	1294723	908333	958340	1369057	1104215	1069100	1527285	1322096	1177787	1682552	
3 7/16	622000	871000	871000	1244000	888109	1338528	939065	990763	1415376	1141573	1105271	1578958	1366826	1217635	1739478	
3 1/2	643000	900000	900000	1285000	917539	1382883	970183	1023595	1462278	1179402	1141896	1631280	1412119	1257984	1797119	
3 9/16	664000	929000	929000	1327000	947328	1427780	1001681	1056827	1509752	1217693	1178969	1684242	1457965	1298826	1855465	
3 5/8	685000	958000	958000	1369000	977470	1473210	1033553	1090453	1557790	1256438	1216482	1737832	1504356	1340152	1914503	
3 3/4	728000	1019000	1019000	1455000	1038792	1565631	1098392	1158863	1655518	1335260	1292798	1846854	1598731	1424226	2034609	
3 7/8	772000	1080000	1080000	1543000	1101454	1660074	1164650	1228768	1755383	1415807	1370783	1958261	1695171	1510139	2157342	
3 15/16	794000	1111000	1111000	1587000	1133274	1708031	1198295	1264266	1806093	1456707	1410383	2014832	1744142	1553765	2219664	
4	816000	1143000	1143000	1632000	1165410	1756466	1232275	1300117	1857309	1498015	1450377	2071967	1793601	1597825	2282608	
4 1/8	862000	1207000	1207000	1724000	1230610	1854734	1301217	1372853	1961219	1581824	1531521	2187886	1893946	1687218	2410311	
4 1/4	908000	1272000	1272000	1817000	1297007	1954805	1371423	1446925	2067035	1667170	1614153	2305932	1996133	1778251	2540358	
4 3/8	956000	1338000	1338000	1911000	1364552	2056606	1442843	1522277	2174681	1753992	1698214	2426019	2100086	1870857	2672653	
4 1/2	1004000	1405000	1405000	2008000	1433196	2160004	1515426	1598856	2284079	1842227	1783643	2548061	2205732	1964972	2807102	
4 5/8	1053000	1474000	1474000	2105000	1502892	2265107	1589121	1676607	2395153	1931814	1870381	2671972	2312996	2060527	2943610	
4 3/4	1102000	1543000	1543000	2204000	1573591	2371662	1663876	1755478	2507825	2022690	1958367	2797667	2421803	2157458	3082083	
4 7/8	1153000	1613000	1613000	2305000	1645244	2479655	1739640	1835413	2622019	2114793	2047541	2925058	2532079	2255698	3222425	
5	1203000	1685000	1685000	2407000	1717804	2589014	1816363	1916360	2737657	2208061	2137843	3054061	2643751	2355180	3364543	
5 1/8	1255000	1757000	1757000	2509000	1791221	2699666	1893992	1998263	2854661	2302431	2229212	3184588	2756742	2455838	3508340	
5 1/4	-	-	-	-	1865448	2811539	1972478	2081070	2972957	2397842	2321589	3316555	2870979	2557806	3653723	
5 3/8	1359000	1903000	1903000	2718000	1940436	2924558	2051768	2164726	3092465	2494232	2414913	3449876	2986388	2660418	3800597	
5 1/2	-	-	-	-	2016137	3038652	2131813	2249176	3213109	2591537	2509125	3584463	3102894	2764207	3948867	
5 5/8	1466000	2052000	2052000	2935000	2092502	3153747	2212559	2334369	3334812	2689697	2604163	3720232	3220423	2868907	4098439	
5 3/4	1520000	2128000	2128000	3039000	2169484	3269771	2293958	2420248	3457497	2788649	2699968	3857097	3338900	2974452	4249217	
5 7/8	-	-	-	-	2247033	3386651	2375957	2506761	3581087	2888331	2796480	3994971	3458250	3080776	4401108	
6	1629000	2280000	2280000	3257000	2325102	3504313	2458504	2593854	3705505	2988680	2893638	4133768	3578401	3187811	4554015	
6 1/8	-	-	-	-	2403641	3622686	2541550	2681472	3830674	3089635	2991382	4273403	3699276	3295492	4707846	
6 1/4	1684000	2357000	2357000	3367000	2482604	3741695	2625043	2769561	3956516	3191133	3089653	4413790	3820801	3403753	4862504	
6 3/8	1795000	2512000	2512000	3589000	2651941	3861269	2708932	2858069	4082955	3293113	3188389	4554842	3942903	3512527	5017896	

ANCHOR CHAIN

Testing Load of Studless Chain

Diameter of Chain	Grade1		Grade2		Grade3		Approx.mass (27.5m)
	PL	BL	PL	BL	PL	BL	
mm	KN	KN	KN	KN	KN	KN	Kg
6	6.62	13.32	9.3	18.6	-	-	21.45
7	9.02	18.13	12.6	25.2	-	-	29.15
8	11.78	23.68	16.5	33	-	-	38.23
9	14.9	29.97	20.9	41.8	-	-	48.4
10	18.4	37	25.8	51.6	-	-	29.68
11	22.26	44.7	31.2	62.4	-	-	72.33
12.5	28.75	57.81	41.2	82.6	-	-	93.5
14	34.78	69.93	51	101.9	-	-	117.15
16	47.1	94.72	66.2	132.3	92.42	184.83	152.9
17.5	56.35	113.31	78.89	157.78	110.55	221.1	182.8
19	66.42	133.57	93.6	187.2	130.32	260.64	249.5
20.5	77.33	155.49	108.64	217.27	151.7	303.42	275.4
22	89.06	179.08	125.4	250.9	174.4	349.4	328.6
24	105.98	213.25	149.9	298.9	207.9	415.8	385
26	124.38	250.12	175.4	350.8	244	488	449.1
28	144.26	290.08	203.8	406.7	283	566	516.7
30	165.6	333	234.2	467.5	324.9	649.8	589.4
32	188.42	378.88	265.6	531.2	369.6	739.3	664.6
34	212.7	427.72	299.9	599.8	417.3	834.6	752.9
36	238.46	479.52	336.1	672.3	467.8	935.7	861.2
38	265.7	534.28	374.4	748.7	521.3	1042.5	957.5
40	294.4	592	414.5	829.1	577.6	1155.2	1056.2
42	324.58	652.68	457.7	915.3	636.8	1273.6	1166.5
44	356.22	716.32	502.7	999.6	698.9	1398	1270.4
46	389.34	782.92	548.8	1097.6	763.9	1527.8	1396.6
48	423.94	852.48	597.8	1195.6	831.7	1663.5	1520.6
50	460	926.09	648.8	1299.6	902.5	1805	1650

ANCHOR CHAIN

Arrangement of Anchor Chain

01a

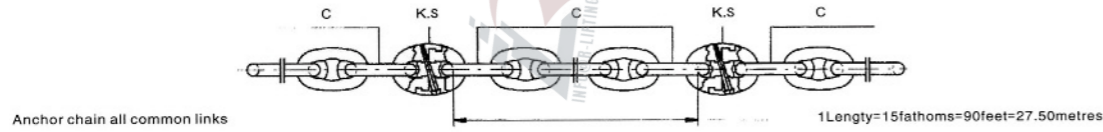

02a

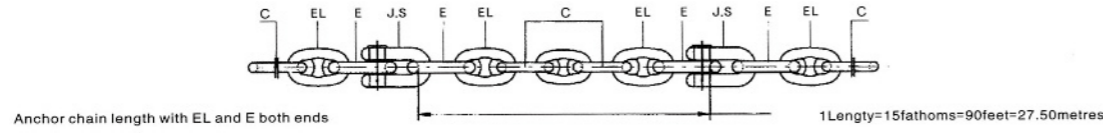

03a

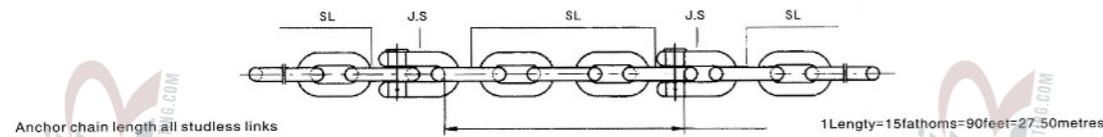

04a

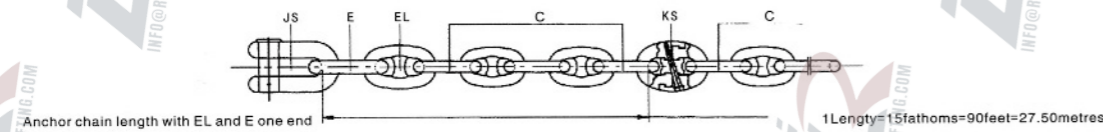

05sc

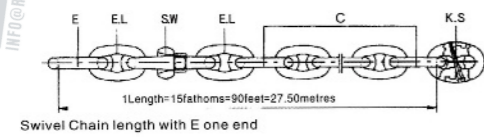

06sc

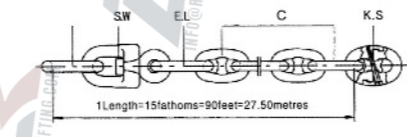

07sc

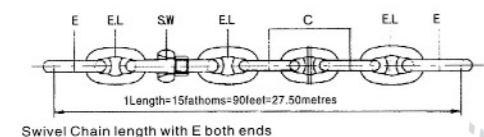

06sc

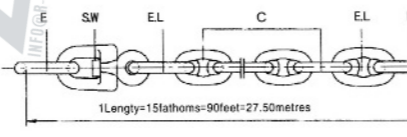

09sc

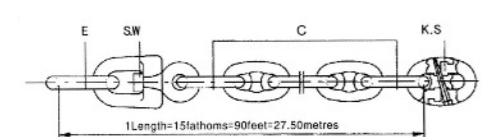

10sc

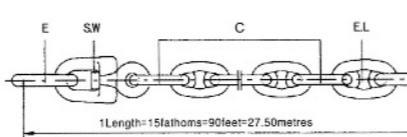

11sc

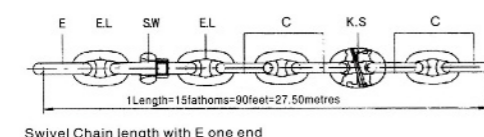

12sc

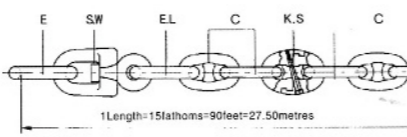

13sf

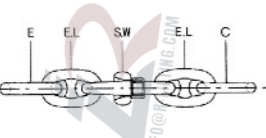

14sf

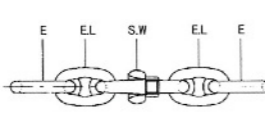

15sf



16sf

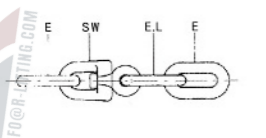

17sf

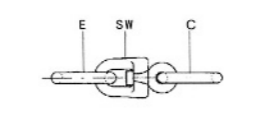

18sf

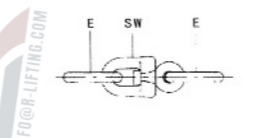

19ta

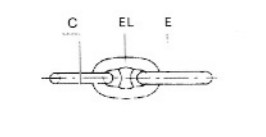

20ta

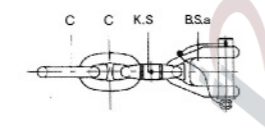

21ta

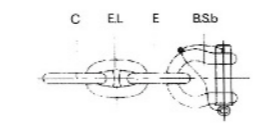

ANCHOR

GB545-96 Admiralty Anchor

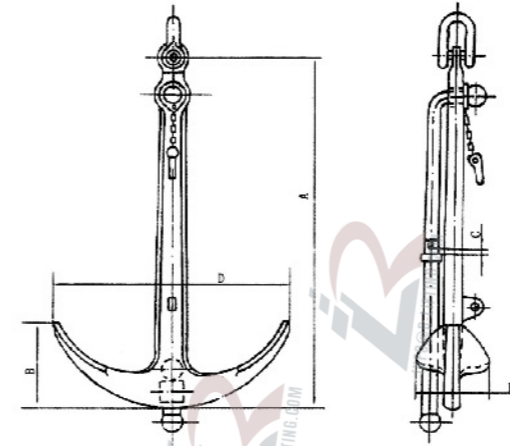

Weight (kg)	Size (mm)	A	B	C	D	E
50	960	230	42	635	185	
75	1105	266	45	710	210	
100	1215	293	49	780	230	
125	1310	316	52	840	245	
150	1395	336	55	900	265	
200	1535	370	61	990	290	
250	1650	398	65	1065	310	
300	1755	423	70	1105	330	
400	1930	465	77	1240	365	
500	2080	502	84	1335	390	
600	2210	533	89	1440	415	
700	2330	560	93	1500	440	
800	2435	587	97	1570	460	
900	2530	610	101	1630	475	
1000	2620	633	104	1685	495	
1250	2825	680	112	1810	535	
1500	3000	725	118	1955	565	
2000	3300	797	131	2140	625	
2500	3550	857	138	2270	672	
3000	3780	912	150	2415	715	
3500	3980	960	158	2540	750	
4000	4160	1000	155	2650	785	
5000	4480	1100	184	2830	800	
6000	4740	1113	190	3000	938	
7000	5025	1180	200	3165	960	
8000	4760	1280	210	3300	980	
9000	5450	1330	220	3440	990	
10000	5680	1340	230	3600	1085	

Danforth Anchor

Weight (kg)	Size (mm)	A	B	C	D	E	F
20	130	280	540	370	690	170	
25	135	300	580	400	740	185	
30	148	330	620	430	790	200	
40	160	360	680	470	860	220	
50	172	390	720	510	940	230	
60	186	408	755	535	985	240	
75	200	450	830	590	1080	260	
100	216	490	930	640	1180	290	
120	220	505	970	670	1230	300	
125	234	520	1000	690	1270	310	
150	242	550	1060	732	1348	330	
200	266	600	1150	810	1490	360	
250	294	650	1240	870	1600	390	
276	296	660	1250	885	1620	400	
300	312	690	1320	925	1700	420	
400	342	750	1460	1010	1810	460	
500	368	800	1570	1100	2020	490	
750	414	910	1800	1260	2300	560	
1000	450	980	1980	1380	2540	620	
1250	484	1070	2100	1490	2740	670	
1500	512	1120	2220	1580	2910	700	
2000	560	1130	2440	1730	2850	770	
2500	650	1217	2628	1864	3070	830	
4000	700	1420	3070	2170	3590	970	
5000	735	1482	3200	2270	3840	1020	
6000	800	1620	3500	2480	4100	1100	
7000	840	1696	3680	2590	4180	1150	
8500	864	1740	3930	2590	4390	1180	
10000	940	2000	4030	2590	4640	1280	
16000	1105	2240	4850	3435	5680	1520	
18000	1150	2200	5000	3570	5000	1580	

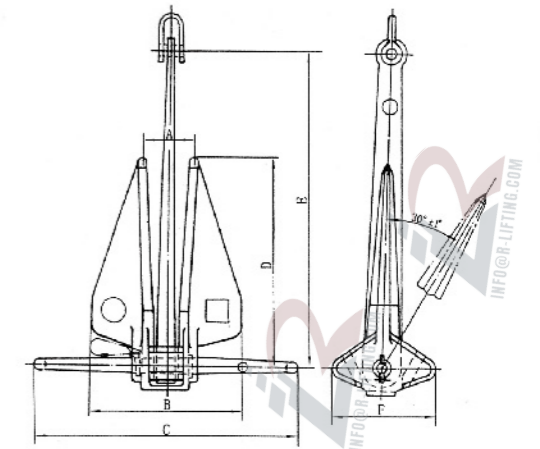

ANCHOR

HHP(HY-14)Stockless Anchor

Weight (kg)	Size (mm)					
	A	B	C	D	E	F
56	612	555	170	376	113	298
100	745	675	200	458	135	364
135	745	675	205	458	135	364
180	909	822	252	558	166	442
225	1010	915	277	623	185	495
250	1010	915	280	623	185	495
270	1040	940	288	638	190	508
300	1075	975	298	660	200	525
315	1075	975	300	660	200	525
340	1120	1015	310	690	205	548
360	1120	1015	313	690	205	548
428	1213	1098	336	745	222	590
495	1255	1135	348	770	230	610
590	1350	1220	375	829	246	658
675	1412	1278	390	868	257	690
765	1470	1335	408	906	269	718
910	1560	1410	430	957	284	760
970	1592	1445	440	978	292	775
1080	1650	1495	455	1014	302	805
1200	1710	1545	470	1050	315	835
1305	1760	1595	485	1082	323	858
1361	1782	1615	495	1096	326	870
1440	1818	1645	505	1118	332	885
1575	1875	1695	518	1152	343	915
1710	1925	1745	532	1184	352	940
1845	1975	1785	546	1215	362	965
1980	2020	1830	560	1242	370	985
2100	2065	1865	570	1268	377	1005
2295	2130	1920	588	1310	385	1035
2475	2175	1970	602	1340	395	1062
2655	2225	2018	615	1368	408	1085
2794	2265	2055	625	1393	415	1105
3040	2320	2100	640	1424	426	1130
3550	2455	2225	680	1508	450	1198
3670	2480	2248	688	1525	455	1210
3940	2540	2300	705	1562	465	1240
4500	2655	2405	735	1632	485	1295
4840	2720	2465	755	1670	500	1330
5175	2785	2520	770	1710	510	1358
5610	2858	2590	790	1758	523	1396
6000	2922	2646	810	1796	535	1426
6450	2995	2712	830	1840	548	1462
6900	3062	2775	848	1884	560	1496
7350	3126	2832	866	1923	572	1526
7800	3190	2890	884	1962	584	1558
8300	3256	2950	902	2002	596	1590
8700	3308	2996	916	2034	605	1614
9300	3382	3064	936	2080	619	1652
9675	3425	3104	948	2108	627	1674
9900	3452	3128	956	2124	632	1686
10500	3523	3192	976	2166	645	1720
11100	3589	3252	994	2207	657	1752
11700	3650	3308	1010	2245	668	1782
12300	3712	3364	1028	2283	680	1812
12900	3772	3418	1044	2320	690	1842
13500	3830	3470	1060	2355	700	1870
14100	3885	3520	1076	2389	710	1896
14700	3940	3570	1090	2423	721	1924
15400	4002	3626	1108	2461	732	1954
16100	4062	3680	1125	2498	744	1982
16900	4128	3740	1144	2538	755	2016
17800	4200	3806	1162	2583	769	2050
18800	4277	3875	1185	2630	783	2088
20000	4366	3956	1210	2685	800	2132
25000	5046	4577	1375	3135	846	2438

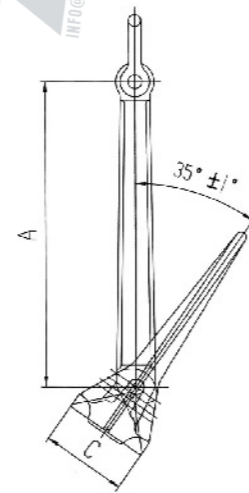
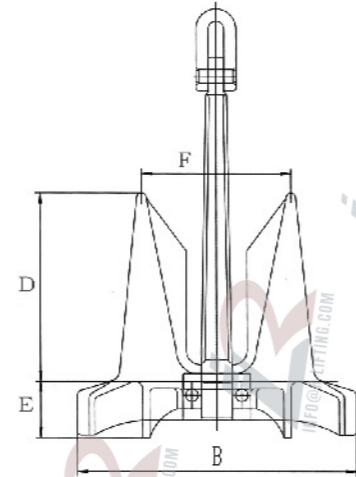

Hall Anchor

Weight (kg)	Size (mm)			h	h1	L	L1	B1	B	H1	I	J
	A	B	C									
100	760	760	590	410	90	584	410	228	270	115	85	24
150	866	866	665	470	103	570	470	260	308	130	98	28
180	919	919	718	500	109	710	500	276	327	145	110	32
240	1019	1019	788	552	120	790	552	305	361	160	122	36
300	1095	1095	850	595	130	844	595	328	388	175	136	40
360	1160	1160	898	630	138	898	630	347	412	175	136	40
420	1160	1160	946	660	145	946	660	366	434	192	151	45
480	1222	1222	986	690	152	988	690	384	454	215	163	48
570	1282	1282	1042	732	161	1042	732	407	481	215	163	48
660	1356	1356	1093	769	169	1096	769	426	506	235	174	50
780	1506	1506	1159	813	178	1160	813	452	535	235	174	50
1020	1645	1645	1268	855	188	1220	855	472	560	255	200	60
1290	1778	1778	1387	891	195	1268	891	492	584	280	215	62
1440	1844	1844	1448	965	203	1379	965	532	630	280	215	62
1740	1966	1966	1571	1068	234	1517	1068	589	698	310	236	68
1920	2031	2031	1602	1104	241	1568	1104	609	722	310	236	68
2280	2150	2150	1716	1165	255	1675	1165	645	763	340	256	74
2460	2207	2207	1785	1194	262	1700	1194	662	784	340	256	74
2850	2318	2318	1890	1253	275	1787	1253	695	822	380	279	82
3060	2374	2374	1935	1283	282	1832	1283	712	841	380	279	82
3540	2490	2490	2032	1349	295	1926	1349	749	883	385	284	82
4050	2610	2610	2125	1406	309	2008	1406	763	924	410	305	90
4590	2712	2712	2216	1465	322	2093	1465	813	962	415	335	100
4890	2769	2769	2263	1498	329	2135	1498	830	984	415	335	100
6000	2965	2965	2422	1605	352	2284	1605	889	1054	450	343	100
6900	3100	3100	2538	1681	369	2393	1681	932	1105	480	370	110
7800	3235	3235	2644	1752	385	2493	1752	971	1152	500	377	110
8700	3355	3355	2742	1816	399	2585	1816	1007	1195	540	391	117
9900	3502	3502	2863	1896	417	2699	1896	1052	1248	580	418	124
11100	3638	3638	2975	1970	433	2803	1970	1093	1297	600	437	130
15400	4056	4056	3318	2199	438	3126	2199	1220	1446	680	498	150

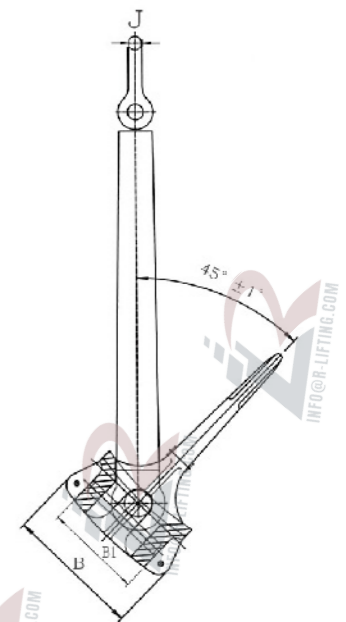
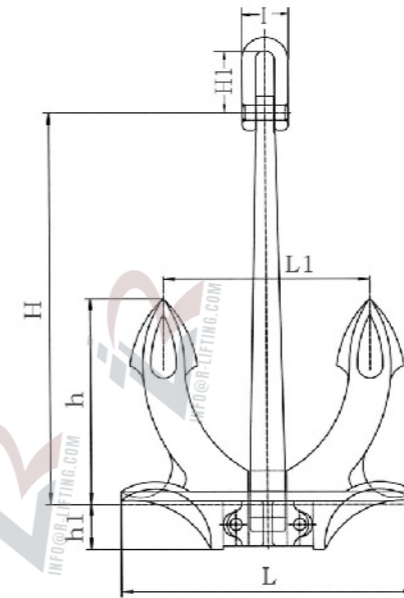

ANCHOR

Baldt Stockless Anchor

mm

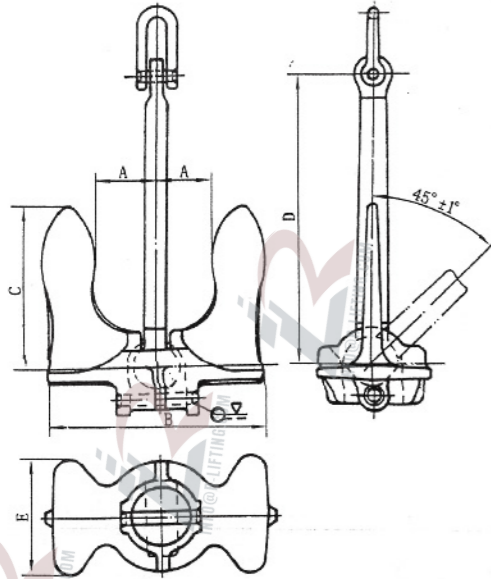

Weight (kg)	Size (mm)	A	B	C	D	E
50	82	312	236	420	165	
75	95	358	270	482	190	
100	102	360	305	505	208	
150	120	450	340	606	237	
200	128	460	366	604	249	
250	145	510	410	680	278	
300	155	560	442	730	300	
400	170	604	482	800	328	
500	195	710	530	900	360	
625	195	725	545	900	380	
750	205	770	584	965	415	
1000	235	854	640	1068	456	
1200	250	900	710	1170	470	
1500	265	1000	748	1232	508	
1720	298	1054	844	1320	533	
2000	320	1157	864	1460	625	
2200	320	1157	868	1473	591	
2500	320	1157	868	1473	591	
3000	326	1210	912	1504	620	
3500	326	1210	997	1626	699	
4000	350	1300	1054	1740	716	
5000	375	1400	1130	1804	768	
6000	456	1600	1194	2016	870	
7000	456	1660	1225	2083	870	
8000	463	1683	1241	2375	870	
10000	490	1810	1470	2438	1000	
11000	500	1900	1413	2408	1016	
11500	500	1900	1413	2408	1016	
12500	525	1920	1435	2424	1016	
15200	600	2150	1600	2616	1090	
17200	600	2215	1670	2795	1200	
20000	676	2490	1866	3080	1268	
22000	676	2490	1866	3080	1295	
25000	711	2616	1969	3048	1365	
30000	759	2794	2096	3251	1454	
35000	800	2946	2210	3429	1524	

Single Fluke Anchor

mm

Weight (kg)	Size (mm)	A	B	C	D	E	F
75	1310	1100	360	455	465	115	
100	1445	1200	400	500	510	130	
150	1650	1380	455	575	585	145	
200	1820	1520	505	630	645	160	
300	2080	1740	575	725	735	185	
400	2290	1915	635	800	810	205	
500	2470	2065	680	855	875	220	
600	2620	2190	725	910	930	230	
800	2890	2415	800	1000	1020	255	
1000	3110	2600	860	1080	1100	275	
1250	3350	2800	925	1165	1185	295	
1500	3560	2980	985	1235	1260	315	
1750	3750	3135	1035	1300	1325	330	
2000	3920	3275	1085	1360	1385	345	
3000	4485	3750	1240	1555	1585	395	
4000	4940	4125	1360	1710	1745	435	
5000	5320	4440	1472	1845	1880	468	
6000	5650	4720	1560	1960	1995	495	
7000	5950	4970	1645	2065	2100	525	
8000	6220	5200	1720	2155	2200	545	

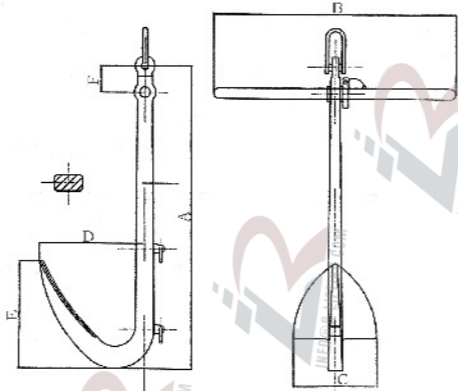

ANCHOR

Pool Anchor(Type N)

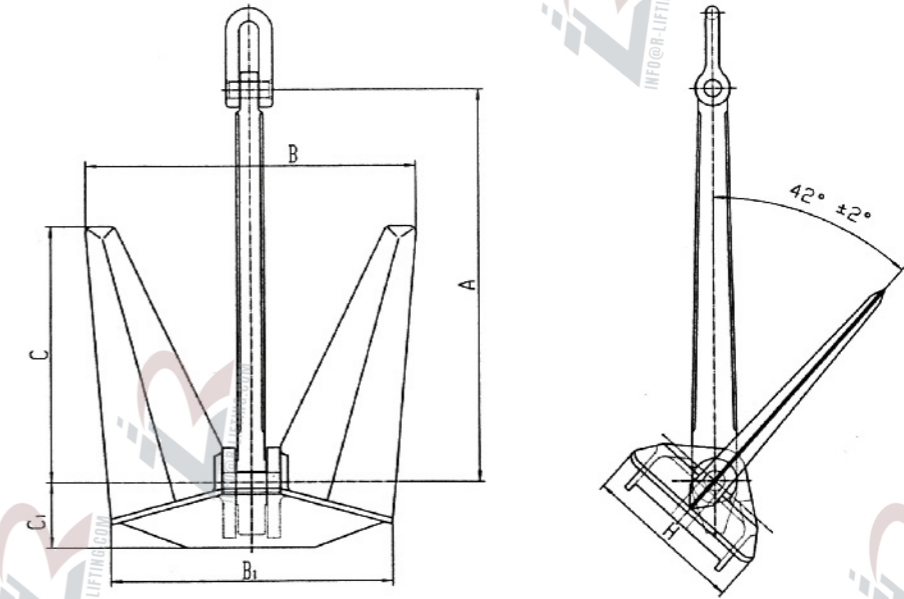

kg Nominal Weight	A	B	B1	C	C1	H
20	455	385	325	300	75	185
30	521	441	372	344	86	212
40	570	480	410	370	95	235
50	614	517	442	398	102	253
60	655	555	470	425	110	270
70	689	583	492	450	115	282
80	720	610	515	470	120	295
100	775	655	555	505	130	320
120	825	700	595	540	135	340
160	905	765	650	590	150	370
200	975	825	700	640	160	400
240	1040	880	745	680	175	425
280	1090	925	780	715	180	450
320	1140	965	820	748	190	470
360	1190	1005	855	780	195	490
400	1230	1040	885	805	205	505
440	1270	1075	910	830	210	520
480	1305	1105	940	855	215	535
520	1340	1135	960	875	220	550
560	1375	1165	985	900	230	565
600	1410	1195	1010	920	235	580
640	1440	1220	1035	940	240	590
720	1495	1265	1075	975	248	610
760	1528	1290	1096	1000	250	615
800	1550	1310	1115	1015	255	635
900	1615	1365	1160	1055	270	665

kg Nominal Weight	A	B	B1	C	C1	H
1000	1670	1410	1200	1090	275	670
1250	1800	1525	1290	1175	300	740
1500	1910	1615	1370	1250	315	765
1750	2015	1705	1445	1320	335	775
2000	2080	1770	1500	1370	345	780
2250	2105	1850	1570	1430	350	812
2500	2240	1910	1620	1510	350	839
2900	2320	1980	1650	1510	350	855
3200	2390	2040	1700	1560	360	885
3500	2470	2110	1760	1610	380	910
3900	2580	2190	1820	1670	390	945
4300	2650	2260	1880	1730	400	980
4750	2730	2330	1950	1780	420	1010
5250	2820	2410	2010	1840	430	1040
5800	2910	2490	2080	1900	450	1080
6400	3010	2570	2150	1980	460	1110
7050	3110	2660	2220	2030	470	1150
7800	3250	2750	2290	2100	480	1190
8800	3320	2840	2370	2160	510	1225
9500	3430	2930	2450	2240	520	1270
10600	3550	3030	2530	2310	540	1310
11800	3670	3130	2610	2390	560	1355
12800	3790	3240	2700	2470	580	1400
14200	3920	3350	2790	2550	600	1450
15700	4030	3450	2880	2630	610	1490
17200	4150	3550	2960	2710	630	1540